

Service Manual

Tektronix

TDS 684A & TDS 744 Digitizing Oscilloscope

070-8992-02

Warning

The servicing instructions are for use by qualified personnel only. To avoid personal injury, do not perform any servicing unless you are qualified to do so. Refer to the Safety Summary prior to performing service.

**Please check for change information
at the rear of this manual.**

Third Edition: November 1994

Copyright © Tektronix, Inc. 1994. All rights reserved.

Tektronix products are covered by U.S. and foreign patents, issued and pending. Information in this publication supercedes that in all previously published material. Specifications and price change privileges reserved.

Printed in the U.S.A.

Tektronix, Inc., P.O. Box 1000, Wilsonville, OR 97070-1000

TEKTRONIX and TEK are registered trademarks of Tektronix, Inc.

WARRANTY

Tektronix warrants that this product will be free from defects in materials and workmanship for a period of three (3) years from the date of shipment. If any such product proves defective during this warranty period, Tektronix, at its option, either will repair the defective product without charge for parts and labor, or will provide a replacement in exchange for the defective product.

In order to obtain service under this warranty, Customer must notify Tektronix of the defect before the expiration of the warranty period and make suitable arrangements for the performance of service. Customer shall be responsible for packaging and shipping the defective product to the service center designated by Tektronix, with shipping charges prepaid. Tektronix shall pay for the return of the product to Customer if the shipment is to a location within the country in which the Tektronix service center is located. Customer shall be responsible for paying all shipping charges, duties, taxes, and any other charges for products returned to any other locations.

This warranty shall not apply to any defect, failure or damage caused by improper use or improper or inadequate maintenance and care. Tektronix shall not be obligated to furnish service under this warranty a) to repair damage resulting from attempts by personnel other than Tektronix representatives to install, repair or service the product; b) to repair damage resulting from improper use or connection to incompatible equipment; or c) to service a product that has been modified or integrated with other products when the effect of such modification or integration increases the time or difficulty of servicing the product.

THIS WARRANTY IS GIVEN BY TEKTRONIX WITH RESPECT TO THIS PRODUCT IN LIEU OF ANY OTHER WARRANTIES, EXPRESSED OR IMPLIED. TEKTRONIX AND ITS VENDORS DISCLAIM ANY IMPLIED WARRANTIES OF MERCHANTABILITY OR FITNESS FOR A PARTICULAR PURPOSE. TEKTRONIX' RESPONSIBILITY TO REPAIR OR REPLACE DEFECTIVE PRODUCTS IS THE SOLE AND EXCLUSIVE REMEDY PROVIDED TO THE CUSTOMER FOR BREACH OF THIS WARRANTY. TEKTRONIX AND ITS VENDORS WILL NOT BE LIABLE FOR ANY INDIRECT, SPECIAL, INCIDENTAL, OR CONSEQUENTIAL DAMAGES IRRESPECTIVE OF WHETHER TEKTRONIX OR THE VENDOR HAS ADVANCE NOTICE OF THE POSSIBILITY OF SUCH DAMAGES.

Table of Contents

General Safety Summary	ix
Service Safety Summary	xiii
Preface	xv
Introduction	xix

Specifications

Product Description	1-1
User Interface	1-2
Signal Acquisition System	1-2
Horizontal System	1-3
Trigger System	1-4
Acquisition Control	1-4
On-Board User Assistance	1-5
Measurement Assistance	1-5
Storage	1-6
I/O	1-6
Display	1-7
Nominal Traits	1-9
Warranted Characteristics	1-15
Typical Characteristics	1-21

Operational Information

Installation	2-1
Supplying Operating Power	2-1
Operating Environment	2-3
Applying and Interrupting Power	2-3
Repackaging Instructions	2-4
Installed Options	2-5
Operating Instructions	2-7
Screen Layout	2-7
Basic Procedures	2-7

Theory of Operation

Logic Conventions	3-1
Module Overview	3-1

Performance Verification

Performance Verification Procedures	4-1
Conventions	4-2
Brief Procedures	4-5
Self Tests	4-5
Functional Tests	4-7

Table of Contents

Performance Tests	4-15
Prerequisites	4-15
Equipment Required	4-16
TDS 684A Test Record	4-19
TDS 744 Test Record	4-23
Signal Acquisition System Checks	4-27
Time Base System Checks	4-41
Trigger System Checks	4-43
Output Signal Checks	4-56
Option 05 Video Trigger Checks	4-64
 Adjustment Procedures	
Requirements for Performance	5-1
Usage	5-2
Equipment Required	5-5
Adjustment Instructions	5-7
Probe Adjustment for the P6139A Probe	5-10
Display Assembly Adjustment	5-20
 Maintenance	
Related Maintenance Procedures	6-1
Preparation	6-2
Inspection and Cleaning	6-4
Removal and Installation Procedures	6-9
Preparation — Please Read	6-9
Access Procedure	6-15
Procedures for External Modules	6-16
Procedures for Outer-Chassis Modules	6-29
Procedures for Inner-Chassis Modules	6-46
Disassembly for Cleaning	6-53
Troubleshooting	6-57
Diagnostics	6-57
Firmware Updates	6-58
 Options	
Electrical Parts List	
Diagrams	
Mechanical Parts List	

List of Figures

Figure 2-1: Map of Display Functions	2-8
Figure 4-1: Map of Display Functions	4-3
Figure 4-2: Verifying Adjustments and Signal-Path Compensation .	4-6
Figure 4-3: Universal Test Hookup for Functional Tests	4-8
Figure 4-4: Measurement of DC Offset Accuracy at Zero Setting ...	4-29
Figure 4-5: Initial Test Hookup	4-30
Figure 4-6: Measurement of DC Accuracy at Maximum Offset and Position	4-32
Figure 4-7: Initial Test Hookup	4-34
Figure 4-8: Measurement of Analog Bandwidth	4-36
Figure 4-9: Initial Test Hookup	4-38
Figure 4-10: Measurement of Channel Delay	4-40
Figure 4-11: Initial Test Hookup	4-41
Figure 4-12: Measurement of Accuracy — Long-Term and Delay Time	4-43
Figure 4-13: Initial Test Hookup	4-44
Figure 4-14: Measurement of Time Accuracy for Pulse and Glitch Triggering	4-46
Figure 4-15: Initial Test Hookup	4-47
Figure 4-16: Measurement of Trigger-Level Accuracy	4-49
Figure 4-17: Initial Test Hookup	4-52
Figure 4-18: Measurement of Trigger Sensitivity — 50 MHz Results Shown on a TDS 684A Screen	4-53
Figure 4-19: Initial Test Hookup	4-56
Figure 4-20: Measurement of Main Trigger Out Limits	4-58
Figure 4-21: Initial Test Hookup	4-60
Figure 4-22: Measurement of Probe Compensator Frequency	4-61
Figure 4-23: Subsequent Test Hookup	4-62
Figure 4-24: Measurement of Probe Compensator Amplitude	4-63
Figure 4-25: Jitter Test Hookup	4-65
Figure 4-26: Jitter Test Displayed Waveform	4-66
Figure 4-27: Jitter Test When Completed – TDS 684A Shown	4-67
Figure 4-28: Triggered Signal Range Test – 300 mV	4-69
Figure 4-29: Triggered Signal Range Test – 75 mV	4-70
Figure 4-30: 60 Hz Rejection Test Hookup	4-71

Figure 4-31: 60 Hz Rejection Test Setup Signal	4-71
Figure 4-32: Subsequent 60 Hz Rejection Test Hookup	4-72
Figure 4-33: 60 Hz Rejection Test Result – TDS 684A Shown	4-73
Figure 4-34: Line Count Accuracy Test Hookup	4-74
Figure 4-35: Line Count Accuracy Test Setup Waveform – TDS 684A Shown	4-75
Figure 4-36: Line Count Accuracy Correct Result Waveform	4-76
Figure 4-37: PG502 Setup for Sync Duty Cycle Test	4-78
Figure 4-38: Sync Duty Cycle Test: One-Div Neg Pulse Waveform ..	4-79
Figure 4-39: Sync Duty Cycle Test: Critically Adjusted Pulse	4-80
Figure 5-1: Accessing the Protection Switch	5-9
Figure 5-2: Hookup for Probe Compensation	5-10
Figure 5-3: Performing Probe Compensation	5-11
Figure 5-4: Proper and Improper Probe Compensation	5-12
Figure 5-5: Exposing the Inner Probe Tip	5-13
Figure 5-6: Initial Test Hookup	5-13
Figure 5-7: Exposing the Probe Body	5-16
Figure 5-8: Initial Test Hookup	5-16
Figure 5-9: Locations of P6139A Probe Adjustments	5-18
Figure 5-10: Adjustments versus Front-Corner Response	5-19
Figure 5-11: Five and Ten Percent Luminance Patches	5-21
Figure 6-1: External Modules	6-12
Figure 6-2: Outer-Chassis Modules	6-13
Figure 6-3: Inner-Chassis Modules	6-14
Figure 6-4: Knob Removal	6-17
Figure 6-5: Line Fuse and Line Cord Removal	6-18
Figure 6-6: Rear Cover and Cabinet Removal	6-21
Figure 6-7: Front Cover, Trim Ring, Menu Buttons, and Attenuator Panel Removal (Front Cover not Shown)	6-22
Figure 6-8: A12 Front-Panel Assembly Removal	6-24
Figure 6-9: Disassembly of Front-Panel Assembly	6-25
Figure 6-10: Cabinet Modules Removal	6-28
Figure 6-11: A14 D1 Bus and Analog-Power and Digital-Power Cables Removal	6-30
Figure 6-12: Remove Circuit Board Assembly From Oscilloscope ..	6-31
Figure 6-13: Remove Circuit Board From Assembly	6-32
Figure 6-14: Circuit Board Installed	6-34
Figure 6-15: Circuit Board Removal	6-35

Figure 6-16: A11 Processor/Display Removal	6-37
Figure 6-17: Board Bracket Removal	6-38
Figure 6-18: A10 Acquisition Board Removal	6-41
Figure 6-19: Floppy Disk Removal	6-43
Figure 6-20: Rear Chassis Removal	6-45
Figure 6-21: A16 Low Voltage Power Supply Removal	6-47
Figure 6-22: Display Assembly Removal	6-49
Figure 6-23: Display Driver Board Removal	6-50
Figure 6-24: Front Subpanel Removal	6-52
Figure 6-25: Accessing the Protection Switch	6-58
Figure 6-26: Primary Troubleshooting Procedure	6-59
Figure 6-27: Module Isolation Troubleshooting Procedure	6-61
Figure 6-28: A16 Low Voltage Power Supply Module Isolation Troubleshooting Procedure	6-62
Figure 6-29: Power Supply Voltage Measurement Locations	6-63
Figure 6-30: Color Display Troubleshooting Procedure	6-64
Figure 6-31: Horizontal and Vertical Sync Signals – Color Display .	6-65
Figure 6-32: A Video Signal with White, Black, and Blanking Levels – Color Display	6-65
Figure 6-33: Processor/Acquisition Troubleshooting Procedure	6-66
Figure 6-34: Processor/Front Panel Troubleshooting Procedure	6-67
Figure 6-35: Attenuator/Acquisition Troubleshooting Procedure ...	6-68
Figure 6-36: A11 DRAM Processor/Display Module (View of Right Side)	6-70
Figure 6-37: A11 DRAM Processor/Display Module (View of Upper Left Corner)	6-71
Figure 6-38: A11 DRAM Processor/Display Module (View of Lower Left Corner)	6-71
Figure 6-39: A10 Acquisition Module (View of Lower Right Corner)	6-72
Figure 9-1: Interconnections	9-2
Figure 9-2: Block Diagram	9-4
Figure 10-1: External Modules	10-6
Figure 10-2: Outer-Chassis Modules	10-8
Figure 10-3: Inner-Chassis Modules	10-9
Figure 10-4: Cables, Bottom View	10-10
Figure 10-5: Cables, Top View	10-12
Figure 10-6: Floppy Disk	10-14
Figure 10-7: Accessories	10-15

Table of Contents

List of Tables

Table 1-1: Key Features of the TDS 684A and 744 Oscilloscopes . . .	1-1
Table 1-2: Record Length vs. Divisions per Record, Samples per Division and Sec/Div Sequence	1-3
Table 1-3: Nominal Traits — Signal Acquisition System	1-9
Table 1-4: Nominal Traits — Time Base System	1-10
Table 1-5: Nominal Traits — Triggering System	1-10
Table 1-6: Nominal Traits — Display System	1-11
Table 1-7: Nominal Traits — GPIB Interface, Output Ports, and Power Fuse	1-12
Table 1-8: Nominal Traits — Data Handling and Reliability	1-12
Table 1-9: Nominal Traits — Mechanical	1-13
Table 1-10: Warranted Characteristics — Signal Acquisition System	1-16
Table 1-11: Warranted Characteristics — Time Base System	1-17
Table 1-12: Warranted Characteristics — Triggering System	1-17
Table 1-13: Warranted Characteristics — Output Ports, Probe Compensator, and Power Requirements	1-18
Table 1-14: Warranted Characteristics — Environmental	1-19
Table 1-15: Typical Characteristics — Signal Acquisition System . .	1-21
Table 1-16: Typical Characteristics — Triggering System	1-23
Table 2-1: Power-Cord Conductor Identification	2-2
Table 2-2: Power Cord Identification	2-2
Table 2-3: Effects of Corrupted Data	2-4
Table 4-1: Test Equipment	4-16
Table 4-2: DC Offset Accuracy (Zero Setting)	4-28
Table 4-3: DC Accuracy	4-31
Table 4-4: Analog Bandwidth	4-35
Table 5-1: Calibration Tests	5-3
Table 5-2: Adjustments Required for Module Replaced	5-4
Table 5-3: Adjustments and Dependencies	5-4
Table 5-4: Test Equipment, Fixtures, and Supplies	5-5
Table 5-5: GPIB Board Configuration	5-7
Table 6-1: Relative Susceptibility to Static-Discharge Damage	6-3

Table of Contents

Table 6-2: External Inspection Check List	6-5
Table 6-3: Internal Inspection Check List	6-6
Table 6-4: Tools Required for Module Removal	6-11
Table 6-5: Normal Supply Voltages (Measured on J26 and J27 on the A11 DRAM Processor/Display Module)	6-63
Table 6-6: No-Load Supply Voltages (Measured on J5 and J6 on the A17 Main LV Power Supply Module)	6-63
Table 7-1: Options	7-1
Table 7-2: Standard Accessories	7-3
Table 7-3: Optional Accessories	7-4
Table 7-4: Accessory Software	7-5

General Safety Summary

Review the following safety precautions to avoid injury and prevent damage to this product or any products connected to it.

Only qualified personnel should perform service procedures.

Injury Precautions

- | | |
|---|--|
| Use Proper Power Cord | To avoid fire hazard, use only the power cord specified for this product. |
| Avoid Electric Overload | To avoid electric shock or fire hazard, do not apply a voltage to a terminal that is outside the range specified for that terminal. |
| Ground the Product | This product is grounded through the grounding conductor of the power cord. To avoid electric shock, the grounding conductor must be connected to earth ground. Before making connections to the input or output terminals of the product, ensure that the product is properly grounded. |
| Do Not Operate Without Covers | To avoid electric shock or fire hazard, do not operate this product with covers or panels removed. |
| Use Proper Fuse | To avoid fire hazard, use only the fuse type and rating specified for this product. |
| Do Not Operate in Wet/Damp Conditions | To avoid electric shock, do not operate this product in wet or damp conditions. |
| Do Not Operate in Explosive Atmosphere | To avoid injury or fire hazard, do not operate this product in an explosive atmosphere. |
| Keep Probe Surface Clean | To avoid electric shock and erroneous readings, keep probe surface clean. |

Product Damage Precautions

- | | |
|--------------------------------|---|
| Use Proper Power Source | Do not operate this product from a power source that applies more than the voltage specified. |
|--------------------------------|---|

General Safety Summary

- Use Proper Voltage Setting** Before applying power, ensure that the line selector is in the proper position for the power source being used.
- Provide Proper Ventilation** To prevent product overheating, provide proper ventilation.
- Do Not Operate With Suspected Failures** If you suspect there is damage to this product, have it inspected by qualified service personnel.
- Do Not Immerse in Liquids** Clean the probe using only a damp cloth. Refer to cleaning instructions.

Safety Terms and Symbols

Terms in This Manual These terms may appear in this manual:



WARNING. *Warning statements identify conditions or practices that could result in injury or loss of life.*



CAUTION. *Caution statements identify conditions or practices that could result in damage to this product or other property.*

Terms on the Product These terms may appear on the product:

DANGER indicates an injury hazard immediately accessible as you read the marking.

WARNING indicates an injury hazard not immediately accessible as you read the marking.

CAUTION indicates a hazard to property including the product.

Symbols on the Product

The following symbols may appear on the product:



DANGER
High Voltage



Protective Ground
(Earth) Terminal



ATTENTION
Refer to
Manual



Double
Insulated

Certifications and Compliances

**CSA Certified Power
Cords**

CSA Certification includes the products and power cords appropriate for use in the North America power network. All other power cords supplied are approved for the country of use.

General Safety Summary

Service Safety Summary

Only qualified personnel should perform service procedures. Read this *Service Safety Summary* and the *General Safety Summary* before performing any service procedures.

Do Not Service Alone

Do not perform internal service or adjustments of this product unless another person capable of rendering first aid and resuscitation is present.

Disconnect Power

To avoid electric shock, disconnect the main power by means of the power cord or, if provided, the power switch.

Use Caution When Servicing the CRT

To avoid electric shock or injury, use extreme caution when handling the CRT. Only qualified personnel familiar with CRT servicing procedures and precautions should remove or install the CRT.

CRTs retain hazardous voltages for long periods of time after power is turned off. Before attempting any servicing, discharge the CRT by shorting the anode to chassis ground. When discharging the CRT, connect the discharge path to ground and then the anode. Rough handling may cause the CRT to implode. Do not nick or scratch the glass or subject it to undue pressure when removing or installing it. When handling the CRT, wear safety goggles and heavy gloves for protection.

Use Care When Servicing With Power On

Dangerous voltages or currents may exist in this product. Disconnect power, remove battery (if applicable), and disconnect test leads before removing protective panels, soldering, or replacing components.

To avoid electric shock, do not touch exposed connections.

X-Radiation

To avoid x-radiation exposure, do not modify or otherwise alter the high-voltage circuitry or the CRT enclosure. X-ray emissions generated within this product have been sufficiently shielded.

Service Safety Summary

Preface

This preface contains information needed to properly use this manual to service the TDS 684A and 744 Digitizing Oscilloscopes, as well as general information critical to safe and effective servicing of this oscilloscope.

Manual Structure

This manual is divided into sections, such as *Specification and Theory of Operation*. Further, it is divided into subsections, such as *Product Description and Removal and Installation Procedures*.

Sections containing procedures also contain introductions to those procedures. Be sure to read these introductions because they provide information needed to do the service correctly and efficiently. The following is a brief description of each manual section.

- *Specification* contains a product description of the TDS 684A and 744 Digitizing Oscilloscopes and tables of the characteristics and descriptions that apply to it.
- *Operating Information* is this section. It includes a description of how this manual is structured, as well as general information and operating instructions at the level needed to safely power on and service this oscilloscope. A statement of the service strategy that this manual supports, and instructions for shipment of the Digitizing Oscilloscopes are found in this section.
- *Theory of Operation* contains circuit descriptions that support general service and fault isolation down to the module level.
- *Performance Verification* contains a collection of procedures for confirming that this Digitizing Oscilloscopes functions properly and meets warranted limits.
- *Adjustment Procedures* contains a collection of procedures for adjusting these Digitizing Oscilloscopes to meet warranted limits.
- *Maintenance* contains information and procedures for doing preventive and corrective maintenance of these Digitizing Oscilloscopes. Instructions for cleaning, for module removal and installation, and for fault isolation to a module are found here.
- *Options* contains information on servicing any of the factory-installed options that may be present in your oscilloscope.

- *Electrical Parts List* contains a statement referring you to *Mechanical Replaceable Parts*, where both electrical and mechanical modules are listed.
- *Diagrams* contains a block diagram and an interconnection diagram useful for isolating failed modules.
- *Mechanical Parts List* includes a table of all replaceable modules, their descriptions, and their Tektronix part numbers.

Manual Conventions



This manual uses certain conventions which you should become familiar with before doing service.

Modules Throughout this manual, any replaceable component, assembly, or part of these Digitizing Oscilloscopes is referred to generically as a module. In general, a module is an assembly, like a circuit board, rather than a component, like a resistor or an integrated circuit. Sometimes a single component is a module; for example, each chassis part of the oscilloscope is a module.

Safety Symbols and terms related to safety appear in the Safety Summary found at the beginning of this manual.

Symbols Besides the symbols related to safety, this manual uses the following symbols:

STOP. *The stop labels information which must be read in order to correctly do service and to avoid incorrectly using or applying service procedures.*

-  The clock icon labels procedure steps which require a pause to wait for the oscilloscope to complete some operation before you can continue.
-  Various icons such as the example icon at the left are used in procedures to help identify certain readouts and menu functions on screen.

Related Manuals

The TDS 684A and 744 Digitizing Oscilloscopes come with the following manuals:

TDS 684A and 744 User Manual (Tektronix part number 070-8991-XX) contains a tutorial to quickly show you how to operate the TDS 684A and 744 Digitizing Oscilloscopes and an in depth discussion of how to more completely use their features. Applications are also discussed.

TDS 684A & 744 Reference (Tektronix part number 070-8999-XX) contains a brief overview of oscilloscope operation.

TDS Family (400, 500A, 600A, and 744) Programmer Manual (Tektronix part number 070-8709-XX) contains information for programmed operation via the GPIB interface. Included is the complete command set, set up information, and programming examples.

TDS 684A & 744 Technical Reference (Tektronix part number 070-8990-XX) contains performance verification procedures and specifications.

Introduction

Service Strategy

STOP. Throughout this manual, any field-replaceable component, assembly, or part of this oscilloscope is referred to generically as a module.

This manual contains all the information needed for periodic maintenance of the TDS 684A and 744 Digitizing Oscilloscopes. (Examples of such information are procedures for checking performance and for readjustment.) Further, it contains all information for corrective maintenance down to the module level. This means that the procedures, diagrams, and other troubleshooting aids help isolate failures to a specific module, rather than to components of that module. Once a failure is isolated, replace the module with a fresh unit obtained from the factory.

All modules are listed in *Mechanical Parts List*. To isolate a failure to a module, use the fault isolation procedures found in Section 6, *Maintenance Information*. To remove and replace any failed module, follow the instructions in *Removal and Installation Procedures*, also found in Section 6.

Service Offerings

Tektronix provides service to cover repair under warranty as well as other services that may provide a cost-effective answer to your service needs.

Whether providing warranty repair service or any of the other services listed below, Tektronix service technicians, trained on Tektronix products, are best equipped to service your TDS 684A and 744 Digitizing Oscilloscopes. Tektronix technicians are apprised of the latest information on improvements to the product as well as the latest new options to the product.

Warranty Repair Service

Tektronix warrants this product for three years from date of purchase, excluding probes for which the warranty is one year. (The warranty appears after the title page and copyright page in this manual.) Tektronix technicians provide warranty service at most Tektronix service locations worldwide. Your Tektronix product catalog lists all service locations worldwide.

Repair or Calibration Service

The following services may be purchased to tailor repair and/or calibration of your TDS 684A and 744 Digitizing Oscilloscopes to fit your requirements.

Option 9C. When you order the TDS 684A and 744 Digitizing Oscilloscopes with option 9C, each one is shipped with a *Certificate of Calibration and Test Data Report*. This certificate provides traceability to the National Institute of Standards and Technology (NIST). It certifies procedures used to calibrate the oscilloscope comply with U. S. Military Standard 45662A.

At-Depot Service. Tektronix offers several standard-priced adjustment (calibration) and repair services:

- A single repair and/or adjustment.
- Calibrations using equipment and procedures that meet the traceability standards specific to the local area.
- Annual maintenance agreements that provide for either calibration and repair or calibration only of the oscilloscope.

Of these services, the annual maintenance agreement offers a particularly cost-effective approach to service for many owners of the TDS 684A and 744 Digitizing Oscilloscopes. Such agreements can be purchased to span several years.

On-Site Service. The annual maintenance agreement can be purchased with on-site service, with repair and calibration done at your facility. This service reduces the time your oscilloscope is out of service when calibration or repair is required.

Self Service

Tektronix supports repair to the module level by providing *Module Exchange* and *Module Repair and Return*.

Module Exchange. This service reduces down time for repair by allowing you to exchange most modules for remanufactured ones. Tektronix ships you an updated and tested exchange module from the Beaverton, Oregon service center, typically within 24 hours. Each module comes with a 90-day service warranty.

Module Repair and Return. This service returns to you within 10 days the same module that you shipped to Tektronix. The module shipped is repaired, tested, and returned to you from the Beaverton, Oregon service center. It is *not* updated to match current modules of the same type. Again, each module comes with a 90-day service warranty.

For More Information. Contact your local Tektronix service center or sales engineer for more information on any of the repair or adjustment services just described.

Before You Begin

This manual is for servicing the TDS 684A and 744 Digitizing Oscilloscopes. To prevent injury to yourself or damage to the oscilloscope, do the following tasks before you attempt service:

- Be sure you are a qualified service person.
- Read the Safety Summary found at the beginning of this manual.
- Read *Service Strategy* in this section and *Supplying Operating Power* in section 2.

When using this manual for servicing, be sure to heed all warnings, cautions, and notes.

Introduction

Specifications

This section begins with a general description of the traits of the TDS 684A and 744 Digitizing Oscilloscopes. Three sections follow, one for each of three classes of traits: *nominal traits*, *warranted characteristics*, and *typical characteristics*.

Product Description

The TDS 684A and 744 Digitizing Oscilloscopes are portable, four-channel instruments suitable for use in a variety of test and measurement applications and systems. Table 1-1 lists key features.

Table 1-1: Key Features of the TDS 684A and 744 Oscilloscopes

Feature	TDS 684A	TDS 744
Digitizing rate, maximum	5 GS/s on each channel simultaneously	2 GS/s
Analog bandwidth	1 GHz	500 MHz
Channels	Four, each with 8-bit resolution	
Record lengths, maximum	15,000 samples	50,000 samples (130,000 with option 1M)
Acquisition modes	Sample, envelope, and average	Sample, envelope, average, high-resolution, and peak-detect
Trigger modes	Include: edge, logic, and pulse. Video trigger, with option 05, modes include: NTSC, SECAM, PAL, HDTV, and FlexFormat.	
Display	Color for distinguishing among waveforms, measurements, and associated text	
Storage	1.44 Mbyte, 3.5 inch, DOS 3.3-or-later floppy disk. NVRAM storage for saving waveforms, hardcopies, and setups	
I/O	Full GPIB programmability. Hardcopy output using GPIB, RS-232, or Centronics ports	

User Interface

Use a combination of front-panel buttons, knobs, and on-screen menus to control the many functions of the oscilloscope. The front-panel controls are grouped according to function: vertical, horizontal, trigger, and special. Set a function you adjust often, such as vertical positioning or the time base setting, directly by its own front-panel knob. Set a function you change less often, such as vertical coupling or horizontal mode, indirectly using a selected menu.

Menus Pressing one (sometimes two) front-panel button(s), such as vertical menu, displays a *main* menu of related functions, such as coupling, bandwidth, etc., at the bottom of the screen. Pressing a main-menu button, such as coupling, displays a *side* menu of settings for that function, such as AC, DC, or GND (ground) coupling, at the right side of the screen. Pressing a side-menu button selects a setting such as DC.

Indicators On-screen readouts help you keep track of the settings for various functions, such as vertical and horizontal scale and trigger level. Some readouts use the cursors or the automatic parameter extraction feature (called measure) to display the results of measurements made or the status of the instrument.

General Purpose Knob Assign the general purpose knob to adjust a selected parameter function. More quickly change parameters by toggling the **SHIFT** button. Use the same method as for *selecting* a function, except the final side-menu selection assigns the general purpose knob to *adjust* some function, such as the position of measurement cursors on screen, or the setting for a channel fine gain.

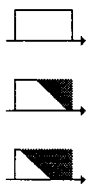

GUI The user interface also makes use of a GUI, or Graphical User Interface, to make setting functions and interpreting the display more intuitive. Some menu and status are displayed using iconic representations of function settings such as those shown here for full, 250 MHz and 20 MHz bandwidth. Such icons allow you to more readily determine status or the available settings.

Signal Acquisition System

The signal acquisition system provides four, full-featured vertical channels with calibrated vertical scale factors from 1 mV to 10 V per division. All channels can be acquired simultaneously.

Each of the full-featured channels can be displayed, vertically positioned, and offset, can have their bandwidth limited (250 MHz or 20 MHz) and their vertical coupling specified. Fine gain can also be adjusted.

Besides these channels, up to three math waveforms and four reference waveforms are available for display. (A math waveform results when you specify dual waveform operations, such as add, on any two channels. A reference waveform results when you save a waveform in a reference memory.)

Horizontal System

There are three horizontal display modes: main only, main intensified, and delayed only. You can select among various horizontal record length settings.

A feature called "Fit to Screen" allows you to view entire waveform records within the 10 division screen area. In other words, waveforms are compressed to fit on the screen. See Table 1-2.

Table 1-2: Record Length vs. Divisions per Record, Samples per Division and Sec/Div Sequence

Record Length	Divisions per Record	
	Sample/Division (Sec/Div Sequence)	
	Fit to Screen OFF 50 (1-2-5)	Fit to Screen ON (Sample/Div & Sec/Div Sequence varies)
500	10 divs	10 divs
1000	20 divs	10 divs
2500	50 divs	10 divs
5000	100 divs	10 divs
15000	300 divs	15 divs
50000 (TDS 744 only)	1,000 divs	10 divs
75000 (TDS 744 opt. 1M only)	1,500 divs	15 divs
100000 (TDS 744 opt. 1M only)	2,000 divs	15 divs
130000 (TDS 744 opt. 1M only)	2,600 divs	13 divs

Both the delayed only display and the intensified zone on the main intensified display may be delayed by time with respect to the main trigger. Both can be set to display immediately after the delay (delayed runs after main mode). The delayed display can also be set to display at the first valid trigger after the delay (delayed-triggerable modes).

The delayed display (or the intensified zone) may also be delayed by a selected number of events. In this case, the events source is the delayed-trigger source. The delayed trigger can also be set to occur after a number of events plus an amount of time.

Trigger System

The triggering system supports a varied set of features for triggering the signal-acquisition system. Trigger signals recognized include:

- Edge (main- and delayed-trigger systems): This familiar type of triggering is fully configurable for source, slope, coupling, mode (auto or normal), and holdoff.
- Logic (main-trigger system): This type of triggering can be based on pattern (asynchronous) or state (synchronous). In either case, logic triggering is configurable for sources, for boolean operators to apply to those sources, for logic pattern or state on which to trigger, for mode (auto or normal), and for holdoff. Time qualification may be selected in pattern mode. Another class of logic trigger, setup/hold, triggers when data in one trigger source changes state within the setup and hold times that you specify relative to a clock in another trigger source.
- Pulse (main-trigger system): Pulse triggering is configurable for triggering on runt or glitch pulses, or on pulse widths or periods inside or outside limits that you specify. It can also trigger on a pulse edge that has a slew rate faster or slower than the rate you specify. The pulse trigger is also configurable for source, polarity, mode, and holdoff.
- Video (with option 05: Video Trigger): Video triggering is compatible with standard NTSC, PAL, SECAM, and HDTV formats. An additional feature called FlexFormat™ (flexible format) allows the user to define the video format on which to trigger.

You can choose where the trigger point is located within the acquired waveform record by selecting the amount of pretrigger data displayed. Presets of 10%, 50%, and 90% of pretrigger data can be selected in the horizontal menu, or the general purpose knob can be assigned to set pretrigger data to any value within the 0% to 100% limits.

Acquisition Control

You can specify a mode and manner to acquire and process signals that matches your measurement requirements.

- Select the mode for interpolation (linear or $\sin(x)/x$). This can increase the apparent sample rate on the waveform when the maximum real-time rate is exceeded.
- Use sample, envelope, and average modes to acquire signals. (with the TDS 744, also use high-resolution and peak-detect modes)

- Set the acquisition to stop after a single acquisition (or sequence of acquisitions if acquiring in average or envelope modes) or after a limit condition has been met.
- Select channel sources for compliance with limit tests. You can direct the TDS to signal you or generate hard copy output either to a printer or to a floppy disk file based on the results. Also, you can create templates for use in limit tests.

On-Board User Assistance

Help and autoseg can assist you in setting up the Digitizing Oscilloscope to make your measurements.

Help Help displays operational information about any front-panel control. When help mode is in effect, manipulating any front-panel control causes the Digitizing Oscilloscope to display information about that control. When help is first invoked, an introduction to help is displayed on screen.

Autoseg Autoseg automatically sets up the Digitizing Oscilloscope for a viewable display based on the input signal.

Measurement Assistance

Once you have set up to make your measurements, the cursor and measure features can help you quickly make those measurements.

Cursor Three types of cursors are provided for making parametric measurements on the displayed waveforms. Horizontal bar cursors (H Bar) measure vertical parameters (typically volts). Vertical bar cursors (V Bar) measure horizontal parameters (typically time or frequency). Paired cursors measure both amplitude and time simultaneously. These are delta measurements; that is, measurements based on the difference between two cursors.

Both H Bar and V Bar cursors can also be used to make absolute measurements. For the H Bars, either cursor can be selected to read out its voltage with respect to any channels ground reference level. For the V Bars, the cursors measure time with respect to the trigger point (event) of the acquisition. The cursors can also control the portion of the waveform on which automatic measurements are made.

For time measurements, units can be either seconds or Hertz (for 1/time).

Specifications

With the video trigger option installed (Option 05), you can measure the video line number using the vertical cursors. You can measure IRE amplitude (NTSC) using the horizontal cursors with or without the video trigger option installed.

Measure

Measure can automatically extract parameters from the signal input to the Digitizing Oscilloscope. Any four out of the 25 parameters available can be displayed to the screen. The waveform parameters are measured continuously with the results updated on-screen as the Digitizing Oscilloscope continues to acquire waveforms.

Digital Signal Processing (DSP)

An important component of the multiprocessor architecture of this Digitizing Oscilloscope is Tektronix's proprietary digital signal processor, the DSP. This dedicated processor supports advanced analysis of your waveforms when doing such compute-intensive tasks as interpolation, waveform math, and signal averaging. It also teams with a custom display system to deliver specialized display modes (See *Display*, later in this description.)

Storage

Acquired waveforms may be saved in any of four nonvolatile REF (reference) memories or on a 3.5 inch, DOS 3.3-or-later compatible disk. Any or all of the saved waveforms may be displayed for comparison with the waveforms being currently acquired.

The source and destination of waveforms to be saved may be chosen. You can save any of the four channels to any REF memory or move a stored reference from one REF memory to another. Reference waveforms may also be written into a REF memory location via the GPIB interface.

I/O

The oscilloscope is fully controllable and capable of sending and receiving waveforms over the GPIB interface (IEEE Std 488.1–1987/IEEE Std 488.2–1987 standard). This feature makes the instrument ideal for making automated measurements in a production or research and development environment that calls for repetitive data taking. Self-compensation and self-diagnostic features built into the Digitizing Oscilloscope to aid in fault detection and servicing are also accessible using commands sent from a GPIB controller.

The oscilloscope can also output copies of its display using the hardcopy feature. This feature allows you to output waveforms and other on-screen information to a variety of graphic printers and plotters from the TDS front panel, providing hard copies without requiring you to put the TDS into a system-controller environment. You can make hardcopies in a variety of popular output formats,

such as PCX, TIFF, BMP, RLE, EPS, Interleaf, and EPS mono or color. You can also save hardcopies in a disk file in any of the formats above. The hardcopies obtained are based on what is displayed on-screen at the time hardcopy is invoked. The hardcopies can be stamped with date and time and spooled to a queue for printing at a later time. You can output screen information via GPIB, RS-232C, or Centronics interfaces.

Display

The TDS 684A and 744 Digitizing Oscilloscopes offer flexible display options. You can customize the following attributes of your display:

- Color: Waveforms, readouts, graticule, and variable persistence with color coding
- Intensity: waveforms, readouts, and graticule
- Style of waveform display(s): vectors or dots, intensified or non-intensified samples, infinite persistence, and variable persistence with color coding
- Interpolation method: $\text{Sin}(x)/x$ or Linear
- Display format: xy or yt with various graticule selections including NTSC and PAL to be used with video trigger (option 05)

Zoom

This oscilloscope also provides an easy way to focus in on those waveform features you wish to examine up close. By invoking zoom, you can magnify the waveform using the vertical and horizontal controls to expand (or contract) and position it for viewing.

Specifications

Nominal Traits

This section contains a collection of tables that list the various *nominal traits* that describe the TDS 684A and 744 oscilloscopes. Electrical and mechanical traits are included.

Nominal traits are described using simple statements of fact such as “Four, all identical” for the trait “Input Channels, Number of,” rather than in terms of limits that are performance requirements.

Table 1–3: Nominal Traits — Signal Acquisition System

Name	Description	
Bandwidth Selections	20 MHz, 250 MHz, and FULL	
Samplers, Number of	Four, simultaneous	
Digitized Bits, Number of	8 bits ¹	
Input Channels, Number of	Four	
Input Coupling	DC, AC, or GND	
Input Impedance Selections	1 M Ω or 50 Ω	
Ranges, Offset	Volts/Div Setting	Offset Range
	1 mV/div – 100 mV/div	± 1 V
	101 mV/div – 1 V/div	± 10 V
	1.01 V/div – 10 V/div	± 100 V
Range, Position	± 5 divisions	
Range, 1 M Ω Sensitivity	1 mV/div to 10 V/div ²	
Range, 50 Ω Sensitivity	1 mV/div to 1 V/div ¹	

¹ Displayed vertically with 25 digitization levels (DLs) per division and 10.24 divisions dynamic range with zoom off. A DL is the smallest voltage level change of the oscilloscope input that can be resolved by the 8-bit A-D Converter. Expressed as a voltage, a DL is equal to 1/25 of a division times the volts/division setting.

² The sensitivity ranges from 1 mV/div to 10 V/div (for 1 M Ω) or to 1 V/div (for 50 Ω) in a 1–2–5 sequence of coarse settings with Fit-to-Screen off. Between coarse settings, the sensitivity can be finely adjusted with a resolution equal to 1% of the more sensitive coarse setting. For example, between 50 mV/div and 100 mV/div, the volts/division can be set with 0.5 mV resolution.

Nominal Traits

Table 1-4: Nominal Traits — Time Base System

Name	Description
Range, Sample-Rate ^{1,3}	TDS 684A: 5 Samples/sec to 5 GSamples/sec on four channels simultaneously TDS 744: 5 Samples/sec to 2 GSamples/sec when acquiring 1 channel to 1 G Sample/sec when acquiring 2 channels, or to 500 MSamples/sec when acquiring 3 or 4 channels
Range, Interpolated Waveform Rate ^{2,3}	TDS 684A: 10 GSamples/sec to 250 GSamples/sec TDS 744: 1 GSamples/sec to 100 GSamples/sec
Range, Seconds/Division	TDS 684A: 0.2 ns/div to 10 s/div TDS 744: 0.5 ns/div to 10 s/div
Record Length Selection	500 samples, 1000 samples, 2500 samples 5000 samples, 15000 samples The TDS 744 also offers: 50000 samples and, with its option 1M, 75000, 100000, and 130000 samples

- ¹ The range of real-time rates, expressed in samples/second, at which a digitizer samples signals at its inputs and stores the samples in memory to produce a record of time-sequential samples.
- ² The range of waveform rates for interpolated (or equivalent-time on the TDS 744) waveform records.
- ³ The Waveform Rate (WR) is the equivalent sample rate of a waveform record. For a waveform record acquired by real-time sampling of a single acquisition, the waveform rate is the same as the real-time sample rate; for a waveform created by interpolation of real-time samples from a single acquisition or, on applicable products, the equivalent-time sampling of multiple acquisitions, the waveform rate created is faster than the real time sample rate. For all these cases, the waveform rate is $1/(\text{Waveform Interval})$ for the waveform record, where the waveform interval (WI) is the time between the samples in the waveform record.

Table 1-5: Nominal Traits — Triggering System

Name	Description	
Range, Delayed Trigger Time Delay	16 ns to 250 s	
Range, Events Delay	TDS 684A: 2 to 10,000,000 TDS 744: 1 to 10,000,000	
Range (Time) for Pulse-Glitch, Pulse-Width, Time-Qualified Runt Triggering, or Slew Rate Trigger, Delta Time	1 ns to 1 s	
Ranges, Setup and Hold for TimeSetup/Hold Violation Trigger	Feature	Min to max
	Setup Time	-100 ns to 100 ns
	Hold Time	-1 ns to 100 ns
	Setup + Hold Time	2 ns

Table 1-5: Nominal Traits — Triggering System (Cont.)

Name	Description	
	<p>For Setup Time, positive numbers mean a data transition before the clock edge and negative means a transition after the clock edge.</p> <p>For Hold Time, positive numbers mean a data transition after the clock edge and negative means a transition before the clock edge.</p> <p>Setup + Hold Time is the algebraic sum of the Setup Time and the Hold Time programmed by the user.</p>	
Ranges, Trigger Level or Threshold	Source	Range
	Any Channel	±12 divisions from center of screen
	Auxiliary	±8 V
	Line	±400 V
Video Trigger Modes of Operation (Option 05 Video Trigger)	<p>Supports the following video standards:</p> <ul style="list-style-type: none"> ■ NTSC (525/60) – 2 field mono or 4 field ■ PAL (625/50) – 2 field mono or SECAM, 8 field ■ HDTV – <ul style="list-style-type: none"> (787.5/60) (1050/60) (1125/60) (1250/60) ■ FlexFormat™ (user definable standards) <p>User can specify: field rate, number of lines, sync pulse width and polarity, line rate, and vertical interval timing.</p>	

Table 1-6: Nominal Traits — Display System

Name	Description
Video Display	Color display, 7 inch diagonal, with a display area of 5.04 inches horizontally by 3.78 inches vertically
Video Display Resolution	640 pixels horizontally by 480 pixels vertically
Waveform Display Graticule	Single Graticule: 401 × 501 pixels, 8 × 10 divisions, where divisions are 1 cm by 1 cm
Waveform Display Colors	Sixteen colors in infinite-persistence or variable persistence display with color coding

Nominal Traits

Table 1-7: Nominal Traits — GPIB Interface, Output Ports, and Power Fuse

Name	Description
Interface, GPIB	GPIB interface complies with IEEE Std 488-1987
Interface, RS-232	RS-232 interface complies with EIA/TIA 574 (talk only)
Interface, Centronics	Centronics interface complies with Centronics interface standard C332-44 Feb 1977, REV A
Interface, Video	VGA video output with levels that comply with EIA RS 343A standard. DB-15 connector
Logic Polarity for Main- and Delayed-Trigger Outputs	Negative TRUE. High to low transition indicates the trigger occurred.
Fuse Rating	Either of two fuses ¹ may be used: a 0.25" × 1.25" (UL 198.6, 3AG): 6 A FAST, 250 V or a 5 mm × 20 mm (IEC 127): 5 A (T), 250 V.

¹ Each fuse type requires its own fuse cap.

Table 1-8: Nominal Traits — Data Handling and Reliability

Name	Description
Time, Data-Retention, Nonvolatile Memory ^{1, 2}	≥ 5 years
Floppy disk	3.5 inch, 720 K or 1.44 Mbyte, DOS 3.3-or-later compatible

¹ The times that reference waveforms, stored setups, and calibration constants are retained when there is no power to the oscilloscope.

² Data is maintained by small lithium-thionyl-chloride batteries internal to the memory ICs. The amount of lithium is so small in these ICs that they can typically be safely disposed of with ordinary garbage in a sanitary landfill.

Table 1-9: Nominal Traits — Mechanical

Name	Description
Cooling Method	Forced-air circulation with no air filter. Clearance is required.
Construction Material	Chassis parts constructed of aluminum alloy; front panel constructed of plastic laminate; circuit boards constructed of glass laminate. Cabinet is aluminum and is clad in Tektronix Blue vinyl material.
Finish Type	Tektronix Blue vinyl-clad aluminum cabinet
Weight	<p>Standard TDS 684A Digitizing Oscilloscope</p> <p>14.1 kg (31 lbs), with front cover. TDS 684A: 24.0 kg (53 lbs), when packaged for domestic shipment TDS 744: 25.4 kg (56 lbs), when packaged for domestic shipment</p> <p>Rackmount TDS 684A Digitizing Oscilloscopes</p> <p>14.1 kg (31 lbs) plus weight of rackmount parts, for the rackmounted Digitizing Oscilloscopes (Option 1R).</p> <p>Rackmount conversion kit</p> <p>2.3 kg (5 lbs), parts only; 3.6 kg (8 lbs), parts plus package for domestic shipping</p>
Overall Dimensions	<p>Standard Digitizing Oscilloscope</p> <p>Height: 193 mm (7.6 in), with the feet installed</p> <p>Width: 445 mm (17.5 in), with the handle</p> <p>Depth: 434 mm (17.1 in), with the front cover installed</p> <p>Rackmount Digitizing Oscilloscope</p> <p>Height: 178 mm (7.0 in)</p> <p>Width: 483 mm (19.0 in)</p> <p>Depth: 558.8 mm (22.0 in)</p>

Nominal Traits



Warranted Characteristics

This section lists the various *warranted characteristics* that describe the TDS 684A and 744 Digitizing Oscilloscopes. Electrical and environmental characteristics are included.

Warranted characteristics are described in terms of quantifiable performance limits which are warranted.

NOTE. *In these tables, those warranted characteristics that are checked in the procedure Performance Verification appear in **boldface type** under the column Name.*

As stated above, this section lists only warranted characteristics. A list of *typical characteristics* starts on page 1-21.

Performance Conditions

The performance limits in this specification are valid with these conditions:

- The oscilloscope must have been calibrated/adjusted at an ambient temperature between +20° C and +30° C.
- The oscilloscope must be in an environment with temperature, altitude, humidity, and vibration within the operating limits described in these specifications.
- The oscilloscope must have had a warm-up period of at least 20 minutes.
- The oscilloscope must have had its signal-path-compensation routine last executed after at least a 20 minute warm-up period at an ambient temperature within $\pm 5^{\circ}$ C of the current ambient temperature.

Warranted Characteristics

Table 1–10: Warranted Characteristics — Signal Acquisition System

Name	Description		
Accuracy, DC Gain	TDS 684A: $\pm 1.5\%$ for all sensitivities from 2 mV/div to 10 V/div $\pm 2.0\%$ at 1 mV/div sensitivity TDS 744: $\pm 1\%$ for all sensitivities from 1 mV/div to 10 V/div with offset from 0 V to $\pm 100\text{V}$		
Accuracy, Offset	Volts/Div Setting	TDS 684A Offset Accuracy	TDS 744 Offset Accuracy
	1 mV/div – 100 mV/div	$\pm((0.2\% \times \text{Net Offset}^1) + 1.5 \text{ mV} + (0.6 \text{ div} \times \text{V/div}))$	$\pm((0.2\% \times \text{Net Offset}^1) + 1.5 \text{ mV} + (0.1 \text{ div} \times \text{V/div setting}))$
	101 mV/div – 1 V/div	$\pm((0.25\% \times \text{Net Offset}^1) + 15 \text{ mV} + (0.6 \text{ div} \times \text{V/div}))$	$\pm((0.25\% \times \text{Net Offset}^1) + 15 \text{ mV} + (0.1 \text{ div} \times \text{V/div setting}))$
	1.01 V/div – 10 V/div	$\pm((0.25\% \times \text{Net Offset}^1) + 150 \text{ mV} + (0.6 \text{ div} \times \text{V/div}))$	$\pm((0.25\% \times \text{Net Offset}^1) + 150 \text{ mV} + (0.1 \text{ div} \times \text{V/div setting}))$
Analog Bandwidth, DC-50 Ω Coupled and Bandwidth selection is FULL	Volts/Div	684A Bandwidth ²	744 Bandwidth ²
	10 mV/div – 1 V/div	DC – 1 GHz	DC – 500 MHz
	5 mV/div – 9.95 mV/div	DC – 750 MHz	DC – 500 MHz
	2 mV/div – 4.98 mV/div	DC – 600 MHz	DC – 500 MHz
	1 mV/div – 1.99 mV/div	DC – 500 MHz	DC – 450 MHz
Analog Bandwidth, DC-50 Ω Coupled with P6245 Probe and Bandwidth selection is FULL	Volts/Div as Read Out on Screen	684A Bandwidth ²	744 Bandwidth ²
	10 mV/div – 100 V/div	(Not Applicable)	(Not Applicable)
	100 mV/div – 10 V/div	DC – 1 GHz	DC – 1 GHz
	50 mV/div – 99.5 mV/div	DC – 750 MHz	DC – 900 MHz
	20 mV/div – 49.8 mV/div	DC – 600 MHz	DC – 600 MHz
	10 mV/div – 19.9 mV/div	DC – 500 MHz	DC – 500 MHz
Analog Bandwidth, DC-1M Ω Coupled with P6139A Probe and Bandwidth selection is FULL	Volts/Div as Read Out on Screen	684A Bandwidth ²	744 Bandwidth ²
	10 mV/div – 100 V/div	500 MHz	500 MHz
	100 mV/div – 10 V/div	500 MHz	500 MHz
	50 mV/div – 99.5 mV/div	500 MHz	500 MHz
	20 mV/div – 49.8 mV/div	500 MHz	500 MHz
	10 mV/div – 19.9 mV/div	400 MHz	500 MHz
Crosstalk (Channel Isolation)	$\geq 100:1$ at 100 MHz and $\geq 30:1$ at the rated bandwidth for any two channels having equal Volts/Div settings		

Table 1–10: Warranted Characteristics — Signal Acquisition System (Cont.)

Name	Description
Delay Between Channels, Full Bandwidth	≤100 ps for any two channels with equal Volts/Div and Coupling settings
Input Impedance, DC–1 MΩ Coupled	1 MΩ ±0.5% in parallel with 10 pF ±3 pF
Input Impedance, DC–50 Ω Coupled	50 Ω ±1% with VSWR ≤1.3:1 from DC – 500 MHz, ≤1.5:1 from 500 MHz – 1 GHz
Input Voltage, Maximum, DC–1 MΩ, AC–1 MΩ, or GND Coupled	±400 V (DC + peak AC); derate at 20 dB/decade above 1 MHz
Input Voltage, Maximum, DC-50 Ω or AC–50 Ω Coupled	5 V _{RMS} , with peaks ≤ ±30 V
Lower Frequency Limit, AC Coupled	TDS 684A: ≤10 Hz when AC–1 MΩ Coupled; ≤200 kHz when AC–50 Ω Coupled ³

- ¹ **Net Offset = Offset – (Position × Volts/Div). Net Offset is the nominal voltage level at the oscilloscope input that corresponds to the center of the A-D converter's dynamic range. Offset Accuracy is the accuracy of this voltage level.**
- ² **The limits given are for the ambient temperature range of 0°C to +30°C. Reduce the upper bandwidth frequencies by 5 MHz for the TDS 684A or by 2.5 MHz for the TDS 744 for each °C above +30°C.**
- ³ **The AC Coupled Lower Frequency Limits are reduced by a factor of 10 when 10X passive probes are used.**

Table 1–11: Warranted Characteristics — Time Base System

Name	Description
Accuracy, Long Term Sample Rate and Delay Time	TDS 684A: ±100 ppm over any ≥1 ms interval TDS 744: ±25 ppm over any ≥1 ms interval

Table 1–12: Warranted Characteristics — Triggering System

Name	Description	
Sensitivity, Edge-Type Trigger, Coupling set to "DC" ¹	Trigger Source	Sensitivity
	Any Channel	TDS 684A: 0.35 division from DC to 50 MHz, increasing to 1 division at 1 GHz TDS 744: 0.35 division from DC to 50 MHz, increasing to 1 division at 500 MHz
	Auxiliary	TDS 684A: 250 mV from DC to 50 MHz, increasing to 500 mV at 100 Mhz TDS 744: 400 mV from DC to 50 MHz, increasing to 750 mV at 100 Mhz
Accuracy (Time) for Pulse-Glitch or Pulse-Width Triggering	Time Range	Accuracy
	1 ns to 1 μs	±(20% of Setting + 0.5 ns)
	1.02 μs to 1 s	±(100 ns + 0.01% of Setting)

Warranted Characteristics

Table 1-12: Warranted Characteristics — Triggering System (Cont.)

Name	Description
Input Signal Sync Amplitude for Stable Triggering, NTSC and PAL modes (Option 05 Video Trigger)	Field selection "Odd", "Even", or "All": 0.6 division to 4 divisions Field selection "Numeric": 1 division to 4 divisions (NTSC mode)
Jitter (Option 05 Video Trigger)	60 ns _{p-p} on NTSC or PAL signal

¹ The minimum sensitivity for obtaining a stable trigger. A stable trigger results in a uniform, regular display triggered on the selected slope. The trigger point must not switch between opposite slopes on the waveform, and the display must not "roll" across the screen on successive acquisitions. The TRIG'D LED stays constantly lighted when the SEC/DIV setting is 2 ms or faster but may flash when the SEC/DIV setting is 10 ms or slower.

Table 1-13: Warranted Characteristics — Output Ports, Probe Compensator, and Power Requirements

Name	Description	
Logic Levels, Main- and Delayed-Trigger Outputs	Characteristic	Limits
	Vout (HI) Vout (LO)	≥2.5 V open circuit; ≥1.0 V into a 50 Ω load to ground ≤0.7 V into a load of ≤4 mA; ≤0.25 V into a 50 Ω load to ground
Output Voltage and Frequency, Probe Compensator	Characteristic	Limits
	Output Voltage Frequency	0.5 V (base-top) ±1% into a ≥50 Ω load 1 kHz ±5%
Output Voltage, Signal Out (CH 3¹)	For TDS 684A: 20 mV/division ±20% into a 1 MΩ load; 10 mV/division ±20% into a 50 Ω load For TDS 744: 22 mV/division ±20% into a 1 MΩ load; 11 mV/division ±20% into a 50 Ω load	
Source Voltage	90 to 250 VAC _{RMS} , continuous range	
Source Frequency	45 Hz to 440 Hz	
Power Consumption	≤300 W (450 VA)	

¹ CH 3 signal out is present at the rear panel if CH 3 is selected as the trigger source for the main and/or delayed trigger systems. It is not available when a channel other than CH3 is the source for the Video Trigger when Option 05 is installed.

Table 1-14: Warranted Characteristics — Environmental

Name	Description
Atmospherics	Temperature (no diskette in floppy drive): TDS 684A: Operating: +4° C to +45° C TDS 744: Operating: +4° C to +50° C Non-operating: -22° C to +60° C Relative humidity (no diskette in floppy drive): Operating: 20% to 80%, at or below +32° C, upper limit de-rates to 30% relative humidity at +45° C Non-operating: 5% to 90%, at or below +41° C, upper limit de-rates to 30% relative humidity at 60° C Altitude: To 4570 m (15,000 ft.), operating To 12190 m (40,000 ft.), non-operating
Dynamics	Random vibration (floppy diskette not installed): 0.31 g rms, from 5 to 500 Hz, 10 minutes each axis, operating 3.07 g rms, from 5 to 500 Hz, 10 minutes each axis, non-operating
Emissions ^{1,2}	Meets or exceeds the requirements of the following standards: Vfg. 243/1991 Amended per Vfg. 46/1992 FCC Code of Federal Regulations, 47 CFR, Part 15, Subpart B, Class A EN 50081-1 European Community Requirements EN55022 Radiated Emissions Class B EN55022 Class B Conducted Emission EN60555-2 Power Harmonics
Susceptibility ^{1,2}	Meets or exceeds the EMC requirements of the following standards: EN 50082-1 European Community Requirements IEC 801-2 Electrostatic Discharge IEC 801-3 Radiated Susceptibility IEC 801-4 Fast Transients IEC 801-5 AC Surge

Warranted Characteristics

Table 1-14: Warranted Characteristics — Environmental (Cont.)

Name	Description
Third Party Certification	Conforms to and is certified where appropriate to: UL 1244 CSA-C22.2 No. 231

^{1,2} VGA output cable needs to be terminated, if connected at all, for the instrument to meet these standards. The test will pass with LCOM part # CTL3VGAMM-5.

^{1,2} The GPIB cable connected to the instrument for certain of the emissions tests must be “low EMI” having a high-quality outer shield connected through a low impedance to both connector housings. Acceptable cables are Tektronix part numbers 012-0991-00, -01, -02, and -03. In order to maintain the EMI performance conforming to the above regulations, the following cables, or their equivalent, should be used: a shielded Centronics cable, 3 meters in length, part number 012-1214-00, and a shielded RS-232 cable, 2.7 meters in length, CA part number 0294-9.

Typical Characteristics

This subsection contains tables that list the various *typical characteristics* which describe the TDS 684A and 744 Digitizing Oscilloscopes.

Typical characteristics are described in terms of typical or average performance. Typical characteristics are not warranted.

Table 1–15: Typical Characteristics — Signal Acquisition System

Name	Description		
Accuracy, Delta Time Measurement	The limits are given in the following table for signals having amplitude greater than 5 divisions, reference level = 50%, filter set to (sinX/X), acquired at 5 mV/div or greater. For the TDS 744, pulse duration < 10 div. Channel skew not included.		
	For the Single Shot condition, $1.4 \leq T_r/S_i \leq 4$ for the TDS 684A and $1.4 \leq T_r/S_i \leq 5$ for the TDS 744, where S_i is the sample interval and T_r is the displayed rise time.		
	TDS 684A: For the averaged condition, $1.4 \leq T_r/W_i \leq 40$, where W_i is the Waveform Interval, as described elsewhere in these specifications.		
	TDS 684A: Extra error in the measurement will occur for two-channel measurements due to channel-to-channel skew. This spec is described elsewhere in these specifications.		
	Conditions	Time Measurement Accuracy	
	Single Shot or Sample mode (or HiRes mode on the TDS 744), Full Bandwidth selected	TDS 684A: $\pm(0.20 \times \text{sample interval}) + (100 \text{ ppm} \times \text{Reading}) + (0.05 \times W_i)$ TDS 684A example: at 5 GS/s, 5 ns/div, measuring a 40 ns wide pulse, accuracy = $\pm(40 \text{ ps} + 4 \text{ ps} + 5 \text{ ps}) = \pm 49 \text{ ps}$. TDS 744: $\pm \geq 0.15 \text{ sample interval} + 25 \text{ ppm} \times \text{Reading} + t/\text{div}/1000$ TDS 744 example: at 4 Gs/s, accuracy = 37.5 ps	
	≥ 100 Averages, Full Bandwidth selected. TDS 744: repetitive	TDS 684A: $\pm(10 \text{ ps} + (100 \text{ ppm} \times \text{Reading}) + (0.25 \times W_i))$ TDS 744: $20 \text{ ps} + 25 \text{ ppm} \times \text{Reading} + t/\text{div}/1000$	
Calculated Rise Time ¹	Volts/Div Setting	684A Rise Time	744 Rise Time
	10 mV/div – 1 V/div	450 ps	800 ps
	5 mV/div – 9.95 mV/div	600 ps	800 ps
	2 mV/div – 4.98 mV/div	750 ps	1.140 ns
	1 mV/div – 1.99 mV/div	900 ps	1.33 ns

Typical Characteristics

Table 1–15: Typical Characteristics — Signal Acquisition System (Cont.)

Name	Description				
Effective Bits — TDS 684A The chart on the right gives the typical effective bits for a 9-division p-p sine-wave input, 50 mV/div, 10 ns/div (5 GS/s), with a record length of 1000 points:	Input Frequency		Effective Bits		
	98 MHz		6.3 bits		
	245 MHz		6.0 bits		
	490 MHz		5.5 bits		
	990 MHz		5.2 bits		
Effective Bits — TDS 744 The chart on the right gives the typical effective bits for a sine wave adjusted to 9.2 divisions at 1 MHz, 50 mV/div @ 25° C	Input Frequency		Sample Rate		
			2 GS/s	1 MS/s & HiRes	
	1 MHz – 9.2 divs		6.8 bits	9.7 bits	
	500 MHz – 6.5 divs		6.8 bits	N/A	
Frequency Limit, Upper, 250 MHz Bandwidth Limited	250 MHz				
Frequency Limit, Upper, 20 MHz Bandwidth Limited	20 MHz				
Step Response Settling Errors	Volts/Div Setting	± Step Amplitude	Settling Error (%)² at		
			20 ns	100 ns	20 ms
	1 mV/div – 100 mV/div	≤2 V	0.5%	0.2%	0.1%
	101 mV/div – 1 V/div	≤20 V	1.0%	0.5%	0.2%
	1.01 V/div – 10 V/div	≤200 V	1.0%	0.5%	0.2%

¹ The numbers given are valid 0°C to +30°C and will increase as the temperature increases due to the degradation in bandwidth. Rise time is calculated from the bandwidth. It is defined by the following formula:

$$TDS\ 684A\ Rise\ Time\ (ns) = \frac{450}{BW\ (MHz)} \qquad TDS\ 744\ Rise\ Time\ (ns) = \frac{400}{BW\ (MHz)}$$

Note that if you measure rise time, you must take into account the rise time of the test equipment (signal source, etc.) that you use to provide the test signal. That is, the measured risetime (RT_m) is determined by the instrument risetime (RT_i) and the risetime of the test signal source (RT_{gen}) according to the following formula:

$$RT_m^2 = RT_i^2 + RT_{gen}^2$$

² The values given are the maximum absolute difference between the value at the end of a specified time interval after the mid-level crossing of the step, and the value one second after the mid-level crossing of the step, expressed as a percentage of the step amplitude.

Table 1–16: Typical Characteristics — Triggering System

Name	Description	
Accuracy, Trigger Level or Threshold, DC Coupled (for signals having rise and fall times ≥ 20 ns)	Trigger Source	Accuracy
	Any Channel	$\pm(2\% \times \text{Setting} - \text{Net Offset}) + (0.3 \text{ div} \times \text{Volts/div Setting}) + \text{Offset Accuracy}$
	Auxiliary	Not calibrated or specified
Input, Auxiliary Trigger	The input resistance is ≥ 1.5 k Ω ; the maximum safe input voltage is ± 20 V (DC + peak AC).	
Trigger Position Error, Edge Triggering	Acquisition Mode	Trigger-Position Error^{1,2}
	Sample, Average	$\pm(1 \text{ Waveform Interval} + 1 \text{ ns})$
	Envelope	$\pm(2 \text{ Waveform Intervals} + 1 \text{ ns})$
Holdoff, Variable, Main Trigger	For all Time/Division ranges, the minimum holdoff is 250 ns and the maximum holdoff is 12 seconds. The minimum resolution is 8 ns for settings ≤ 1.2 μ s.	
Lowest Frequency for Successful Operation of "Set Level to 50%" Function	30 Hz	
Sensitivity, Edge Trigger, Not DC Coupled ³	Trigger Source	Typical Signal Level for Stable Triggering
	AC	Same as the DC-coupled limits for frequencies above 60 Hz. Attenuates signals below 60 Hz.
	Noise Reject	Three times the DC-coupled limits.
	High Frequency Reject	One and one-half times the DC-coupled limits from DC to 30 kHz. Attenuates signals above 30 kHz.
	Low Frequency Reject	One and one-half times the DC-coupled limits for frequencies above 80 kHz. Attenuates signals below 80 kHz.
Sensitivities, Logic Trigger and Events Delay, DC Coupled ⁴	1.0 division, from DC to 500 MHz, at vertical settings > 10 mV/div and ≤ 1 V/div at the BNC input	
Sensitivities, Pulse-Type Runt Trigger ⁵	1.0 division, from DC to 500 MHz, at vertical settings > 10 mV/div and ≤ 1 V/div at the BNC input	
Sensitivities, Pulse-Type Trigger Width and Glitch ⁶	1.0 division, at vertical settings > 10 mV/div and ≤ 1 V/div at the BNC input	

Typical Characteristics

Table 1-16: Typical Characteristics — Triggering System (Cont.)

Name	Description			
Width, Minimum Pulse and Rearm, for Logic Triggering or Events Delay	For vertical settings > 10 mV/div and ≤ 1 V/div at the BNC input			
	Triggering Type	Minimum Pulse Width	Minimum Re-Arm Width	Minimum Time Between Channels⁷
	Logic	Not Applicable	1 ns	1 ns
	Events Delay	1 ns (for either + or – pulse widths)	Not Applicable	2 ns
Width, Minimum Pulse and Rearm, for Pulse Triggering The minimum pulse widths and rearm widths and transition times ⁸ required for Pulse-Type triggering.	For vertical settings > 10 mV/div. and 3 1 V/div at the BNC input			
	Pulse Class	Minimum Pulse Width	Minimum Re-Arm Width	
	Glitch	1 ns	2 ns + 5% of Glitch Width Setting	
	Runt	2 ns	2 ns	
	Time-Qualified Runt	2 ns	TDS 684A: 8.5 ns + 5% of Width Setting TDS 744: 7 ns + 5% of Width Setting	
	Width	1 ns	2 ns + 5% of Width Upper Limit Setting	
	Slew Rate	600 ps ⁸	TDS 684A: 8.5 ns + 5% of delta Time Setting TDS 744: 7 ns + 5% of delta Time Setting	
Input Signal Sync Amplitude for Stable Triggering, HDTV and FLEXFMT modes (Option 05 Video Trigger)	All field selections: 0.6 division to 4 divisions			
Jitter for HDTV mode (Option 05 Video Trigger)	17 ns _{p-p}			
Sync Width Flex Format and HDTV modes (Option 05 Video Trigger)	min. 400 ns for HDTV signals			
Sync Duty Cycle, Flex Format and HDTV modes (Option 05 Video Trigger)	min. 50 to 1			
Hum Rejection (Option 05 Video Trigger)	NTSC and PAL: –20 dB without any trigger spec deterioration. Triggering will continue down to 0 dB with some performance deterioration.			

- ¹ The trigger position errors are typically less than the values given here. These values are for triggering signals having a slew rate at the trigger point of ≥ 0.5 division/ns.
- ² The waveform interval (WI) is the time between the samples in the waveform record. Also, see the footnote for the characteristics *Sample Rate Range or Interpolated Waveform Rates* in Table 1-4, on page 1-10.
- ³ The minimum sensitivity for obtaining a stable trigger. A stable trigger results in a uniform, regular display triggered on the selected slope. The trigger point must not switch between opposite slopes on the waveform, and the display must not “roll” across the screen on successive acquisitions. The TRIG'D LED stays constantly lighted when the SEC/DIV setting is 2 ms or faster but may flash when the SEC/DIV setting is 10 ms or slower.

Table 1–16: Typical Characteristics — Triggering System (Cont.)

Name	Description
4	The minimum signal levels required for stable logic or pulse triggering of an acquisition, or for stable counting of a DC-coupled, events-delay signal. Also, see the footnote for <i>Sensitivity, Edge-Type Trigger, DC Coupled</i> in this table. (Stable counting of events is counting that misses no events and produces no extra “phantom” events.)
5	The minimum signal levels required for stable runt pulse triggering of an acquisition. Also, see the footnote for <i>Sensitivity, Edge-Type Trigger, DC Coupled</i> in this table. (Stable counting of events is counting that misses no events.)
6	The minimum signal levels required for stable pulse width or glitch triggering of an acquisition. Also, see the footnote for <i>Sensitivity, Edge-Type Trigger, DC Coupled</i> in this table. (Stable counting of events is counting that misses no events.)
7	For Logic, time between channels refers to the length of time a logic state derived from more than one channel must exist to be recognized. For Events, the time is the minimum time between a main and delayed event that will be recognized if more than one channel is used.
8	For Slew Rate Triggering, this is the minimum transition time, defined to be the time the user’s signal spends between the two trigger threshold settings.

Typical Characteristics

Installation

Supplying Operating Power

NOTE. Read all information and heed all warnings in this subsection before connecting the oscilloscope to a power source.



WARNING. AC POWER SOURCE AND CONNECTION. The oscilloscope operates from a single-phase power source. It has a three-wire power cord and two-pole, three-terminal grounding type plug. The voltage to ground (earth) from either pole of the power source must not exceed the maximum rated operating voltage, 250 volts.

Before making connection to the power source, be sure the digitizing oscilloscope has a suitable two-pole, three-terminal grounding-type plug.

GROUNDING. This instrument is safety Class 1 equipment (IEC designation). All accessible conductive parts are directly connected through the grounding conductor of the power cord to the grounded (earthing) contact of the power plug.



WARNING. The power input plug must be inserted only in a mating receptacle with a grounding contact where earth ground has been verified by a qualified service person. Do not defeat the grounding connection. Any interruption of the grounding connection can create an electric shock hazard.

For electric shock protection, the grounding connection must be made before making connection to the instrument's input or output terminals.

Power Cord Information

A power cord with appropriate plug configuration is supplied with each Digitizing Oscilloscope. Table 2-1 gives the color-coding of the conductors in the power cord. If you require a power cord other than the one supplied, refer to Table 2-2, Power Cord Identification.

Table 2-1: Power-Cord Conductor Identification

Conductor	Color	Alternate Color
Ungrounded (Line)	Brown	Black
Grounded (Neutral)	Light Blue	White
Grounded (Earthing)	Green/Yellow	Green

Table 2-2: Power Cord Identification

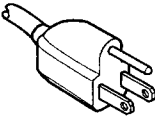
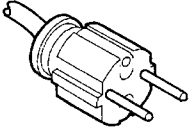
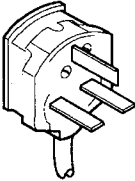
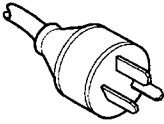
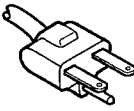
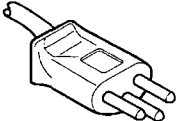
Plug Configuration	Normal Usage	Option Number
	North America 125 V	Standard
	Europe 230 V	A1
	United Kingdom 230 V	A2
	Australia 230 V	A3
	North America 230 V	A4
	Switzerland 230 V	A5

Operating Voltage

This oscilloscope operates with any line voltage from 90–250 VAC_{RMS} with any line frequency from 45–440 Hz. There are two fuses, either of which may be used throughout the line voltage and frequency ranges. (The two fuses are not totally interchangeable as each requires a different fuse cap.)

Memory Backup Power

Memory modules with on-board batteries allow the TDS 684A and 744 Digitizing Oscilloscopes to retain some types of data upon loss of the AC power source. The stored adjustment constants, saved front-panel settings, current front-panel settings (instrument status), and waveforms saved in memory are retained.

The on-board batteries of the memory modules have a shelf life of about five years. Partial or total loss of stored settings upon power on may indicate that the memory modules need to be replaced.

Operating Environment

The following environmental requirements are provided to ensure proper operation and long instrument life.

Operating Temperature

Operate Digitizing Oscilloscopes where the ambient air temperature is from 4° C to +45° C (+50° C for the TDS 744) with no diskette in the floppy drive. Store the oscilloscopes in ambient temperatures from -22° C to +60° C with no diskette in the floppy drive. After storage at temperatures outside the operating limits, allow the chassis to stabilize at a safe operating temperature before applying power.

Ventilation Requirements

The Digitizing Oscilloscopes are cooled by air drawn in and exhausted through their cabinet side panels by an internal fan. To ensure proper cooling of the oscilloscope, allow at least two inches clearance on both sides and 3/4 inch on the bottom of the oscilloscope. (The feet on the bottom of the oscilloscope provide the required clearance when set on flat surfaces.) The top of the oscilloscope does not require ventilation clearance.



CAUTION. *If air flow is restricted, the Digitizing Oscilloscopes's power supply may temporarily shut down.*

Applying and Interrupting Power

Consider the following information when you power on or power off the instrument, or when power is interrupted due to an external power failure.

Power On

Upon power on, the oscilloscope runs a power-on self check. If it passes, the oscilloscope displays a "passed" status message and a prompt to press CLEAR MENU to continue. If it fails, the oscilloscope displays a diagnostic log that identifies the area(s) that failed and a prompt to press CLEAR MENU to

continue. See Section 6, *Maintenance*, for information on diagnostics and fault isolation.

Power Off



CAUTION. *DO NOT power off the oscilloscope when either running a signal path compensation or when doing any of the adjustments described in Section 5, Adjustment Procedures. To do so might result in the loss of internally stored adjustment constants.*

In general, do not power off the instrument when doing operations that affect the data types listed in Table 1-1. Wait for the instrument to finish the operation when doing adjustments, saving waveforms, or saving setups.

Improper power off or unexpected loss of power to the oscilloscope can result in the following corruptions of non-volatile RAM (NVRAM). The following table describes the messages displayed when power is restored after an abnormal power off.

Table 2-3: Effects of Corrupted Data

Corrupted Data Type	Results
Adjustment Constants:	
Signal Path Compensation	A signal path compensation is required.
Voltage Reference	A voltage reference adjustment is required (Section 5)
Frequency Response	A frequency response adjustment is required (Section 5)
Error Log	Errors logged are lost
Reference Waveforms	Waveform Lost
Saved Setups	Setup Lost

Repackaging Instructions

Use a corrugated cardboard shipping carton having a test strength of at least 275 pounds and with an inside dimension at least six inches greater than the instrument dimensions.

If the instrument is being shipped to a Tektronix Service Center, enclose the following information: the owner's address, name and phone number of a contact person, type and serial number of the instrument, reason for returning, and a complete description of the service required.

Seal the shipping carton with an industrial stapler or strapping tape.

Mark the address of the Tektronix Service Center and also your own return address on the shipping carton in two prominent locations.

Installed Options

Your instrument may be equipped with one or more instrument options. Except for the line-cord options described by Table 2-2 (on page 2-2 of this section), all options and optional accessories are listed and described in Section 7, *Options*. For further information and prices of instrument options, see your Tektronix Products catalog or contact your Tektronix Field Office.

Installation

Operating Instructions

Before doing service, read the following operating instructions. These instructions are at the level appropriate for servicing these Digitizing Oscilloscopes. The *User Manual* contains more complete operating instructions.

Additional instructions are integrated into the service procedures found in later sections of this manual. For instance, the procedures found in the section *Performance Verification* contain instructions for making the front-panel settings required to check each instrument characteristic included there. Also, the general instructions for operating these Digitizing Oscilloscopes' internal diagnostic routines are found in Section 6, *Maintenance*. You may also find the *Product Description* in Section 1 useful for understanding how the oscilloscope functions.

Screen Layout

Figure 2-1 on page 2-8 shows the screen layout. This figure illustrates a full graticule. You may also select a grid, crosshair, or frame graticule from the display menu.

Basic Procedures

How to Power On

Push the principal power switch found on the rear panel of the oscilloscope, then push the **ON/STBY** (standby) switch to toggle the oscilloscope into operation. The switch at the rear panel is the true power disconnect switch. The **ON/STBY**(standby) switch simply toggles operation on and off.



WARNING. *The principal power switch at the rear panel is the true power disconnect switch. The **ON/STBY** (standby) switch simply toggles operation on and off. When connected to a power source and when the principal power switch is on, the internal power supplies and much of the other circuitry of these Digitizing Oscilloscopes are energized regardless of the setting of the **ON/STBY** switch.*

Operating Instructions

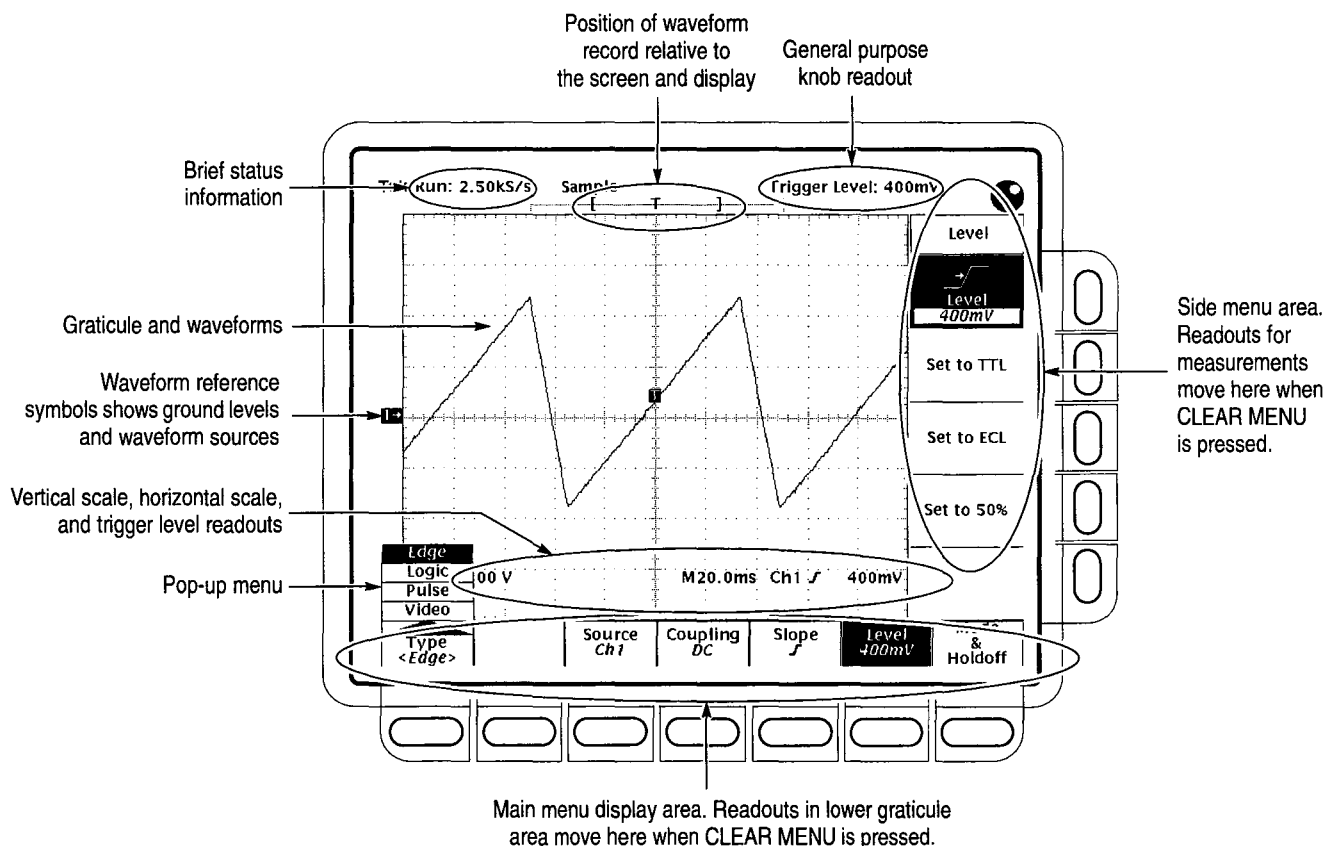

Figure 2-1: Map of Display Functions

How to Use Help

Push the **HELP** front-panel button to enter help mode. Front-panel knobs and buttons now display information about their function when turned or pushed. Push **HELP** again to exit help mode.

To get help information on a menu item, display the menu desired (if you are in help mode, exit help first). Push **HELP**. Now the menu buttons display information about their function when pushed.

How to Use the Status Menu

Push the **SHIFT**, then the **STATUS** front-panel buttons to display the status menu. You will find messages reflecting the state of the acquisition system, whether it is running or stopped (and if it is stopped, why), as well as setup-related information.

How to Set Functions

Most functions can be set either by using one (or two) front-panel button(s) or knob(s), or by pushing a front-panel button to use a main menu, and then a side-menu button to set the function. The following steps illustrate both procedures.

1. Locate the block that contains the function to be set.

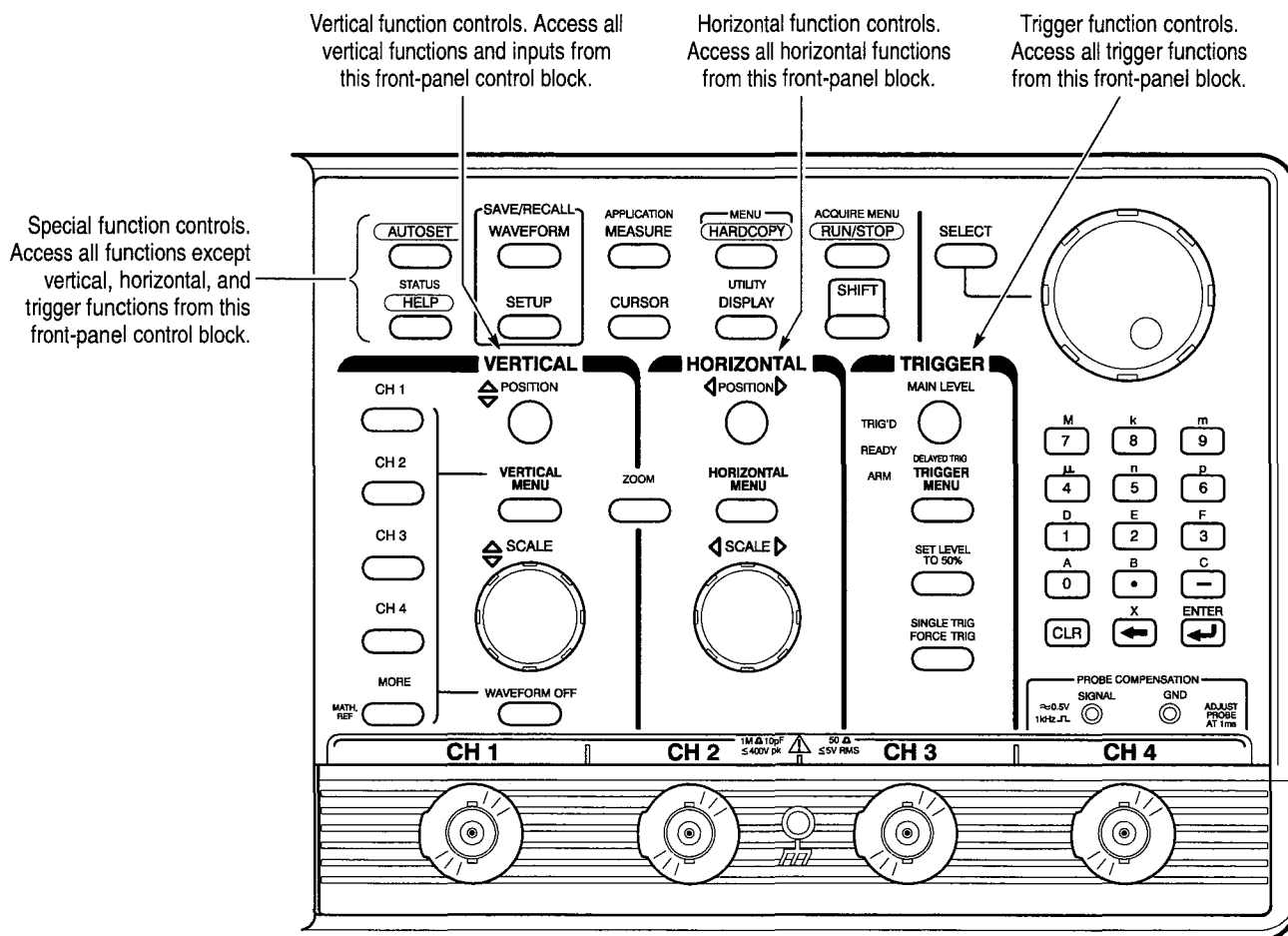

Operating Instructions

2. Select the waveform source(s). Position, scale, and set trigger level for waveform source(s) directly from the front-panel. The steps that follow provide examples of possible control selections.

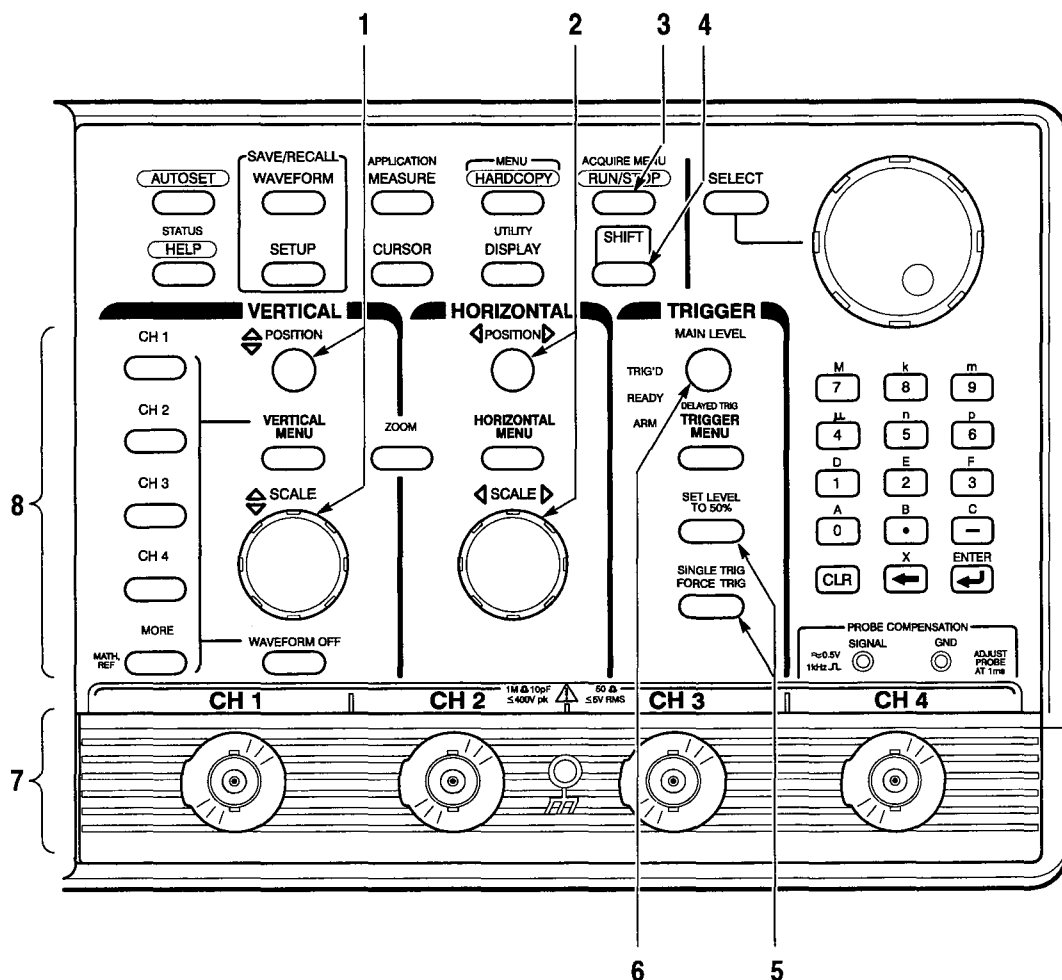

- a. Input waveforms into these channels (7). Example: **CH 1**.
- b. Push any channel's button (8) to display its waveform. The last channel turned on determines which waveform is positioned and scaled. The indicator above the channel last selected is lighted. Example: Push **CH 1**; then **CH 2**.
- c. Vertically (1) and horizontally (2) scale and position the waveform(s) selected. Example: Set the scale to 100 mV/div and center the waveform on screen.
- d. Stop and start acquiring waveforms (3). Example: Push **RUN/STOP** if not acquiring.

- e. Adjust trigger level (6) to trigger the waveform(s) selected or use these buttons (5) to either set a trigger level at the mid-amplitude level of the selected waveform or to force a single trigger. Example: Push **SET LEVEL TO 50%**.
3. Set all other functions using menus.
 - a. Choose the waveform source (8) first if setting a vertical function; else skip to step b. Example: Push **CH 2**.
 - b. Push **SHIFT** (4) if the function to be set is highlighted in blue; else skip to step c.

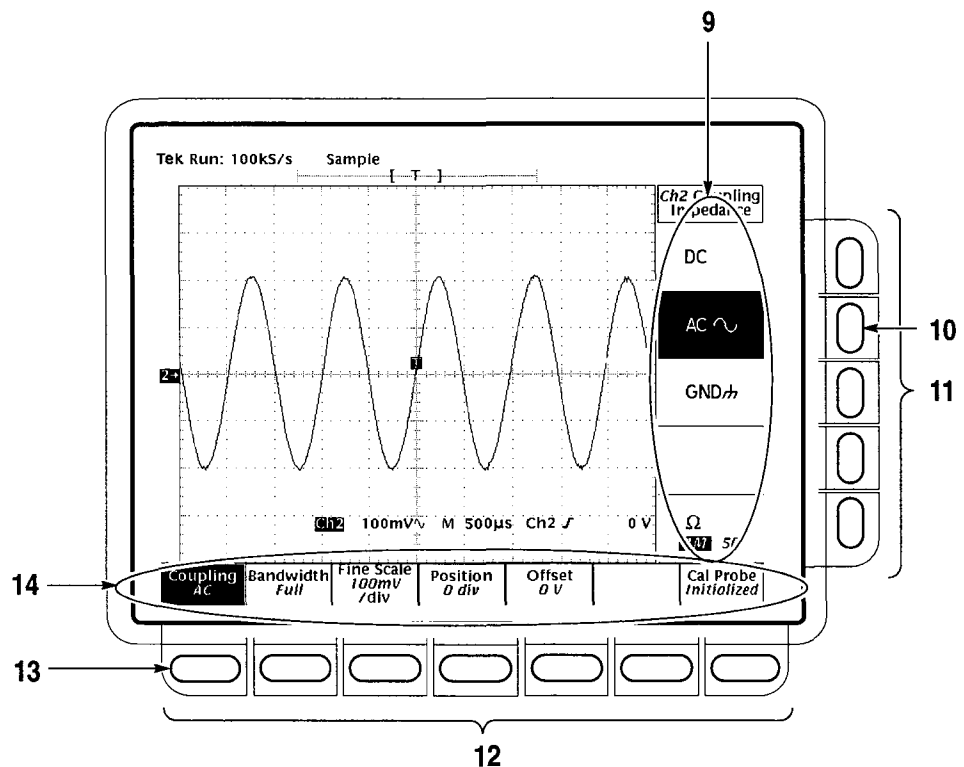

- c. Push the front-panel button that corresponds to the menu containing the function. A main menu (14) for selecting among related functions appears. Example: Push **VERTICAL MENU**.

Note the two labels: the top label is a function to choose from; the bottom label tells you the current setting for that function. **Offset** is currently set to **0 V**.

- d. Select a function from the main menu using the main-menu buttons (12). A side menu for selecting among that the available settings for that function appears. Example: Push **Coupling** (13).

- e. Select the setting for the function from the side menu (9) using the side-menu buttons (11). Example: Push AC (10).

How to Set Complex Functions

A few functions require more than just two levels (main and side) of menus to completely specify their settings. In such cases, either the main menu, the side menu, or both are modified to supply additional choices. The procedures that follow show both schemes.

1. Set up a function using pop-up menus:

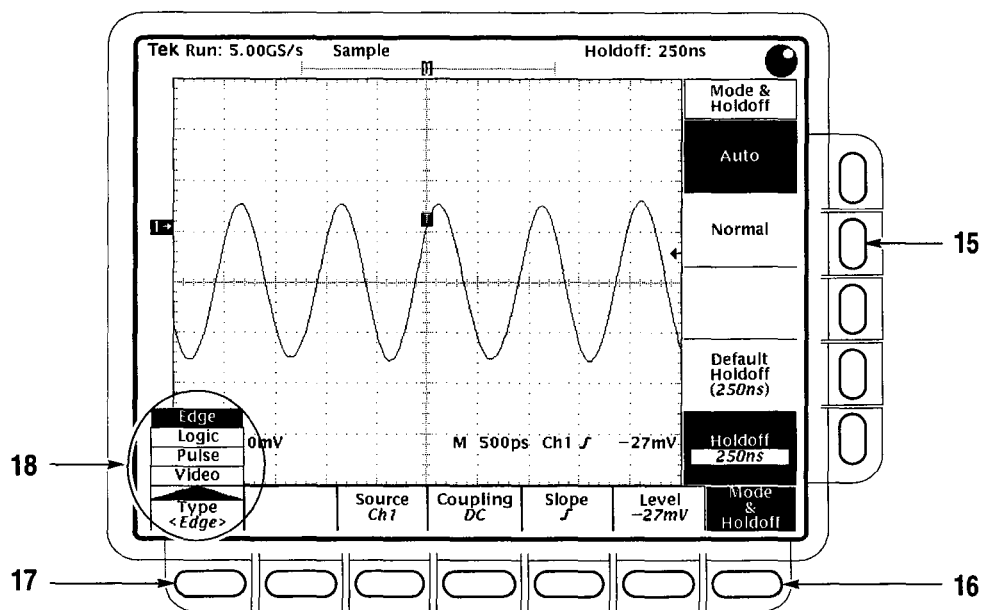

- a. For some selections, pushing a main-menu button pops up a menu (18) of subfunctions. Example: Push **Type** (17).

Note the pop-up menu for **Type** is set to **Edge**. All the main-menu buttons to the right of the pop-up menu are labeled with subfunctions of **Edge**.

- b. Pushing the button that popped up the menu (17) toggles through the pop-up menu choices. Example: Repeatedly push **Type** to toggle through the pop-up menu. Notice the other main-menu button labels change accordingly. Toggle back to **Edge**.
- c. Complete the setting of the desired mode by selecting from the main menu and the side menu that results. Example: Push **Mode & Holdoff** (16), and then push **Normal** (15).

2. Set up a function using the general purpose knob (20). (The examples of possible menu selections in the substeps that follow assume you've pushed **TRIGGER MENU**.)

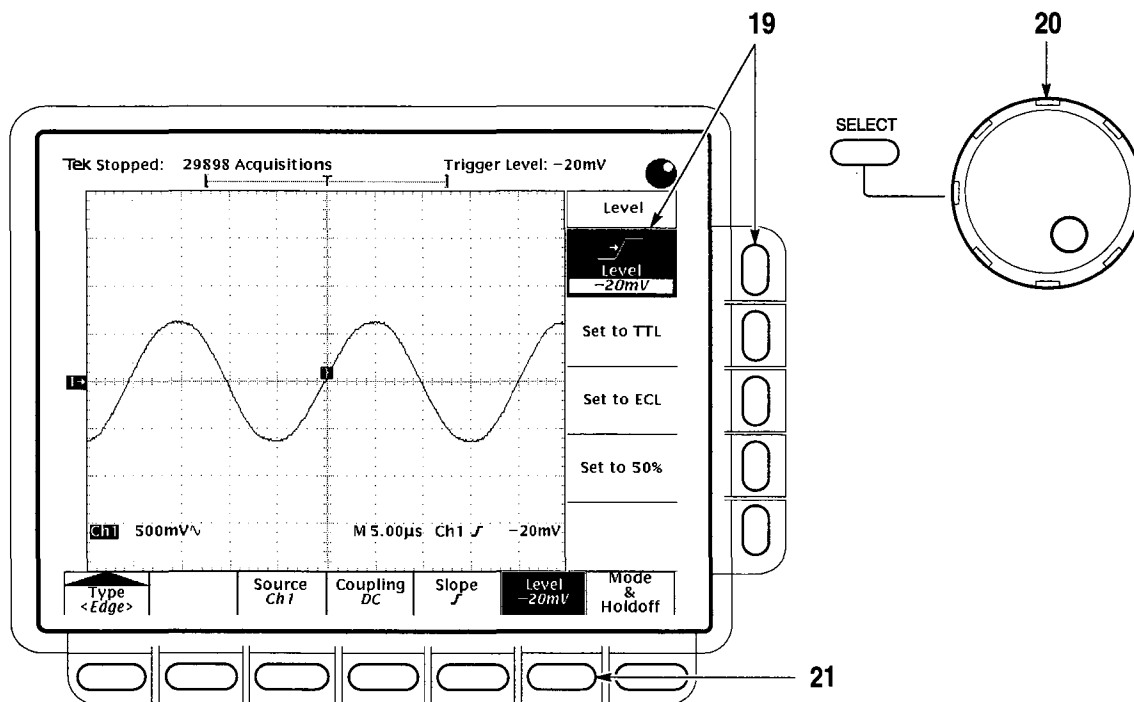

- a. Pushing some main-menu buttons displays a side menu with labels containing readouts that can be varied. Example: Push **Level** (21).
- b. Pushing the side-menu button **Level** assigns the general purpose knob to control the readout appearing in the button label. It also copies the readout to the general purpose knob readout area in the right corner of the screen. Example: Push **Level** (19).
- c. Use the general purpose knob (20) to adjust the trigger level to the setting desired. Example: Turn the knob to **-20 mV**.

More About the General Purpose Knob. As you've just seen, the general purpose knob can be used to extend the number of choices available to a side menu button. The general purpose knob can also be assigned to control the following functions:

- Cursor positioning
- Display intensities
- Delay time

- Gated measurements
- Number of events
- Template generation
- Trigger position
- Holdoff
- Offset
- Variable persistence

In all cases, the menus are used to select the function to which the general purpose knob is assigned. The following attributes apply to this knob:

- Depending on the function it is assigned to control, the general purpose knob may vary numerical readouts, position objects (cursors) on screen, or select between icon-label settings that show up in side-menu labels.
- The general purpose knob has a readout area at the upper right corner of the screen. (See Figure 2-1.) This readout always reflects the name and value of the function that the general purpose knob is currently controlling.
- Whenever the general purpose knob assignment is changed, a knob icon appears immediately to the left of the general purpose knob readout to notify you of the assignment change. The icon is removed as soon as you use the general purpose knob to change the value of the function it is assigned to.
- To assign the general purpose knob to control a function, display the menu containing the function; then select the function. (Note that not all functions can be controlled by the general purpose knob.)
- Whenever the menu is removed, the general purpose knob is not assigned and doesn't control any function. (An exception is the cursor function. If cursors are turned on, removing the menu leaves the knob assigned to control the cursors until reassigned by selecting another menu and function that uses the knob.)
- When the **SHIFT** button is lit, the general purpose knob becomes a coarse adjustment. When the **SHIFT** button is not lit, the general purpose knob becomes a fine adjustment.
- The general purpose knob also has a **SELECT** button. This button is used to toggle the knob between the control of either of the two cursors displayed when H-bar or V-bar cursors are turned on in the cursor menu.

Display and Utility Menus. Using the techniques described for using menus, you can access and change functions in the display menu and utilities menu. In the Display menu, you can set the following functions:

- Color: waveforms, readouts, graticule.
- Intensity: waveforms, readouts, graticule, etc.
- Style of waveform display(s): vectors or dots, intensified or non-intensified samples, and infinite or variable persistence.
- Display format: XY or YT.
- Graticule format: type.
- Waveform interpolation filter and readout options.

From the Utility menu, you can configure the GPIB port (talk/listen, address, etc.) and access internal routines for self diagnostics and self compensation. Instructions for setting up communication over the GPIB are found in Section 5, *Adjustment Procedures*.

Operating Instructions

Theory of Operation

This section describes the electrical operation of the TDS 684A and 744 Digitizing Oscilloscopes using the major circuit blocks or modules.

This section has two main parts:

- Logic Conventions describes how logic functions are discussed and represented in this manual.
- Module Overview describes circuit operation from a functional-circuit block perspective.

Logic Conventions

The Digitizing Oscilloscopes contain many digital logic circuits. This manual refers to these circuits with standard logic symbols and terms. Unless otherwise stated, all logic functions are described using the positive-logic convention: the more positive of the two logic levels is the high (1) state, and the more negative level is the low (0) state. Signal states may also be described as “true” meaning their active state or “false” meaning their non-active state. The specific voltages that constitute a high or low state vary among the electronic devices.

Active-low signals are indicated by a tilde prefixed to the signal name (~RESET). Signal names are considered to be either active-high, active-low, or to have both active-high and active-low states.

Module Overview

This module overview describes the basic operation of each functional circuit block as shown in Figure 9-2.

General The TDS 684A and 744 Digitizing Oscilloscopes have four-channels. Each channel provides a calibrated vertical scale factor.

Input Signal Path A signal enters the oscilloscope through a probe connected to a BNC on the A10 Attenuator/Acquisition board.

Attenuators. Circuitry in the attenuator selects the input coupling, termination, and the attenuation factor. The processor system, by way of the acquisition system, controls the attenuators. For example, if 50 Ω input termination is

selected and the input is overloaded, the processor system switches the input to the 1 M Ω position.

Probe Coding Interface. Probe coding interface signals pass through the attenuator portion of the A10 Attenuator/Acquisition to the acquisition system, where they are sensed and controlled.

Acquisition System. The acquisition system amplifies the input signals, samples them, converts them to digital signals, and controls the acquisition process under direction of the processor system. The acquisition system includes the trigger, acquisition timing, and acquisition mode generation and control circuitry.

Voltage Controlled Oscillator (VCO). Master clocks for the acquisition system are generated by the circuitry on the A10 Acquisition board. The circuitry makes up a phased locked loop. The master clock is divided down by the A10 Acquisition circuitry under control of the processor system.

D1 Bus. The acquisition system passes the digital values representing the acquired waveform through the A14 D1 Bus to the A11 DRAM Processor/Display board. This happens after a waveform acquisition is complete if the digital signal processor in the processor system requests the waveform.

Processor System. The processor system contains a 68020 microprocessor that controls the entire instrument. It includes the firmware. It also includes a GPIB interface. You can reprogram the firmware from a remote controller using the GPIB and an external software package.

The processor also includes a digital signal processor. This signal processor processes each waveform as directed by the system processor. Waveforms and any text to be displayed are passed on to the display system. The A11 DRAM Processor/Display board contains both the processor and display systems.

Display System. Text and waveforms are processed by different parts of the display circuitry. The display system sends the text and waveform information to the tube assembly as a video signal. The display system also generates and sends vertical (VSYNC) and horizontal (HSYNC) sync signals to the tube assembly. A VGA-compatible video output is at the rear of the TDS 684A and 744.

Tube Assembly

All information (waveforms, text, graticules, and pictographs) is displayed by the A30/31/32 Display system. The A30 generates the high voltages necessary to drive the display tube. It also contains the video amplifier, horizontal oscillator, and the vertical and horizontal yoke driver circuitry.

Front Panel The processor system sends instructions to and receives information from the Front Panel Processor on the A12 Front Panel board. The Front Panel Processor reads the front-panel switches and potentiometers. Any changes in their settings are reported to the processor system. The Front Panel Processor also turns the LEDs on and off and generates the bell signal.

Front-panel menu switches are also read by the Front Panel Processor. The processor sends any changes in menu selections to the processor system. The **ON/STBY** switch is one of the menu switches. However, it is not read by the Front Panel Processor, but passes through the A12 Front Panel board and the A11 DRAM Processor/Display board to the low voltage power supply.

The front panel also generates the probe compensation signals **SIGNAL** and **GND**.

Rear Panel The **GPIB** connector provides access to stored waveforms, and allows external control of the oscilloscope.

You can make hardcopies on the GPIB, RS-232 and Centronics ports.

Low Voltage Power Supply The low voltage power supply is a switching power converter with active power factor control. It supplies power to all of the circuitry in the oscilloscope.

The principal **POWER** switch, located on the rear panel, controls all power to the oscilloscope including the Low Voltage Power Supply. The **ON/STBY** switch, located on the front panel, also controls all of the power to the oscilloscope except for part of the circuitry in the Low Voltage Power Supply.

The power supply sends a power fail (~PF) warning to the processor system if the power is going down.

Fan The fan provides forced air cooling for the oscilloscope. It connects to +25 V from the Low Voltage Power Supply by way of the A11 DRAM Processor/Display module.

Theory of Operation

Performance Verification Procedures

Two types of Performance Verification procedures can be performed on this product; *Brief Procedures* and *Performance Tests*. You may not need to perform all of these procedures, depending on what you want to accomplish.

- To rapidly confirm that the oscilloscope functions and was adjusted properly, just do the brief procedures under *Self Tests*, which begin on page 4–5.

Advantages: These procedures are quick to do, require no external equipment or signal sources, and perform extensive functional and accuracy testing to provide high confidence that the oscilloscope will perform properly. They can be used as a quick check before making a series of important measurements.

- To further check functionality, first do the *Self Tests* just mentioned; then do the brief procedures under *Functional Tests* that begin on page 4–7.

Advantages: These procedures require minimal additional time to perform, require no additional equipment other than a standard-accessory probe, and more completely test the internal hardware of the oscilloscope. They can be used to quickly determine if the oscilloscope is suitable for putting into service, such as when it is first received.

- If more extensive confirmation of performance is desired, do the *Performance Tests*, beginning on page 4–15, after doing the *Functional* and *Self Tests* just referenced.

Advantages: These procedures add direct checking of warranted specifications. They require more time to perform and suitable test equipment is required. (See *Equipment Required* beginning on page 4–16.)

If you are not familiar with operating this oscilloscope, read the *TDS 684A & 744 Reference* (070-8999-XX) or the *TDS 684A & 744 User Manual* (070-8991-XX). These contain instructions that will acquaint you with the use of the front-panel controls and the menu system.

Conventions

Throughout these procedures the following conventions apply:

- Each test procedure uses the following general format:

Title of Test

Equipment Required

Prerequisites

Procedure

- Each procedure consists of as many steps, substeps, and subparts as required to do the test. Steps, substeps, and subparts are sequenced as follows:

1. First Step

a. First Substep

- First Subpart
- Second Subpart

b. Second Substep

2. Second Step

- In steps and substeps, the lead-in statement in italics instructs you what to do, while the instructions that follow tell you how to do it, as in the example step below, “*Initialize the oscilloscope*” by doing “Press save/recall **SETUP**. Now, press the main-menu button...”.

Initialize the oscilloscope: Press save/recall **SETUP**. Now, press the main-menu button **Recall Factory Setup**; then the side-menu button **OK Confirm Factory Init**.

- Where instructed to use a front-panel button or knob, or select from a main or side menu, or verify a readout or status message, the name of the button or knob appears in boldface type: “press **SHIFT**; then **UTILITY**, press the main-menu button **System** until **Cal** is highlighted in the pop-up menu. Verify that the status message is *Pass* in the main menu under the **Voltage Reference** label.”

STOP. The symbol at the left is accompanied by information you must read to do the procedure properly.

- Refer to Figure 4–1: “Main menu” refers to the menu that labels the seven menu buttons under the display; “side menu” refers to the menu that labels

the five buttons to the right of the display. "Pop-up menu" refers to a menu that pops up when a main-menu button is pressed.

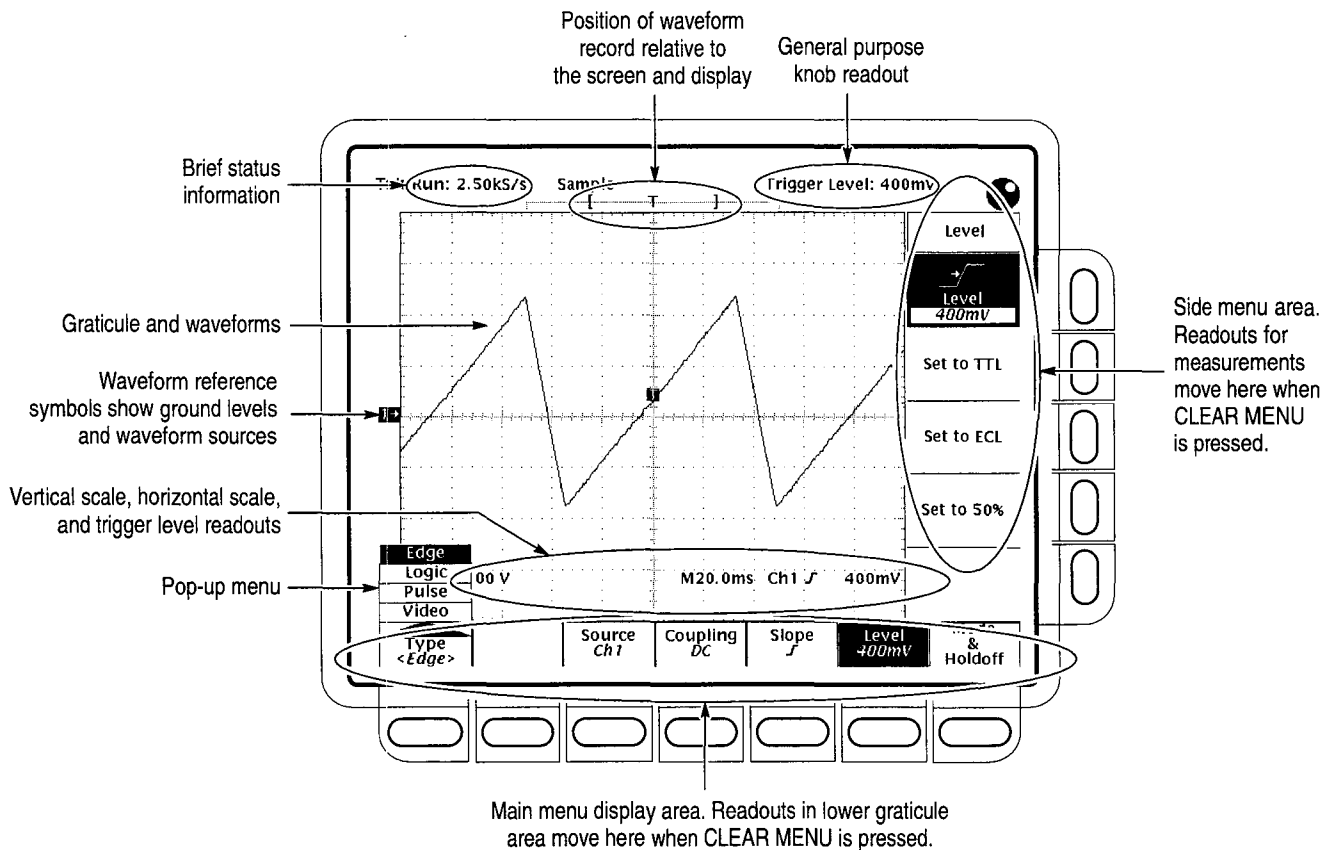

Figure 4-1: Map of Display Functions

Brief Procedures

The *Self Tests* use internal routines to confirm basic functionality and proper adjustment. No test equipment is required to do these test procedures.

The *Functional Tests* utilize the probe-compensation output at the front panel as a test-signal source for further verifying that the oscilloscope functions properly. An optional probe, such as the P6245, is the only extra equipment required.

Self Tests

This procedure uses internal routines to verify that the oscilloscope functions and was adjusted properly. No test equipment or hookups are required.

Verify Internal Adjustment, Self Compensation, and Diagnostics

Equipment Required	None
Prerequisites	Power on the Digitizing Oscilloscope and allow a 20 minute warm-up before doing this procedure.

1. *Verify that internal diagnostics pass:* Do the following substeps to verify passing of internal diagnostics.
 - a. *Display the System diagnostics menu:*
 - Press **SHIFT**; then press **UTILITY**.
 - Repeatedly press the main-menu button **System** until **Diag/Err** is highlighted in the pop-up menu.
 - b. *Run the System Diagnostics:*
 - First disconnect any input signals from all four channels.
 - Press the main-menu button **Execute**; then press the side-menu button **OK Confirm Run Test**.
 - c. *Wait:* The internal diagnostics do an exhaustive verification of proper oscilloscope function. This verification will take up to two minutes. At some time during the wait, a “clock” icon (shown at left) will appear on-screen. When the verification is finished, the resulting status will appear on the screen.
 - d. *Confirm no failures are found:* Verify that no failures are found and reported on-screen.



- e. *Confirm the three adjustment sections have passed status:*
 - Press **SHIFT**; then press **UTILITY**.
 - Highlight **Cal** in the pop-up menu by repeatedly pressing the main-menu button **System**. See Figure 4-2.
 - Verify that the word *Pass* appears in the main menu under the following menu labels: **Voltage Reference**, **Frequency Response**, and **Pulse Trigger**. See Figure 4-2.
- f. *Run the signal-path compensation:* Press the main-menu button **Signal Path**; then press the side-menu button **OK Compensate Signal Paths**.
- g. *Wait:* Signal-path compensation may take fifteen minutes to run. While it progresses, a “clock” icon (shown at left) is displayed on-screen. When compensation completes, the status message will be updated to *Pass* or *Fail* in the main menu. See step h.
- h. *Confirm signal-path compensation returns passed status:* Verify that the word *Pass* appears under **Signal Path** in the main menu. See Figure 4-2.

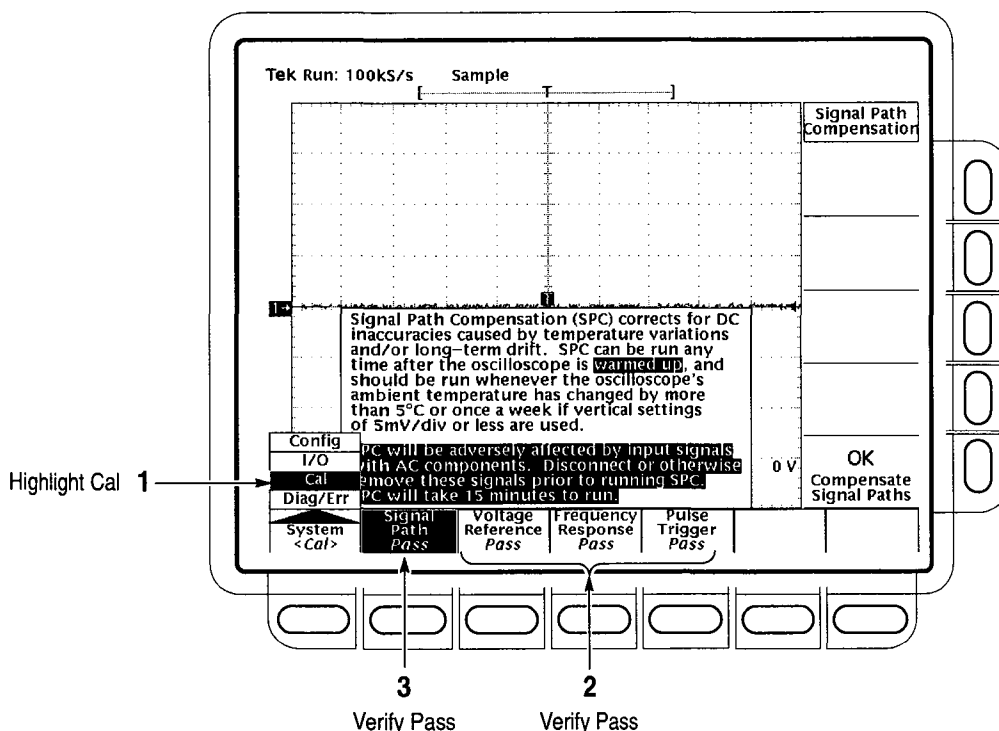

Figure 4-2: Verifying Adjustments and Signal-Path Compensation

2. *Return to regular service:* Press **CLEAR MENU** to exit the system menus.

Functional Tests

The purpose of these procedures is to confirm that the oscilloscope functions properly. The only equipment required is one of the standard-accessory probes and, to check the file system, a 3.5 inch, 720 K or 1.44 Mbyte floppy disk.



WARNING. *The optional P6245 probes that can be used with this oscilloscope provide an extremely low loading capacitance (<1 pF) to ensure the best possible signal reproduction. These probes should not be used to measure signals exceeding ± 8 volts, or errors in signal measurement will be observed. Above 40 volts, damage to the probe may result. To make measurements beyond ± 10 volts, use either the P6139A probe (good to 500 volts), or refer to the catalog for a recommended probe.*

STOP. *These procedures verify functions; that is, they verify that the oscilloscope features operate. They do not verify that they operate within limits.*

Therefore, when the instructions in the functional tests that follow call for you to verify that a signal appears on-screen “that is about five divisions in amplitude” or “has a period of about six horizontal divisions,” etc., do NOT interpret the quantities given as limits. Operation within limits is checked in Performance Tests, which begin on page 4–15.

STOP. *DO NOT make changes to the front-panel settings that are not called out in the procedures. Each verification procedure will require you to set the oscilloscope to certain default settings before verifying functions. If you make changes to these settings, other than those called out in the procedure, you may obtain invalid results. In this case, just redo the procedure from step 1.*

When you are instructed to press a menu button, the button may already be selected (its label will be highlighted). If this is the case, it is not necessary to press the button.

Verify All Input Channels

Equipment Required	One probe such as the P6245 or P6139A
Prerequisites	None

1. *Install the test hookup and preset the oscilloscope controls:*

- a. *Hook up the signal source:* Install the probe on **CH 1**. Connect the probe tip to **PROBE COMPENSATION SIGNAL** on the front panel; connect the probe ground (typically black) to **PROBE COMPENSATION GND**. If using a P6245 probe, you may want to attach a Y-lead connector and two SMD KlipChips as shown in Figure 4-3.

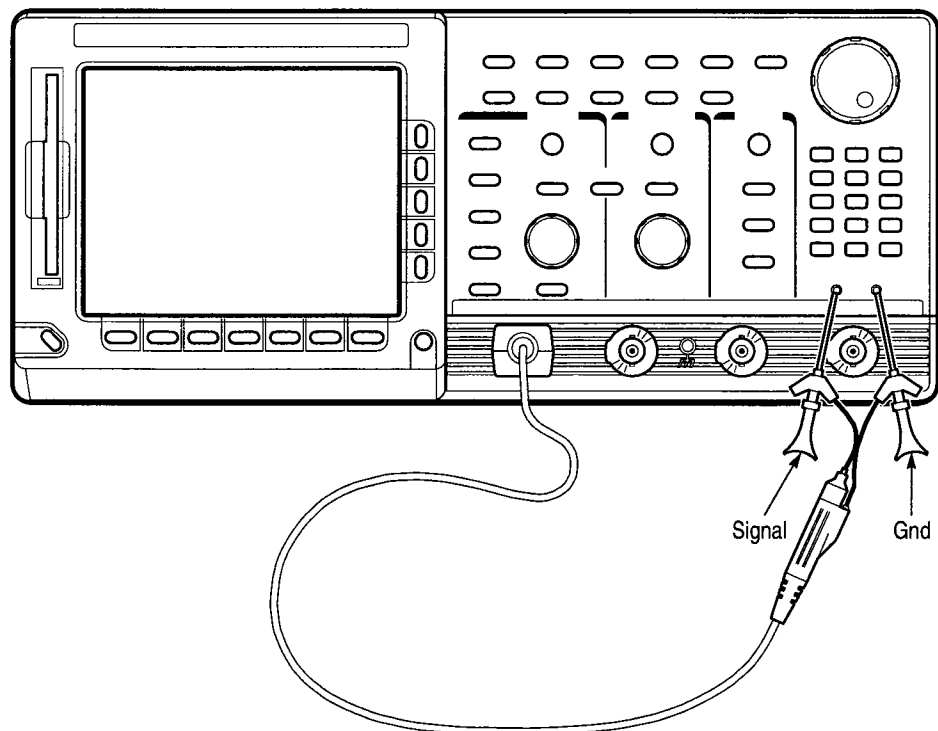

Figure 4-3: Universal Test Hookup for Functional Tests

b. *Initialize the oscilloscope:*

- Press save/recall **SETUP**.
- Press the main-menu button **Recall Factory Setup**.
- Press the side-menu button **OK Confirm Factory Init**.

2. *Verify that all channels operate:* Do the following substeps — test CH 1 first, *skipping substep a and b since CH 1 is already set up for verification and as the trigger source from step 1.*
 - a. *Select an unverified channel:*
 - Press **WAVEFORM OFF** to remove the channel just verified from display.
 - Press the front-panel button that corresponds to the channel you are to verify.
 - Move the probe to the channel you selected.
 - b. *Match the trigger source to the channel selected:*
 - Press **TRIGGER MENU**.
 - Press the main-menu button **Source**.
 - Press the side-menu button that corresponds to the channel selected (**Ch2**, **Ch3**, or **Ch4**).
 - c. *Set up the selected channel:*
 - Set the vertical **SCALE** to 200 mV.
 - Set the horizontal **SCALE** to 200 μ s. Press **CLEAR MENU** to remove any menu that may be on the screen.
 - d. *Verify that the channel is operational:* Confirm that the following statements are true.
 - The vertical scale readout for the channel under test shows a setting of 200 mV, and a square-wave probe-compensation signal about 2.5 divisions in amplitude is on-screen. See Figure 4-1 on page 4-3 to locate the readout.
 - The vertical **POSITION** knob moves the signal up and down the screen when rotated.
 - Turning the vertical **SCALE** knob counterclockwise decreases the amplitude of the waveform on-screen, turning the knob clockwise increases the amplitude, and returning the knob to 200 mV returns the amplitude to about 2.5 divisions.
 - e. *Verify that the channel acquires in all acquisition modes:* Press **SHIFT**; then press **ACQUIRE MENU**. Use the side menu to select, in turn, each of the three hardware acquire modes and confirm that the following statements are true. Refer to the icons at the left of each statement as you confirm those statements.

Brief Procedures



- Sample mode displays an actively acquiring waveform on-screen. (Note that there is noise present on the peaks of the square wave.)



- Peak Detect mode (TDS 744 only) displays an actively acquiring waveform on-screen with the noise present in Sample mode “peak detected.”



- Hi Res mode (TDS 744 only) displays an actively acquiring waveform on-screen with the noise that was present in Sample mode reduced.



- Envelope mode displays an actively acquiring waveform on-screen with the noise displayed.



- Average mode displays an actively acquiring waveform on-screen with the noise reduced.

f. *Test all channels:* Repeat substeps a through e until all four input channels are verified.

3. *Remove the test hookup:* Disconnect the probe from the channel input and the probe-compensation terminals.

Verify the Time Base

Equipment Required	One probe such as the P6245 or P6139A
Prerequisites	None

1. *Install the test hookup and preset the oscilloscope controls:*

a. *Hook up the signal source:* Install the probe on **CH 1**. Connect the probe tip to **PROBE COMPENSATION SIGNAL** on the front panel; connect the probe ground to **PROBE COMPENSATION GND**. See Figure 4-3 on page 4-8.

b. *Initialize the oscilloscope:*

- Press save/recall **SETUP**.
- Press the main-menu button **Recall Factory Setup**; then press the side-menu button **OK Confirm Factory Init**.

c. *Modify default settings:*

- Set the vertical **SCALE** to 200 mV.
- Set the horizontal **SCALE** to 200 μ s.
- Press **CLEAR MENU** to remove the menus from the screen.

2. *Verify that the time base operates:* Confirm the following statements.

- a. One period of the square-wave probe-compensation signal is about five horizontal divisions on-screen for the 200 μ s horizontal scale setting (set in step 1c).
 - b. Rotating the horizontal **SCALE** knob clockwise expands the waveform on-screen (more horizontal divisions per waveform period), counter-clockwise rotation contracts it, and returning the horizontal scale to 200 μ s returns the period to about five divisions.
 - c. The horizontal **POSITION** knob positions the signal left and right on-screen when rotated.
3. *Remove the test hookup:* Disconnect the probe from the channel input and the probe-compensation terminals.

Verify the Main and Delayed Trigger Systems

Equipment Required	One probe such as the P6245 or P6139A
Prerequisites	None

1. *Install the test hookup and preset the oscilloscope controls:*
 - a. *Hook up the signal source:* Install the probe on **CH 1**. Connect the probe tip to **PROBE COMPENSATION SIGNAL** on the front panel; connect the probe ground to **PROBE COMPENSATION GND**. See Figure 4-3 on page 4-8.
 - b. *Initialize the oscilloscope:*
 - Press save/recall **SETUP**.
 - Press the main-menu button **Recall Factory Setup**.
 - Press the side-menu button **OK Confirm Factory Init**.
 - c. *Modify default settings:*
 - Set the vertical **SCALE** to 200 mV.
 - Set the horizontal **SCALE** for the **M** (main) time base to 200 μ s.
 - Press **TRIGGER MENU**.
 - Press the main-menu button **Mode & Holdoff**.
 - Press the side-menu button **Normal**.
 - Press **CLEAR MENU** to remove the menus from the screen.

2. *Verify that the main trigger system operates:* Confirm that the following statements are true.
 - The trigger level readout for the main trigger system changes with the trigger-**LEVEL** knob.
 - The trigger-level knob can trigger and untrigger the square-wave signal as you rotate it. (Leave the signal *untriggered*, which is indicated by the display not updating.)
 - Pressing **SET LEVEL TO 50%** triggers the signal that you just left untriggered. (Leave the signal triggered.)
3. *Verify that the delayed trigger system operates:*
 - a. *Select the delayed time base:*
 - Press **HORIZONTAL MENU**.
 - Press the main-menu button **Time Base**.
 - Press the side-menu button **Delayed Triggerable**; then press the side-menu button **Delayed Only**.
 - Set the horizontal **SCALE** for the **D** (delayed) time base to 200 μ s.
 - b. *Select the delayed trigger level menu:*
 - Press **SHIFT**; then press **DELAYED TRIG**.
 - Press the main-menu button **Level**; then press the side-menu button **Level**.
 - c. *Confirm that the following statements are true:*
 - The trigger-level readout for the delayed trigger system changes as you turn the general purpose knob.
 - As you rotate the general purpose knob, the square-wave probe-compensation signal can become triggered and untriggered. (Leave the signal *untriggered*, which is indicated by the display not updating.)
 - Pressing the side-menu button **Set to 50%** triggers the probe-compensation signal that you just left untriggered. (Leave the signal triggered.)
 - d. *Verify the delayed trigger counter:*
 - Press the main-menu button **Delay by Time**.
 - Use the keypad to enter a delay time of 1 second. Press **1**, then press **ENTER**.

- Verify that the trigger **READY** indicator on the front panel flashes about once every second as the waveform is updated on-screen.
4. *Remove the test hookup:* Disconnect the probe from the channel input and the probe-compensation terminals.

Verify the File System

Equipment Required	One probe such as the P6245 or P6139A One 720 K or 1.44 Mbyte, 3.5 inch DOS-compatible disk. You can use a disk of your own or you can use the Programming Examples Software 3.5 inch disk (Tektronix part number 063-1134-XX) contained in the TDS Family Programmer Manual (Tektronix part number 070-8709-XX).
Prerequisites	None

1. *Install the test hookup and preset the oscilloscope controls:*
 - a. *Hook up the signal source:* Install the probe on **CH 1**. Connect the probe tip to **PROBE COMPENSATION SIGNAL** on the front panel; connect the probe ground to **PROBE COMPENSATION GND**. See Figure 4-3 on page 4-8.
 - b. *Insert the test disk:* Insert the disk in the disk drive to the left of the monitor.
 - Position the disk so the metal shutter faces the drive.
 - Position the disk so the stamped arrow is on the top right side. In other words, place the angled corner in the front bottom location.
 - Push the disk into the drive until it goes all the way in and clicks into place.
 - c. *Initialize the oscilloscope:*
 - Press save/recall **SETUP**.
 - Press the main-menu button **Recall Factory Setup**.
 - Press the side-menu button **OK Confirm Factory Init**.
 - d. *Modify default settings:*
 - Set the vertical **SCALE** to 200 mV.
 - Set the horizontal **SCALE** for the **M** (main) time base to 200 μ s. Notice the waveform on the display now shows two cycles instead of five.
 - Press **CLEAR MENU** to remove the menus from the screen.

- e. *Save the settings:*
 - Press **SETUP**.
 - Press the main-menu button **Save Current Setup**; then press the side-menu button **To File**.
 - Turn the general purpose knob to select the file to save. Choose **TEK?????.SET** (or **fdo:**). With this choice, you will save a file starting with **TEK**, then containing 5-numbers, and a **.SET** extension. For example, the first time you run this on a blank, formatted disk or on the Example Programs Disk, the oscilloscope will assign the name **TEK00000.SET** to your file. If you ran the procedure again, the oscilloscope would increment the name and call the file **TEK00001.SET**.
 - Press the side-menu button **Save To Selected File**.
2. *Verify the file system works:*
 - Press the main-menu button **Recall Factory Setup** and the side-menu button **OK Confirm Factory Init** to restore the 500 μ s time base and the five cycle waveform.
 - Press the main-menu button **Recall Saved Setup**; then press the side-menu button **From File**.
 - Turn the general purpose knob to select the file to recall. For example, if you followed the instructions above and used a blank disk, you had the oscilloscope assign the name **TEK00000.SET** to your file.
 - Press the side-menu button **Recall From Selected File**.
 - Verify that Digitizing Oscilloscope retrieved the saved setup from the disk. Do this by noticing the horizontal **SCALE** for the **M** (main) time base is again 200 μ s and the waveform shows only two cycles just as it was when you saved the setup.
3. *Remove the test hookup:*
 - Disconnect the probe from the channel input and the probe-compensation terminals.
 - Remove the disk from the disk drive. Do this by pushing in the tab at the bottom of the disk drive.

Performance Tests

This section contains a collection of procedures for checking that the TDS 684A and 744 Digitizing Oscilloscopes perform as warranted.

The procedures are arranged in four logical groupings: *Signal Acquisition System Checks*, *Time Base System Checks*, *Triggering System Checks*, and *Output Ports Checks*. They check all the characteristics that are designated as checked in *Specifications*. (The characteristics that are checked appear in **boldface** type under *Warranted Characteristics* in *Specifications*.)

STOP. *These procedures extend the confidence level provided by the basic procedures described on page 4–5. The basic procedures should be done first, then these procedures performed if desired.*

Prerequisites

The tests in this section comprise an extensive, valid confirmation of performance and functionality when the following requirements are met:

- The cabinet must be installed on the Digitizing Oscilloscope.
- You must have performed and passed the procedures under *Self Tests*, found on page 4–5, and those under *Functional Tests*, found on page 4–7.
- A signal-path compensation must have been done within the recommended calibration interval and at a temperature within $\pm 5^{\circ}$ C of the present operating temperature. (If at the time you did the prerequisite *Self Tests*, the temperature was within the limits just stated, consider this prerequisite met.)
- The Digitizing Oscilloscope must have been last adjusted at an ambient temperature between $+20^{\circ}$ C and $+30^{\circ}$ C, must have been operating for a warm-up period of at least 20 minutes, and must be operating at an ambient temperature between $+4^{\circ}$ C and either $+45^{\circ}$ C for the TDS 684A or $+50^{\circ}$ C for the TDS 744. (The warm-up requirement is usually met in the course of meeting the first prerequisite listed above.)

Equipment Required

These procedures use external, traceable signal sources to directly check warranted characteristics. The required equipment list follows this introduction.

Table 4-1: Test Equipment

Item Number and Description	Minimum Requirements	Example	Purpose
1. Attenuator, 10X (two required)	Ratio: 10X; impedance 50 Ω ; connectors: female BNC input, male BNC output	Tektronix part number 011-0059-02	Signal Attenuation
2. Attenuator, 5X	Ratio: 5X; impedance 50 Ω ; connectors: female BNC input, male BNC output	Tektronix part number 011-0060-02	Signal Attenuation
3. Adapter, BNC female to Clip Leads	BNC female to Clip Leads	Tektronix part number 013-0076-00	Signal Coupling for Probe Compensator Output Check
4. Terminator, 50 Ω	Impedance 50 Ω ; connectors: female BNC input, male BNC output	Tektronix part number 011-0049-01	Signal Termination for Channel Delay Test
5. Cable, Precision 50 Ω Coaxial (two required)	50 Ω , 36 in, male to male BNC connectors	Tektronix part number 012-0482-00	Signal Interconnection
6. Connector, Dual-Banana (two required)	Female BNC to dual banana	Tektronix part number 103-0090-00	Various Accuracy Tests
7. Connector, BNC "T"	Male BNC to dual female BNC	Tektronix part number 103-0030-00	Checking Trigger Sensitivity
8. Coupler, Dual-Input	Female BNC to dual male BNC	Tektronix part number 067-0525-02	Checking Delay Between Channels
9. Generator, DC Calibration	Variable amplitude to ± 104 V; accuracy to 0.1%	Data Precision 8200	Checking DC Offset, Gain, and Measurement Accuracy
10. Generator, Calibration	500 mV square wave calibrator amplitude; accuracy to 0.25%	Tektronix PG 506A ¹	To check accuracy of CH 3 Signal Out
11. Generator, Leveled Sine Wave, Medium-Frequency	200 kHz to 250 MHz; Variable amplitude from 5 mV to 4 V _{p-p} into 50 Ω	Tektronix SG 503 Leveled Sine Wave Generator ¹	Checking Trigger Sensitivity at low frequencies
12. Generator, Leveled Sine Wave, High-Frequency	250 MHz to 1 GHz; Variable amplitude from 500 mV to 4 V _{p-p} into 50 Ω ; 6 MHz reference	Tektronix SG 504 Leveled Sine Wave Generator ¹ with SG 504 Output Head	Checking Analog Bandwidth and Trigger Sensitivity at high frequencies
13. Generator, Time Mark	Variable marker frequency from 10 ms to 10 ns; accuracy within 2 ppm	Tektronix TG 501A Time Mark Generator ¹	Checking Sample-Rate and Delay-time Accuracy
14. Probe, 10X	A P6139A or P6245 probe ²	Tektronix part number P6139A or P6245	Signal Interconnection

Table 4-1: Test Equipment (Cont.)

Item Number and Description	Minimum Requirements	Example	Purpose
15. 3.5 inch, 720 K or 1.44 Mbyte, DOS-compatible floppy disk		Programming Examples Software Disk (Tektronix part number 063-1134-XX) that comes with the TDS Family Programmer Manual (Tektronix part number 070-8709-XX)	Checking File System Basic Functionality
16. Generator, Video Signal	Provides PAL compatible outputs	Tektronix TSG 121	Used to Test Video Option 05 Equipped Instruments Only
17. Oscillator, Leveled Sine wave Generator	60 Hz. Sine wave	Tektronix part number SG 502	Used to Test Video Option 05 Equipped Instruments Only
18. Pulse Generator		Tektronix part number PG 502	Used to Test Video Option 05 Equipped Instruments Only
19. Cable, Coaxial (two required)	75 Ω , 36 in, male to male BNC connectors	Tektronix part number 012-1338-00	Used to Test Video Option 05 Equipped Instruments Only
20. Terminator, 75 Ω (two required)	Impedance 75 Ω ; connectors: female BNC input, male BNC output	Tektronix part number 011-0102-01	Used to Test Video Option 05 Equipped Instruments Only

¹ Requires a TM 500 or TM 5000 Series Power Module Mainframe.

² **Warning:** The optional P6245 probes that may be used with this oscilloscope provide an extremely low loading capacitance (<1 pF) to ensure the best possible signal reproduction. These probes should not be used to measure signals exceeding ± 8 V, or errors in signal measurement will be observed. Above 40 V, damage to the probe may result. To make measurements beyond ± 8 V, use either the P6139A probe (good to 500 V), or refer to the catalog for a recommended probe.

Performance Tests



TDS 684A Test Record

Photocopy this and the next three pages and use them to record the performance test results for your TDS 684A.

TDS 684A Test Record

Instrument Serial Number: _____ Certificate Number: _____
 Temperature: _____ RH %: _____
 Date of Calibration: _____ Technician: _____

TDS 684A Performance Test		Minimum	Incoming	Outgoing	Maximum
Offset Accuracy					
CH1 Offset	+1 mV	- 1.45 mV	_____	_____	+ 1.45 mV
	+101 mV	- 69.1 mV	_____	_____	+ 69.1 mV
	+1.01 V	- 691 mV	_____	_____	+ 691 mV
CH2 Offset	+1 mV	- 1.45 mV	_____	_____	+ 1.45 mV
	+101 mV	- 69.1 mV	_____	_____	+ 69.1 mV
	+1.01 V	- 691 mV	_____	_____	+ 691 mV
CH3 Offset	+1 mV	- 1.45 mV	_____	_____	+ 1.45 mV
	+101 mV	- 69.1 mV	_____	_____	+ 69.1 mV
	+1.01 V	- 691 mV	_____	_____	+ 691 mV
CH4 Offset	+1 mV	- 1.45 mV	_____	_____	+ 1.45 mV
	+101 mV	- 69.1 mV	_____	_____	+ 69.1 mV
	+1.01 V	- 691 mV	_____	_____	+ 691 mV
DC Voltage Measurement Accuracy (Averaged)					
CH1	5 mV Vert scale setting, -5 Div position setting, +1 V offset	+ 1.029 V	_____	_____	+ 1.0513 V
CH1	5 mV Vert scale setting, +5 Div position setting, -1 V offset	- 1.0513 V	_____	_____	- 1.029 V
CH1	200 mV Vert scale setting, -5 Div position setting, +10 V offset	+ 11.420 V	_____	_____	+ 11.786 V
CH1	200 mV Vert scale setting, +5 Div position setting, -10 V offset	- 11.786 V	_____	_____	- 11.420 V
CH1	1 V Vert scale setting, -5 Div position setting, +10 V offset	+ 17.26 V	_____	_____	+ 18.76 V
CH1	1 V Vert scale setting, +5 Div position setting, -10 V offset	- 18.76 V	_____	_____	- 17.26 V
CH2	5 mV Vert scale setting, -5 Div position setting, +1 V offset	+ 1.029 V	_____	_____	+ 1.0513 V
CH2	5 mV Vert scale setting, +5 Div position setting, -1 V offset	- 1.0513 V	_____	_____	- 1.029 V
CH2	200 mV Vert scale setting, -5 Div position setting, +10 V offset	+ 11.420 V	_____	_____	+ 11.786 V

Performance Tests

TDS 684A Test Record (Cont.)

Instrument Serial Number: _____ Certificate Number: _____
 Temperature: _____ RH %: _____
 Date of Calibration: _____ Technician: _____

TDS 684A Performance Test		Minimum	Incoming	Outgoing	Maximum
CH2	200 mV Vert scale setting, +5 Div position setting, -10 V offset	- 11.786 V	_____	_____	- 11.420 V
CH2	1 V Vert scale setting, -5 Div position setting, +10 V offset	+ 17.26 V	_____	_____	+ 18.76 V
CH2	1 V Vert scale setting, +5 Div position setting, -10 V offset	- 18.76 V	_____	_____	- 17.26 V
CH3	5 mV Vert scale setting, -5 Div position setting, +1 V offset	+ 1.029 V	_____	_____	+ 1.0513 V
CH3	5 mV Vert scale setting, +5 Div position setting, -1 V offset	- 1.0513 V	_____	_____	- 1.029 V
CH3	200 mV Vert scale setting, -5 Div position setting, +10 V offset	+ 11.420 V	_____	_____	+ 11.786 V
CH3	200 mV Vert scale setting, +5 Div position setting, -10 V offset	- 11.786 V	_____	_____	- 11.420 V
CH3	1 V Vert scale setting, -5 Div position setting, +10 V offset	+ 17.26 V	_____	_____	+ 18.76 V
CH3	1 V Vert scale setting, +5 Div position setting, -10 V offset	- 18.76 V	_____	_____	- 17.26 V
CH4	5 mV Vert scale setting, -5 Div position setting, +1 V offset	+ 1.029 V	_____	_____	+ 1.0513 V
CH4	5 mV Vert scale setting, +5 Div position setting, -1 V offset	- 1.0513 V	_____	_____	- 1.029 V
CH4	200 mV Vert scale setting, -5 Div position setting, +10 V offset	+ 11.420 V	_____	_____	+ 11.786 V
CH4	200 mV Vert scale setting, +5 Div position setting, -10 V offset	- 11.786 V	_____	_____	- 11.420 V
CH4	1 V Vert scale setting, -5 Div position setting, +10 V offset	+ 17.26 V	_____	_____	+ 18.76 V
CH4	1 V Vert scale setting, +5 Div position setting, -10 V offset	- 18.76 V	_____	_____	- 17.26 V

Analog Bandwidth

CH1	100 mV	424 mV	_____	_____	N/A
CH2	100 mV	424 mV	_____	_____	N/A
CH3	100 mV	424 mV	_____	_____	N/A
CH4	100 mV	424 mV	_____	_____	N/A

TDS 684A Test Record (Cont.)

Instrument Serial Number: _____ Certificate Number: _____
 Temperature: _____ RH %: _____
 Date of Calibration: _____ Technician: _____

TDS 684A Performance Test	Minimum	Incoming	Outgoing	Maximum
Delay Between Channels				
Delay Between Channels	N/A	_____	_____	100 ps
Time Base System				
Long Term Sample Rate/ Delay Time @ 500 ns/10 ms	-2.0 Div	_____	_____	+2.0 Div
Trigger System Accuracy				
Pulse-Glitch or Pulse-Width, Hor. scale $\leq 1 \mu\text{s}$				
Lower Limit	2.5 ns	_____	_____	7.5 ns
Upper Limit	2.5 ns	_____	_____	7.5 ns
Pulse-Glitch or Pulse-Width, Hor. scale $> 1 \mu\text{s}$				
Lower Limit	1 μs	_____	_____	3 μs
Upper Limit	1 μs	_____	_____	3 μs
Main Trigger, DC Coupled, Positive Slope	9.863 V	_____	_____	10.137 V
Main Trigger, DC Coupled, Negative Slope	9.863 V	_____	_____	10.137 V
Delayed Trigger, DC Coupled, Positive Slope	9.863 V	_____	_____	10.137 V
Delayed Trigger, DC Coupled, Negative Slope	9.863 V	_____	_____	10.137 V
CH1 Sensitivity, 50 MHz, Main	Pass/Fail	_____	_____	Pass/Fail
CH1 Sensitivity, 50 MHz, Delayed	Pass/Fail	_____	_____	Pass/Fail
CH1 AUX Trigger Input	Pass/Fail	_____	_____	Pass/Fail
CH1 Sensitivity, 1 GHz, Main	Pass/Fail	_____	_____	Pass/Fail
CH1 Sensitivity, 1 GHz, Delayed	Pass/Fail	_____	_____	Pass/Fail
Output Signal Checks				
MAIN TRIGGER OUTPUT, 1 M Ω				
High	High $\geq 2.5 \text{ V}$	_____	_____	
Low		_____	_____	Low $\leq 0.7 \text{ V}$
MAIN TRIGGER OUTPUT, 50 Ω				
High	High $\geq 1.0 \text{ V}$	_____	_____	
Low		_____	_____	Low $\leq 0.25 \text{ V}$
DELAYED TRIGGER OUTPUT, 50 Ω				
High	High $\geq 1.0 \text{ V}$	_____	_____	
Low		_____	_____	Low $\leq 0.25 \text{ V}$
DELAYED TRIGGER OUTPUT, 1 M Ω				
High	High $\geq 2.5 \text{ V}$	_____	_____	
Low		_____	_____	Low $\leq 0.7 \text{ V}$

Performance Tests

TDS 684A Test Record (Cont.)

Instrument Serial Number: _____ Certificate Number: _____
 Temperature: _____ RH %: _____
 Date of Calibration: _____ Technician: _____

TDS 684A Performance Test	Minimum	Incoming	Outgoing	Maximum
CH 3 SIGNAL OUTPUT, 1 MΩ	Pk-Pk ≥ 80 mV	_____	_____	Pk-Pk ≤ 120 mV
CH 3 SIGNAL OUTPUT, 50 Ω	Pk-Pk ≥ 40 mV	_____	_____	Pk-Pk ≤ 60 mV
Probe Compensator Output Signal				
Frequency (CH1 Freq.)	950 Hz	_____	_____	1.050 kHz
Voltage (difference)	495 mV	_____	_____	505 mV

TDS 744 Test Record

Photocopy this and the next three pages and use them to record the performance test results for your TDS 744.

TDS 744 Test Record

Instrument Serial Number: _____ Certificate Number: _____
 Temperature: _____ RH %: _____
 Date of Calibration: _____ Technician: _____

TDS 744 Performance Test		Minimum	Incoming	Outgoing	Maximum
Offset Accuracy					
CH1 Offset	+1 mV	-1.6 mV	_____	_____	+1.6 mV
	+101 mV	-25.1 mV	_____	_____	+25.1 mV
	+1.01 V	-251 mV	_____	_____	+251 mV
CH2 Offset	+1 mV	-1.6 mV	_____	_____	+1.6 mV
	+101 mV	-25.1 mV	_____	_____	+25.1 mV
	+1.01 V	-251 mV	_____	_____	+251 mV
CH3 Offset	+1 mV	-1.6 mV	_____	_____	+1.6 mV
	+101 mV	-25.1 mV	_____	_____	+25.1 mV
	+1.01 V	-251 mV	_____	_____	+251 mV
CH4 Offset	+1 mV	-1.6 mV	_____	_____	+1.6 mV
	+101 mV	-25.1 mV	_____	_____	+25.1 mV
	+1.01 V	-251 mV	_____	_____	+251 mV
DC Voltage Measurement Accuracy (Averaged)					
CH1	5 mV Vert scale setting, -5 Div position setting, +1 V offset	+ 1.0355 V	_____	_____	+ 1.0445 V
CH1	5 mV Vert scale setting, +5 Div position setting, -1 V offset	- 1.0445 V	_____	_____	- 1.0355 V
CH1	200 mV Vert scale setting, -5 Div position setting, +10 V offset	+ 11.5385 V	_____	_____	+ 11.6615 V
CH1	200 mV Vert scale setting, +5 Div position setting, -10 V offset	- 11.6615 V	_____	_____	- 11.5385 V
CH1	1 V Vert scale setting, -5 Div position setting, +10 V offset	+ 17.7785 V	_____	_____	+ 18.2215 V
CH1	1 V Vert scale setting, +5 Div position setting, -10 V offset	- 18.2215 V	_____	_____	- 17.7785 V
CH2	5 mV Vert scale setting, -5 Div position setting, +1 V offset	+ 1.0355 V	_____	_____	+ 1.0445 V
CH2	5 mV Vert scale setting, +5 Div position setting, -1 V offset	- 1.0445 V	_____	_____	- 1.0355 V
CH2	200 mV Vert scale setting, -5 Div position setting, +10 V offset	+ 11.5385 V	_____	_____	+ 11.6615 V

Performance Tests

TDS 744 Test Record (Cont.)

Instrument Serial Number: _____ Certificate Number: _____
 Temperature: _____ RH %: _____
 Date of Calibration: _____ Technician: _____

TDS 744 Performance Test		Minimum	Incoming	Outgoing	Maximum
CH2	200 mV Vert scale setting, +5 Div position setting, -10 V offset	- 11.6615 V	_____	_____	- 11.5385 V
CH2	1 V Vert scale setting, -5 Div position setting, +10 V offset	+ 17.7785 V	_____	_____	+ 18.2215 V
CH2	1 V Vert scale setting, +5 Div position setting, -10 V offset	- 18.2215 V	_____	_____	- 17.7785 V
CH3	5 mV Vert scale setting, -5 Div position setting, +1 V offset	+ 1.0355 V	_____	_____	+ 1.0445 V
CH3	5 mV Vert scale setting, +5 Div position setting, -1 V offset	- 1.0445 V	_____	_____	- 1.0355 V
CH3	200 mV Vert scale setting, -5 Div position setting, +10 V offset	+ 11.5385 V	_____	_____	+ 11.6615 V
CH3	200 mV Vert scale setting, +5 Div position setting, -10 V offset	- 11.6615 V	_____	_____	- 11.5385 V
CH3	1 V Vert scale setting, -5 Div position setting, +10 V offset	+ 17.7785 V	_____	_____	+ 18.2215 V
CH3	1 V Vert scale setting, +5 Div position setting, -10 V offset	- 18.2215 V	_____	_____	- 17.7785 V
CH4	5 mV Vert scale setting, -5 Div position setting, +1 V offset	+ 1.0355 V	_____	_____	+ 1.0445 V
CH4	5 mV Vert scale setting, +5 Div position setting, -1 V offset	- 1.0445 V	_____	_____	- 1.0355 V
CH4	200 mV Vert scale setting, -5 Div position setting, +10 V offset	+ 11.5385 V	_____	_____	+ 11.6615 V
CH4	200 mV Vert scale setting, +5 Div position setting, -10 V offset	- 11.6615 V	_____	_____	- 11.5385 V
CH4	1 V Vert scale setting, -5 Div position setting, +10 V offset	+ 17.7785 V	_____	_____	+ 18.2215 V
CH4	1 V Vert scale setting, +5 Div position setting, -10 V offset	- 18.2215 V	_____	_____	- 17.7785 V

Analog Bandwidth					
CH1	100 mV	424 mV	_____	_____	N/A
CH2	100 mV	424 mV	_____	_____	N/A
CH3	100 mV	424 mV	_____	_____	N/A
CH4	100 mV	424 mV	_____	_____	N/A

TDS 744 Test Record (Cont.)

Instrument Serial Number: _____ Certificate Number: _____
 Temperature: _____ RH %: _____
 Date of Calibration: _____ Technician: _____

TDS 744 Performance Test	Minimum	Incoming	Outgoing	Maximum
Delay Between Channels				
Delay Between Channels	N/A	_____	_____	100 ps
Time Base System				
Long Term Sample Rate/ Delay Time @ 100 ns/10.0015 ms for TDS 744 with serial number B019999 and below or Delay Time @ 100 ns/10.0 ms for TDS 744 with serial number B020000 and above or for TDS 684A	-2.5 Div	_____	_____	+2.5 Div
Trigger System Accuracy				
Pulse-Glitch or Pulse-Width, Hor. scale $\leq 1 \mu\text{s}$				
Lower Limit	3.5 ns	_____	_____	6.5 ns
Upper Limit	2.5 ns	_____	_____	6.5 ns
Pulse-Glitch or Pulse-Width, Hor. scale $> 1 \mu\text{s}$				
Lower Limit	1.9 μs	_____	_____	2.1 μs
Upper Limit	1.9 μs	_____	_____	2.1 μs
Main Trigger, DC Coupled, Positive Slope	9.9393 V	_____	_____	10.1147 V
Main Trigger, DC Coupled, Negative Slope	9.9393 V	_____	_____	10.1147 V
Delayed Trigger, DC Coupled, Positive Slope	9.9393 V	_____	_____	10.1147 V
Delayed Trigger, DC Coupled, Negative Slope	9.9393 V	_____	_____	10.1147 V
CH1 Sensitivity, 50 MHz, Main	Pass/Fail	_____	_____	Pass/Fail
CH1 Sensitivity, 50 MHz, Delayed	Pass/Fail	_____	_____	Pass/Fail
CH1 AUX Trigger Input	Pass/Fail	_____	_____	Pass/Fail
CH1 Sensitivity, 500 MHz, Main	Pass/Fail	_____	_____	Pass/Fail
CH1 Sensitivity, 500 MHz, Delayed	Pass/Fail	_____	_____	Pass/Fail
Output Signal Checks				
MAIN TRIGGER OUTPUT, 1 M Ω				
High	High $\geq 2.5 \text{ V}$	_____	_____	Low $\leq 0.7 \text{ V}$
Low		_____	_____	
MAIN TRIGGER OUTPUT, 50 Ω				
High	High $\geq 1.0 \text{ V}$	_____	_____	Low $\leq 0.25 \text{ V}$
Low		_____	_____	

Performance Tests

TDS 744 Test Record (Cont.)

Instrument Serial Number: _____ Certificate Number: _____
 Temperature: _____ RH %: _____
 Date of Calibration: _____ Technician: _____

TDS 744 Performance Test	Minimum	Incoming	Outgoing	Maximum
DELAYED TRIGGER OUTPUT, 50 Ω High Low	High ≥ 1.0 V	_____	_____	Low ≤ 0.25 V
DELAYED TRIGGER OUTPUT, 1 M Ω High Low	High ≥ 2.5 V	_____	_____	Low ≤ 0.7 V
CH 3 SIGNAL OUTPUT, 1 M Ω	Pk-Pk ≥ 88 mV	_____	_____	Pk-Pk ≤ 132 mV
CH 3 SIGNAL OUTPUT, 50 Ω	Pk-Pk ≥ 44 mV	_____	_____	Pk-Pk ≤ 66 mV
Probe Compensator Output Signal				
Frequency (CH1 Freq.)	950 Hz	_____	_____	1.050 kHz
Voltage (difference)	495 mV	_____	_____	505 mV

Signal Acquisition System Checks

These procedures check those characteristics that relate to the signal-acquisition system and are listed as checked under *Warranted Characteristics* in *Specifications*.

Check Offset Accuracy (Zero Setting)

Equipment Required	None
Prerequisites	The oscilloscope must meet the prerequisites listed on page 4-15

1. *Preset the instrument controls:*
 - a. *Initialize the oscilloscope:*
 - Press save/recall **SETUP**.
 - Press the main-menu button **Recall Factory Setup**.
 - Press the side-menu button **OK Confirm Factory Init**.
 - Press **CLEAR MENU** to remove the menus from the screen.
 - b. *Modify the default settings:*
 - Press **SHIFT**; then press **ACQUIRE MENU**.
 - On the TDS 684A, press the main-menu button **Mode**; then press the side-menu button **Average 16**.
 - On the TDS 744, press the main-menu button **Mode**; then press the side-menu button **Hi Res**.
 - Press **CURSOR**.
 - Press the main-menu button **Function**; then press the side-menu button **H Bars**.
 - Press **CLEAR MENU**.
 - Be sure to disconnect any input signals from all four channels.
2. *Confirm input channels are within limits for offset accuracy at zero offset:* Do the following substeps — test CH 1 first, *skipping substep a since CH 1 is already set up to be checked from step 1*.
 - a. *Select an unchecked channel:* Press **WAVEFORM OFF** to remove the channel just confirmed from the display. Then, press the front-panel button that corresponds to the channel you are to confirm.

- b. *Set the vertical scale:* Set the vertical **SCALE** to one of the settings listed in Table 4–2 that is not yet checked. (Start with the first setting listed.)
- Press **VERTICAL MENU**. Press the main-menu button **Fine Scale**.
 - Use the keypad to enter the vertical scale. For the 1 mV setting, press **1**, **SHIFT**, **m**, then **ENTER**. For the 101 mV setting, press **101**, **SHIFT**, **m**, then **ENTER**. For the 1.01 V setting, press **1.01**, then **ENTER**.
 - Press **CLEAR MENU**.

Table 4–2: DC Offset Accuracy (Zero Setting)

Vertical Scale Setting	Vertical Position and Offset Setting ¹	TDS 684A Offset Accuracy Limits	TDS 744 Offset Accuracy Limits
1 mV	0	±1.45 mV	±1.6 mV
101 mV	0	±69.1 mV	±25.1 mV
1.01 V	0	±691 mV	±251 mV

¹ Vertical position is set to 0 divisions and vertical offset to 0 V when the oscilloscope is initialized in step 1.

- c. *Display the test signal:* The waveform position and offset were initialized for all channels in step 1 and are displayed as you select each channel and its vertical scale.
- d. *Measure the test signal:* Align the active cursor over the waveform by rotating the general purpose knob. Ignore the other cursor. See Figure 4–4.
- e. Read the measurement results at the absolute (@:) cursor readout, not the delta (Δ:) readout on screen. That is, read the offset relative to the ground reference. See Figure 4–4.
- f. *Check against limits:* Do the following subparts in the order listed.
- CHECK that the measurement results are within the limits listed for the current vertical scale setting.
 - Enter voltage on test record.
 - Repeat substeps b through f until all vertical scale settings listed in Table 4–2, are checked for the channel under test.

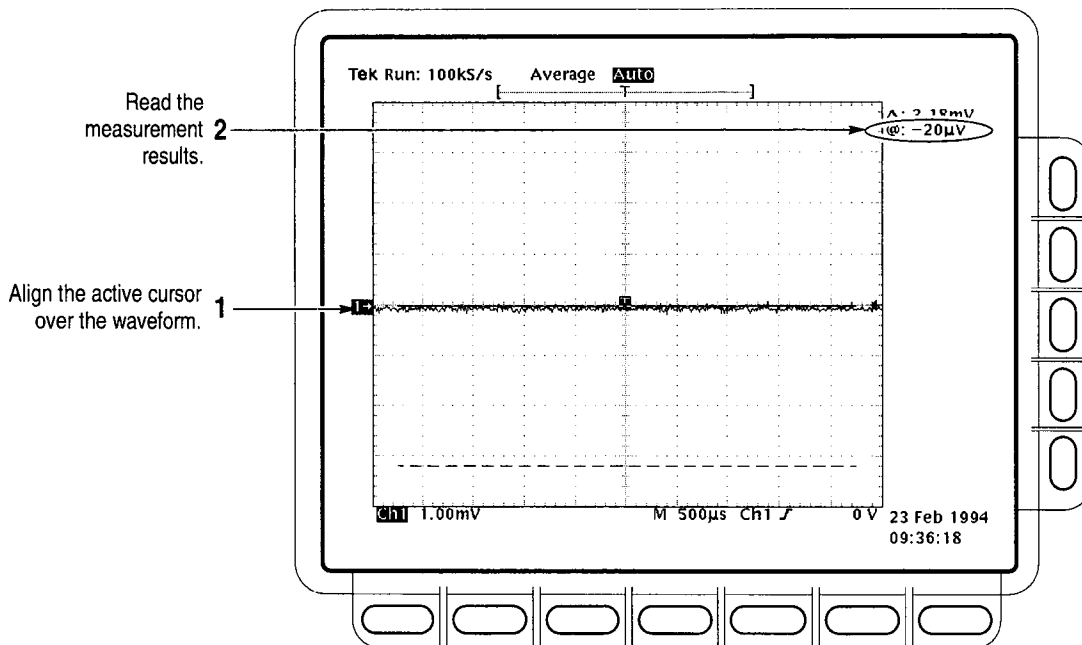

Figure 4-4: Measurement of DC Offset Accuracy at Zero Setting

- g. *Test all channels:* Repeat substeps a through f for all input channels.
- 3. *Disconnect the hookup:* No hookup was required.

Check DC Voltage Measurement Accuracy



WARNING. The generator is capable of outputting dangerous voltages. Be sure to set the DC calibration generator to 0 volts before connecting, disconnecting, and/or moving the test hookup during the performance of this procedure.

Equipment Required	Two dual-banana connectors (Item 6) One BNC T connector (Item 7) One DC calibration generator (Item 9) Two precision coaxial cables (Item 5)
Prerequisites	The oscilloscope must meet the prerequisites listed on page 4-15

1. *Install the test hookup and preset the instrument controls:*

a. *Hook up the test-signal source:*

- Set the output of a DC calibration generator to 0 volts.
- Connect the output of a DC calibration generator through a dual-banana connector followed by a 50 Ω precision coaxial cable to one side of a BNC T connector. See Figure 4-5.
- Connect the Sense output of the generator through a second dual-banana connector followed by a 50 Ω precision coaxial cable to the other side of the BNC T connector. Now connect the BNC T connector to CH 1. See Figure 4-5.

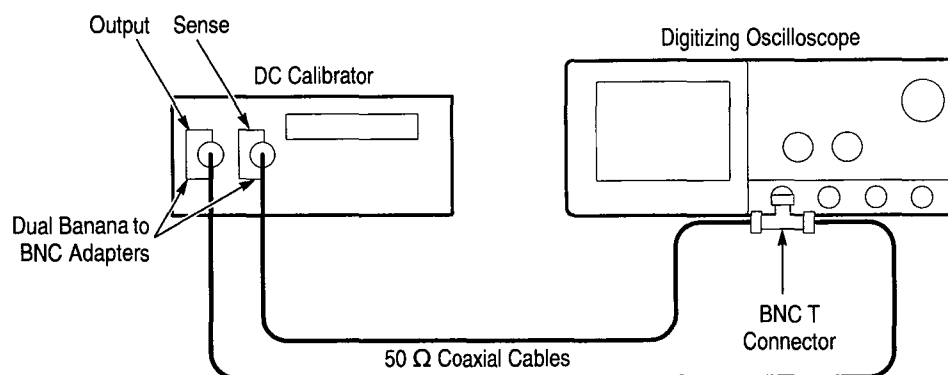

Figure 4-5: Initial Test Hookup

b. *Initialize the oscilloscope:*

- Press save/recall **SETUP**.
- Press the main-menu button **Recall Factory Setup**.
- Press the side-menu button **OK Confirm Factory Init**.

c. *Modify the default settings:*

- Press **SHIFT**; then press **ACQUIRE MENU**.
- Press the main-menu button **Mode**; then press the side-menu button **Average 16**.

2. *Confirm input channels are within limits for DC accuracy at maximum offset and position: Do the following substeps — test CH 1 first, skipping substep 2a since CH 1 is already selected from step 1.*

- a. *Select an unchecked channel:*
- Press **WAVEFORM OFF** to remove the channel just confirmed from the display.
 - Press the front-panel button that corresponds to the channel you are to confirm.
 - *Set the generator output to 0 V.*
 - Move the test hookup to the channel you selected.
- b. *Turn on the measurement Mean for the channel:*
- Press **MEASURE**, then press the main-menu button **Select Measrmt for CHx**.
 - Press the side-menu button **more** until the menu label **Mean** appears in the side menu (its icon is shown at the left). Press the side-menu button **Mean**.
 - Press **CLEAR MENU**.
- c. *Set the vertical scale:* Set the vertical **SCALE** to one of the settings listed in Table 4–3 that is not yet checked. (Start with the first setting listed.)



Table 4–3: DC Accuracy

Scale Setting	Position Setting (Divs)	Offset Setting	Generator Setting	TDS 684A Accuracy Limits	TDS 744 Accuracy Limits
5 mV	–5	+1 V	+1.040 V	+1.029 V to +1.0513 V	+1.0355 V to +1.0445 V
	+5	–1 V	–1.040 V	–1.0513 V to –1.029 V	–1.0445 V to –1.0355 V
200 mV	–5	+10 V	+11.6 V	+11.420 V to +11.786 V	+11.5385 V to +11.6615 V
	+5	–10 V	–11.6 V	–11.786 V to –11.420 V	–11.6615 V to –11.5385 V
1 V	–5	+10 V	+18V	+17.26 V to +18.76 V	+17.7785 V to +18.2215 V
	+5	–10 V	–18 V	–18.76 V to –17.26 V	–18.2215 V to –17.7785 V

- d. *Display the test signal:*
- Press **VERTICAL MENU**. Press the main-menu button **Position**.
 - Use the keypad to set vertical position to –5 divisions (press **–5**, then **ENTER**, on the keypad). The baseline level will move off screen.
 - Press the main-menu button **Offset**.

- Use the keypad to set vertical offset to the positive-polarity setting listed in the table for the current vertical scale setting. The baseline level will remain off screen.
 - Set the generator to the level and polarity indicated in the table for the vertical scale, position, and offset settings you have made. The DC test level should appear on screen. (If it doesn't return, the DC accuracy check is failed for the current vertical scale setting of the current channel.)
- e. *Measure the test signal:* Press **CLEAR MENU**. Read the measurement results at the **Mean** measurement readout. See Figure 4-6.

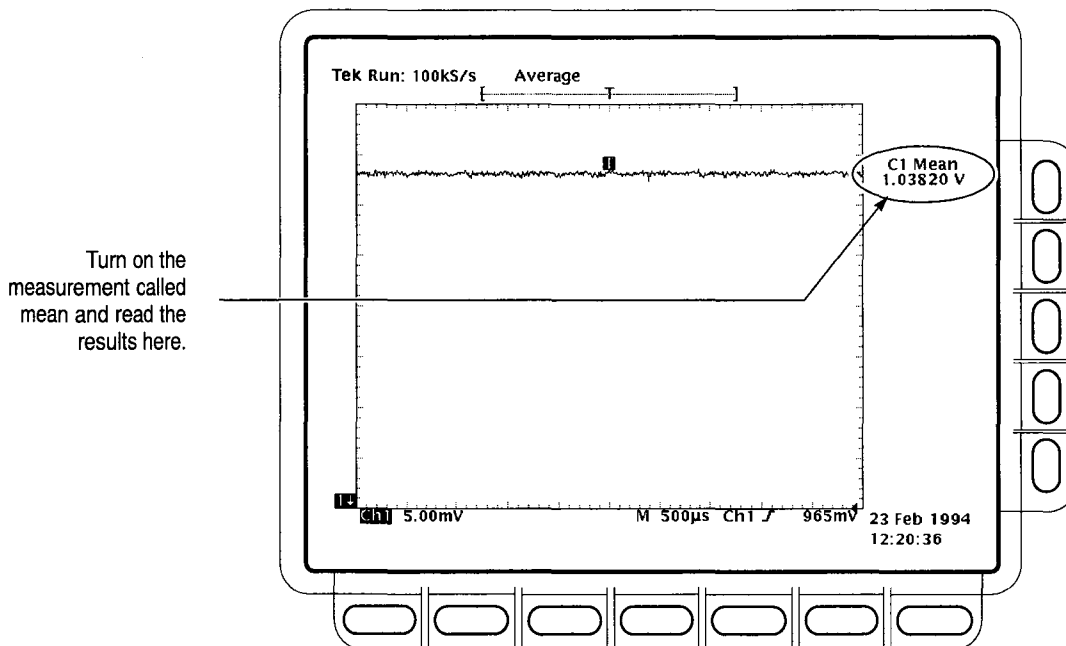

Figure 4-6: Measurement of DC Accuracy at Maximum Offset and Position

- f. *Check against limits:*
- CHECK that the readout for the measurement **Mean** readout on screen is within the limits listed for the current vertical scale and position/offset/generator settings. Enter value on test record.
 - Repeat substep d, reversing the polarity of the position, offset, and generator settings as is listed in the table.
 - CHECK that the **Mean** measurement readout on screen is within the limits listed for the current vertical scale setting and position/offset/generator settings. Enter value on test record.

- Repeat substeps c through f until all vertical scale settings, listed in Table 4-3, are checked for the channel under test.
 - g. *Test all channels:* Repeat substeps a through f for all four channels.
- 3. *Disconnect the hookup:*
 - a. *Set the generator output to 0 V.*
 - b. Disconnect the cable from the generator output at the input connector of the channel last tested.

Check Analog Bandwidth

Equipment Required	One high-frequency leveled sine wave generator and its leveling head (Item 12) Two 10X attenuators (Item 1)
Prerequisites	See page 4-15

1. *Install the test hookup and preset the instrument controls:*
 - a. *Initialize the oscilloscope:*
 - Press save/recall **SETUP**. Press the main-menu button **Recall Factory Setup**; then press the side-menu button **OK Confirm Factory Init**.
 - b. *Modify the default settings:*
 - Press **TRIGGER MENU**. Press the main-menu button **Coupling**.
 - Press the side-menu button **Noise Rej**.
 - Turn the horizontal **SCALE** knob to 50 ns. Press **SHIFT**; then press **ACQUIRE MENU**.
 - Press the main-menu button **Mode**; then press the side-menu button **Average 16**.
 - Press **MEASURE**. Press the main-menu button **High-Low Setup**; then press the side-menu button **Min-Max**.
 - c. *Hook up the test-signal source:* Connect, through its leveling head, the sine wave output of a high-frequency leveled sine wave generator to **CH 1**. Set the output of the generator to a reference frequency of 6 MHz. See Figure 4-7.

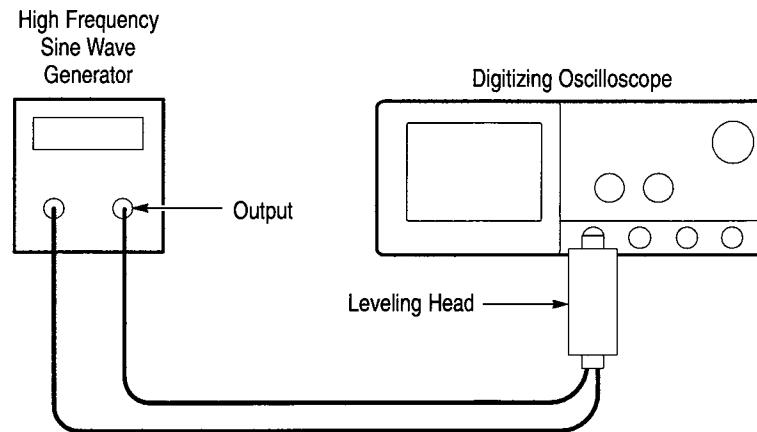

Figure 4-7: Initial Test Hookup

2. *Confirm the input channels are within limits for analog bandwidth:* Do the following substeps — test CH 1 first, *skipping substeps a and b since CH 1 is already set up for testing from step 1.*
 - a. *Select an unchecked channel:*
 - Press **WAVEFORM OFF** to remove the channel just confirmed from display.
 - Press the front-panel button that corresponds to the channel you are to confirm.
 - Move the leveling head to the channel you selected.
 - b. *Match the trigger source to the channel selected:*
 - Press **TRIGGER MENU**. Press the main-menu button **Source**; then press the side-menu button that corresponds to the channel selected.
 - c. *Set its input impedance:*
 - Press **VERTICAL MENU**; then press the main-menu button **Coupling**.
 - Press the side-menu Ω button to toggle it to the **50 Ω** setting.
 - d. *Set the vertical scale:* Set the vertical **SCALE** to one of the settings listed in Table 4-4 not yet checked. (Start with the 100 mV setting.)

Table 4-4: Analog Bandwidth

Vertical Scale	Attenuators (10X)	Reference Amplitude (at 6 MHz)	Horizontal Scale	TDS 684A Test Frequency	TDS 744 Test Frequency	Limits
100 mV	none	600 mV (6 divisions)	1 ns	1 GHz	500 MHz	≥424 mV
1 V	none	5 V (5 divisions)	1 ns	1 GHz	500 MHz	≥3.535 V
500 mV	none	3 V (6 divisions)	1 ns	1 GHz	500 MHz	≥2.121 V
200 mV	none	1.2 V (6 divisions)	1 ns	1 GHz	500 MHz	≥848 mV
50 mV	1	300 mV (6 divisions)	1 ns	1 GHz	500 MHz	≥212 mV
20 mV	1	120 mV (6 divisions)	1 ns	1 GHz	500 MHz	≥84.8 mV
10 mV	1	60 mV (6 divisions)	1 ns	1 GHz	500 MHz	≥42.4 mV
5 mV	2	30 mV (6 divisions)	1 ns	750 MHz	500 MHz	≥21.2 mV
2 mV	2	12 mV (6 divisions)	1 ns	600 MHz	350 MHz	≥8.48 mV
1 mV	2	6 mV (6 divisions)	1 ns	500 MHz	300 MHz	≥4.24 mV

e. *Display the test signal:* Do the following subparts to first display the reference signal and then the test signal.

- Press **MEASURE**; then press the main-menu button **Select Measrmt for CHx**.
- Press the side-menu button **more** until the menu label **Pk-Pk** appears in the side menu (its icon is shown at the left). Press the side-menu button **Pk-Pk**.
- Repeatedly press the side-menu button **more** until **Frequency** appears in the side menu (its icon is shown at the left). Press the side-menu button **Frequency**.
- Press **CLEAR MENU**.
- Set the generator output so the CHx Pk-Pk readout equals the reference amplitude in Table 4-4 that corresponds to the vertical scale set in substep d.
- Press the front-panel button **SET LEVEL TO 50%** as necessary to trigger a stable display. At full bandwidth (for TDS 684A = 1 GHz, for 744 = 500 MHz frequency), you may also want to make small, manual adjustments to the trigger level. You can use the **TRIGGER LEVEL** knob to do this.



f. *Measure the test signal:*

- Set the frequency of the generator, as shown on screen, to the test frequency in Table 4-4 that corresponds to the vertical scale set in substep d. See Figure 4-8.
- Set the horizontal **SCALE** to the horizontal scale setting in Table 4-4 that corresponds to the vertical scale set in substep d. Press **SET LEVEL TO 50%** as necessary to trigger the signal.
- Read the results at the CHx Pk-Pk readout, which will automatically measure the amplitude of the test signal. See Figure 4-8.

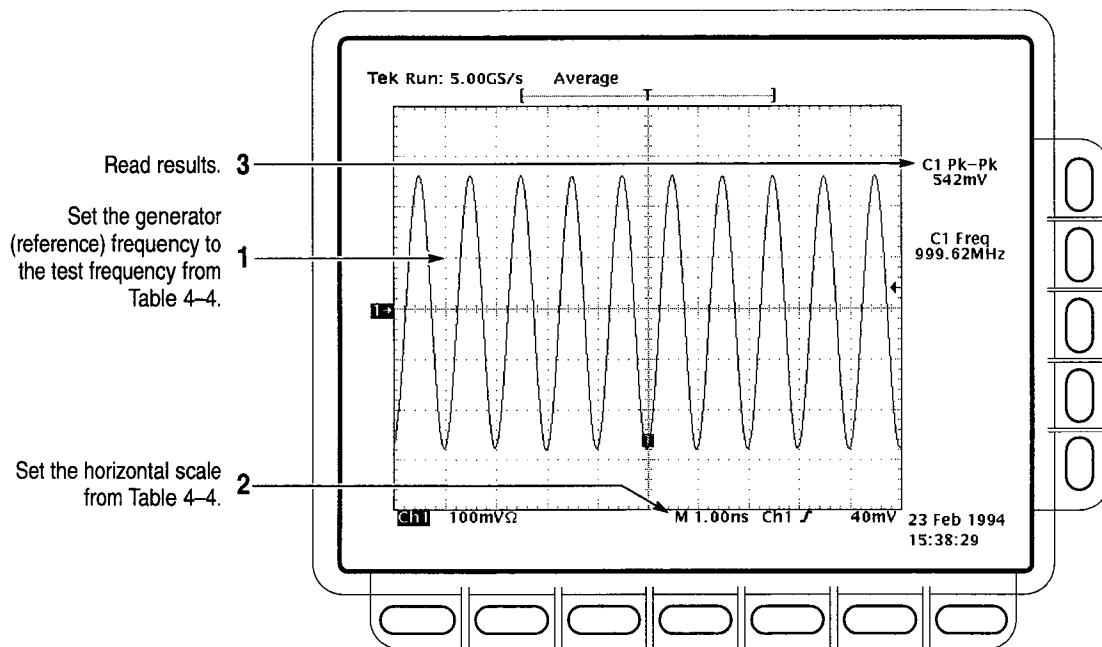

Figure 4-8: Measurement of Analog Bandwidth

g. *Check against limits:*

- CHECK that the **Pk-Pk** readout on screen is within the limits listed in Table 4-4 for the current vertical scale setting.
- Enter voltage on test record.
- When finished checking, set the horizontal **SCALE** back to the 50 ns setting.

STOP. *Checking each channel's bandwidth at all vertical scale settings is time consuming and unnecessary. You may skip checking the remaining vertical scale settings in Table 4-4 (that is, skip the following substep, h) if this digitizing oscilloscope has performed as follows:*

- Passed the 100 mV vertical scale setting just checked in this procedure.
- Passed the *Verify Internal Adjustment, Self Compensation, and Diagnostics* procedure found under *Self Tests*, on page 4-5.

NOTE. *Passing the signal path compensation confirms the signal path for all vertical scale settings for all channels. Passing the internal diagnostics ensures that the factory-set adjustment constants that control the bandwidth for each vertical scale setting have not changed.*

h. *Check remaining vertical scale settings against limits (optional):*

- If desired, finish checking the remaining vertical scale settings for the channel under test by repeating substeps d through g for each of the remaining scale settings listed in Table 4-4 for the channel under test.
- When doing substep e, skip the subparts that turn on the CHx Pk-Pk measurement until you check a new channel.
- Install/remove 10X attenuators between the generator leveling head and the channel input as needed to obtain the six division reference signals listed in the table.

i. *Test all channels:* Repeat substeps a through g for all four channels.

3. *Disconnect the hookup:* Disconnect the test hook up from the input connector of the channel last tested.

Check Delay Between Channels

Equipment Required	One medium-frequency leveled sine wave generator (Item 11) One precision coaxial cable (Item 5) One 50 Ω terminator (Item 4) One dual-input coupler (Item 8)
Prerequisites	See page 4-15

STOP. DO NOT use the vertical position knob to reposition any channel while doing this check. To do so invalidates the test.

1. Install the test hookup and preset the instrument controls:

a. Initialize the front panel:

- Press save/recall **SETUP**.
- Press the main-menu button **Recall Factory Setup**.
- Press the side-menu button **OK Confirm Factory Init**.

b. Modify the initialized front-panel control settings:

- Do *not* adjust the vertical position of any channel during this procedure.
- Set the horizontal **SCALE** to 500 ps.
- Press **SHIFT**; then press **ACQUIRE MENU**.
- Press the main-menu button **Mode**, and then press the side-menu button **Average 16**.

c. Hook up the test-signal source:

- Connect, through a 50 Ω precision coaxial cable followed by a 50 Ω termination, the sine wave output of a medium-frequency sine wave generator to a dual-input coupler. See Figure 4-9.
- Connect the coupler to both **CH 1** and **CH 2**. See Figure 4-9.

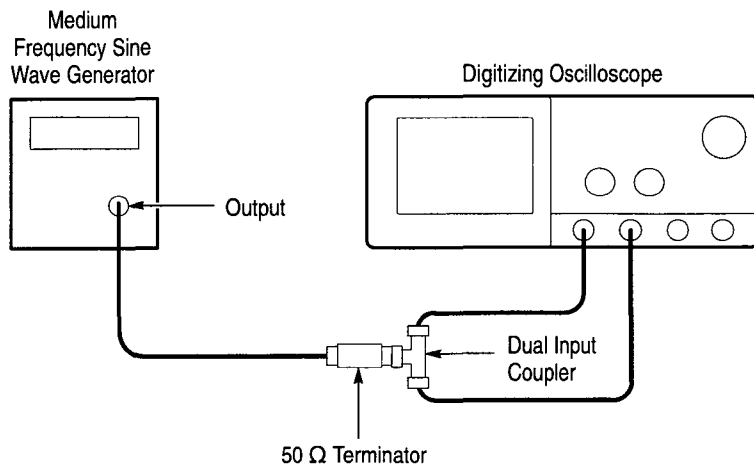

Figure 4-9: Initial Test Hookup

2. *Confirm all four channels (CH 1 through CH 4) are within limits for channel delay:*

- a. *Set up the generator:* Set the generator frequency to 250 MHz and the amplitude for about six divisions in CH 1.

Hint: As you are adjusting the generator amplitude, push **SET LEVEL TO 50%** frequently to speed up the updating of the waveform amplitude on screen.

- b. *Save a CH 2 waveform:* Press **CH 2**; then press save/recall **WAVEFORM**. Now, press the main-menu button **Save Wfm**; then press the side-menu button **To Ref 2**.

- c. *Save CH 3 waveform:*

- Move the coupler from **CH 2** to **CH 3**, so that **CH 1** and **CH 3** are driven. Press **WAVEFORM OFF**. Press **CH 3**; then press the side-menu button **To Ref 3**.

- d. *Display all test signals:*

- Press **WAVEFORM OFF** to remove CH 3 from the display.
- Display the live waveform. Move the coupler from **CH 3** to **CH 4**, so that CH 1 and CH 4 are driven. Press **CH 4** to display. See Figure 4-10 on page 4-40.
- Display the reference waveforms. To do this, press the front-panel button **MORE**. Press the main-menu buttons **Ref 2** and **Ref 3**. You may notice their overlapping ground reference indicators. See Figure 4-10 on page 4-40.

- e. *Measure the test signal:*

- Locate the time reference points for these waveforms. Do this by first identifying the point on the rising edge of the left-most waveform crosses the center horizontal graticule line. Next, note the corresponding *time reference point* for the right-most waveform. See Figure 4-10 on page 4-40.
- Press **CURSOR**.
- Press the main-menu button **Function**; then press the side-menu button **V Bars**.
- Press **CLEAR MENU**.
- Align one V bar cursor to the *time reference point* of the left-most waveform edge and the other cursor to the *time reference point* of the right-most waveform edge by rotating the General Purpose knob.

(Press **SELECT** to switch between the two cursors.) See Figure 4-10 on page 4-40.

- Read the measurement results at the Δ : cursor readout, not the @: readout on screen.

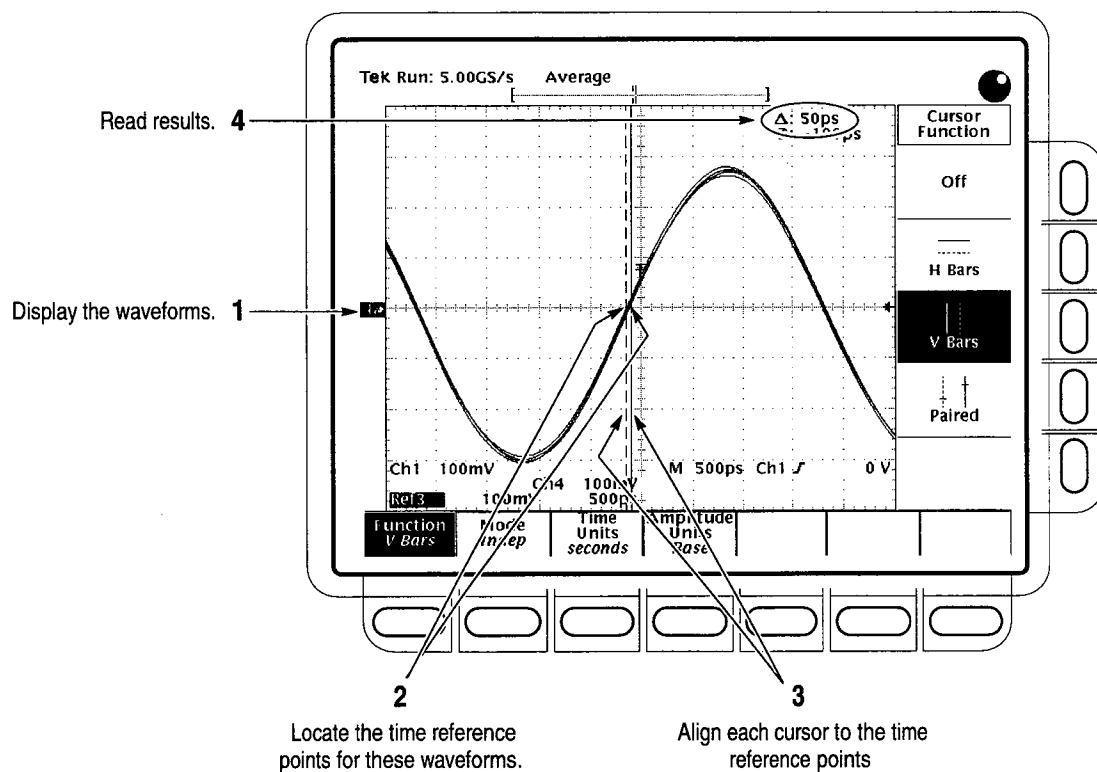

Figure 4-10: Measurement of Channel Delay

- f. *Check against limits:* CHECK that the cursor readout on screen is ≤ 100 ps.
 - g. Enter time on test record.
3. *Disconnect the hookup:* Disconnect the cable from the generator output at the input connectors of the channels.

Time Base System Checks

These procedures check those characteristics that relate to the Main and Delayed time base system and are listed as checked under *Warranted Characteristics in Specifications*.

Check Accuracy for Long-Term Sample Rate, Delay Time, and Delta Time Measurements

Equipment Required	One time-mark generator (Item 13) One 50 Ω , precision coaxial cable (Item 5)
Prerequisites	See page 4-15

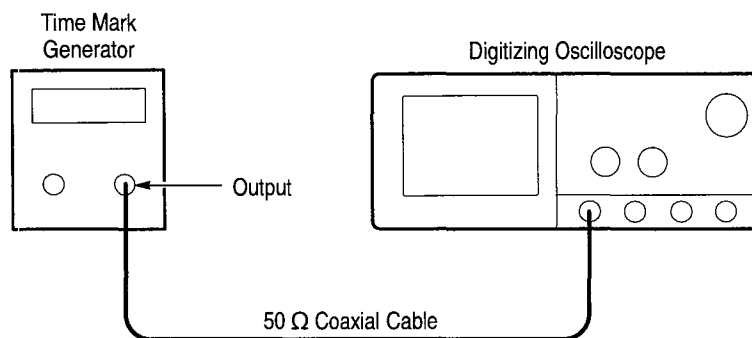

Figure 4-11: Initial Test Hookup

1. *Install the test hookup and preset the instrument controls:*
 - a. *Hook up the test-signal source:* Connect, through a 50 Ω precision coaxial cable, the time-mark output of a time-mark generator to **CH 1**. Set the output of the generator for 10 ms markers.
 - b. *Initialize the oscilloscope:*
 - Press save/recall **SETUP**. Press the main-menu button **Recall Factory Setup**. Press the side-menu button **OK Confirm Factory Init**.
 - c. *Modify the initialized front-panel control settings:*
 - Set the vertical **SCALE** to 500 mV.
 - Press **VERTICAL MENU**; then press the main-menu button **Coupling**. Press the side-menu button **Ω** to toggle it to the 50 Ω setting.
 - Press **SET LEVEL TO 50%**.
 - Use the vertical **POSITION** knob to center the test signal on screen.

- Set the horizontal **SCALE** of the Main time base to 1 ms.
 - Press **TRIGGER MENU**; then press the main-menu button **Mode & Holdoff**. Press the side-menu button **Normal**.
2. *Confirm Main and Delayed time bases are within limits for accuracies:*
- a. *Display the test signal:*
- Align the trigger **T** to the center vertical graticule line by adjusting the horizontal **POSITION**. See Figure 4–12 on page 4–43.
 - Press **HORIZONTAL MENU**.
 - Set horizontal modes. To do this, press the main-menu button **Time Base**. Press the side-menu buttons **Delayed Only** and **Delayed Runs After Main**. See Figure 4–12.
- b. *Measure the test signal:*
- Set the horizontal **SCALE** of the **D** (delayed) time base to 500 ns for the TDS 684A or to 100 ns for the TDS 744.
 - Set delayed time to 10 ms for the TDS 684A or the TDS 744 with serial # B020000 and up. Set delayed time to 10.0015 ms for the TDS 744 with serial number B019999 and below. Do this on the keypad by pressing **10** for the TDS 684A or later TDS 744 or by pressing **10.0015** for the earlier TDS 744, then **SHIFT**, then **m** followed by **ENTER**.)
- c. *Check long-term sample rate and delay time accuracies against limits:*
- **CHECK** that the rising edge of the marker crosses the center horizontal graticule line at a point within either ± 2.0 , for the TDS 684A, or ± 2.5 , for the TDS 744, divisions of center graticule. See Figure 4–12.
 - Enter number of divisions on test record.

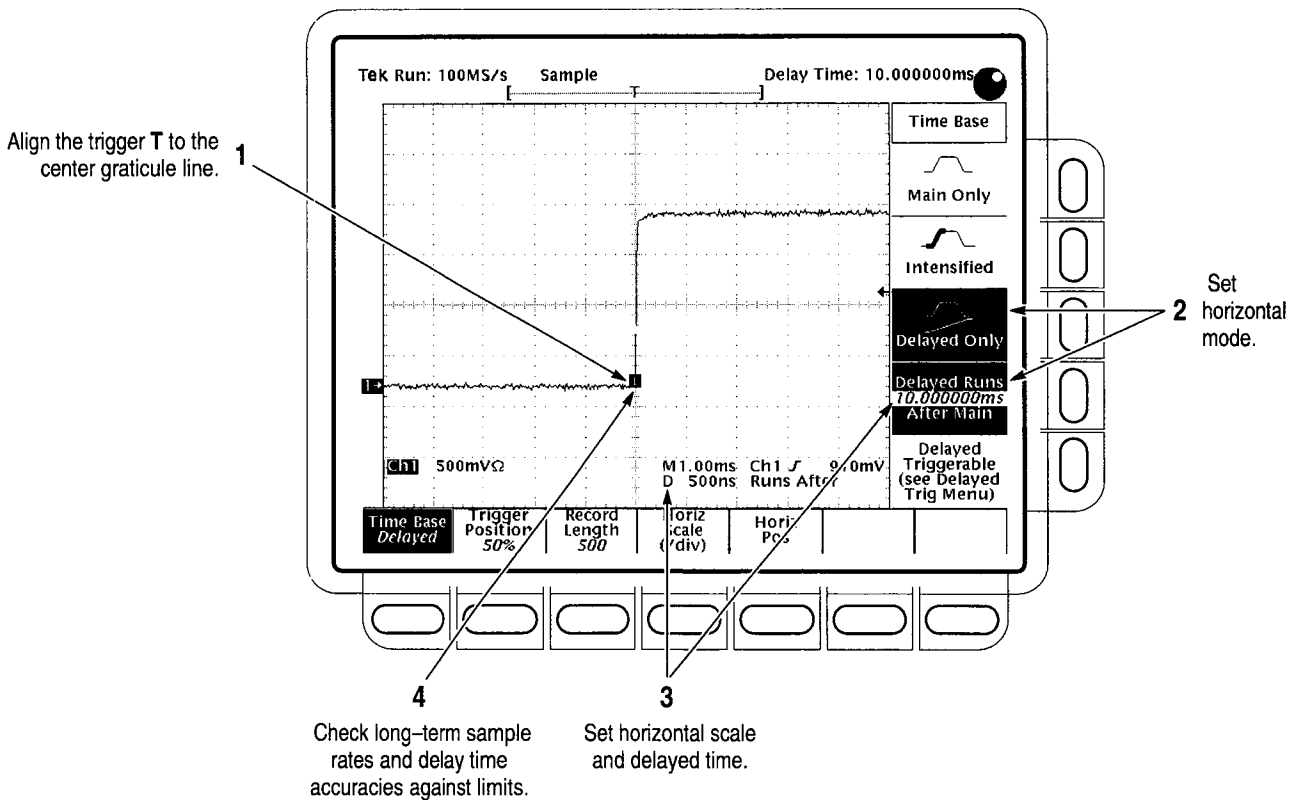

Figure 4-12: Measurement of Accuracy — Long-Term and Delay Time

3. *Disconnect the hookup:* Disconnect the cable from the generator output at the input connector of **CH 1**.

Trigger System Checks

These procedures check those characteristics that relate to the Main and Delayed trigger systems and are listed as checked in *Specifications*.

Check Accuracy (Time) for Pulse-Glitch or Pulse-Width Triggering

Equipment Required	One medium-frequency leveled sine wave generator (Item 11) One 10X attenuator (Item 1) One 50 Ω, precision coaxial cable (Item 5)
Prerequisites	See page 4-15

1. *Install the test hookup and preset the instrument controls:*
 - a. *Initialize the instrument:*
 - Press save/recall **SETUP**.
 - Press the main-menu button **Recall Factory Setup**.
 - Press the side-menu button **OK Confirm Factory Init**.
 - b. *Modify the default setup:*
 - Press **VERTICAL MENU**.
 - Press the main-menu button **Coupling**; then press the side-menu **Ω** button to select **50 Ω** coupling.
 - Set the horizontal **SCALE** to 10 ns on the TDS 684A and 12.5 ns on the TDS 744.

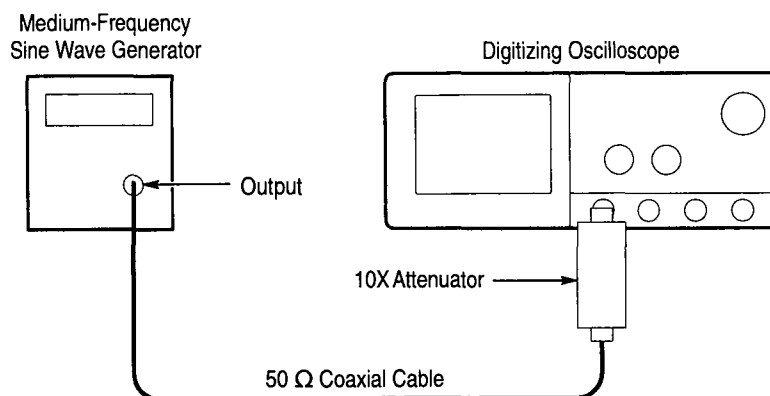

Figure 4-13: Initial Test Hookup

- c. *Hook up the test-signal source:* Connect the output of a medium-frequency leveled sine wave generator (Item 11) to CH 1. Do this through a 50 Ω precision coaxial cable, followed by a 10X attenuator. See Figure 4-13 on page 4-44.
2. *Confirm the trigger system is within time-accuracy limits for pulse-glitch or pulse-width triggering (Horizontal Scale $\leq 1 \mu\text{s}$):*
 - a. *Display the test signal:* Set the output of the sine wave generator for a 100 MHz, five-division sine wave on screen. Press **SET LEVEL TO 50%**.

- b. *Set the trigger mode:* Press **TRIGGER MENU**. Now press the main-menu button **Mode & Holdoff**; then press the side-menu button **Normal**.
- c. *Set upper and lower limits that ensure triggering:* See Figure 4–14.
- Press the main-menu button **Type**; then repeatedly press the same button until **Pulse** is highlighted in the menu that pops up.
 - Press the main-menu button **Class**; then repeatedly press the same button until **Width** is highlighted in the menu that pops up.
 - Press the main-menu button **Trig When**; then press the side-menu button **Within Limits**.
 - Press the side-menu button **Upper Limit**. Use the keyboard to set the upper limit to 10 ns: press **10**, then **SHIFT**, then **n**, and **ENTER**.
 - Press the side-menu button **Lower Limit**. Use the keypad to set the lower limit to 2 ns.
- d. *Change limits until triggering stops:*
- Press **SET LEVEL TO 50%**.
 - While doing the following subparts, monitor the display (it will stop acquiring) and the front-panel light **TRIG** (it will extinguish) to determine when triggering is lost.
 - Use the general purpose knob to *increase* the **Lower Limit** readout until triggering is lost.
 - CHECK that the **Lower Limit** readout, after the oscilloscope loses triggering, is within 2.5 ns to 7.5 ns, inclusive, for the TDS 684A or is within 3.5 ns to 6.5 ns, inclusive, for the TDS 744.
 - Enter time on test record.
 - Use the keypad to return the **Lower Limit** to 2 ns and reestablish triggering.
 - Press the side-menu button **Upper Limit**; then use the general purpose knob to slowly *decrease* the **Upper Limit** readout until triggering is lost.
 - CHECK that the **Upper Limit** readout, after the oscilloscope loses triggering, is within 2.5 ns to 7.5 ns, inclusive, for the TDS 684A or is within 2.5 ns to 6.5 ns, inclusive, for the TDS 744.
 - Enter time on test record.

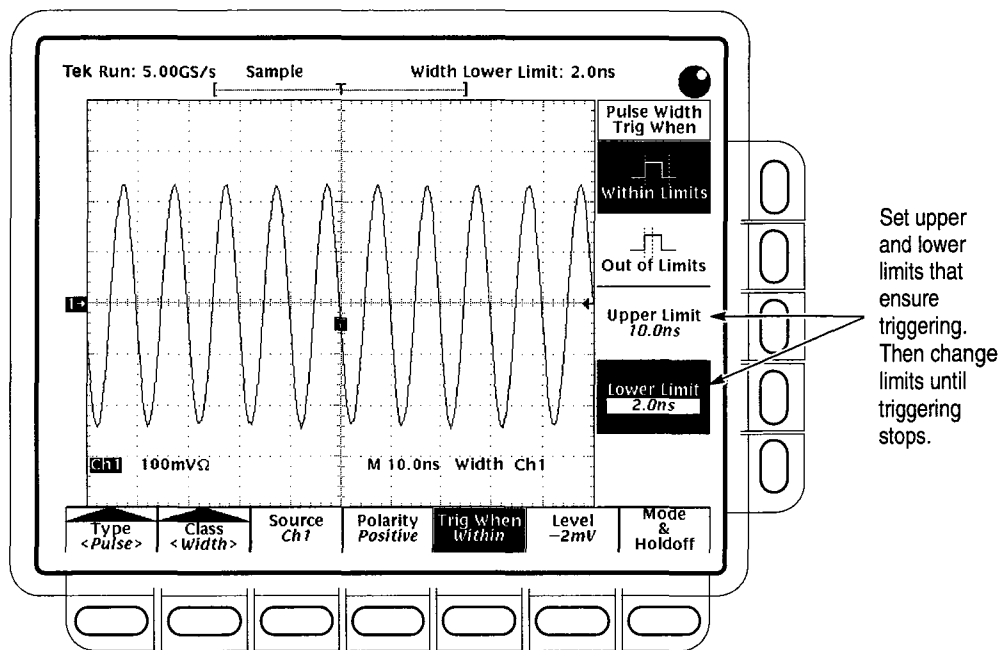

Figure 4-14: Measurement of Time Accuracy for Pulse and Glitch Triggering

3. Confirm the trigger system is within time-accuracy limits for pulse-glitch or pulse-width triggering (horizontal scale $>1 \mu\text{s}$):

a. Set upper and lower limits that ensure triggering at 250 kHz:

- Press the side-menu button **Upper Limit**. Use the keyboard to set the upper limit to $4 \mu\text{s}$.
- Press the side-menu button **Lower Limit**. Use the keypad to set the lower limit to 500 ns.

b. Display the test signal:

- Set the horizontal **SCALE** to $5 \mu\text{s}$.
- Set the output of the sine wave generator for a 250 kHz, five-division sine wave on screen. Set the vertical **SCALE** to 20 mV (the waveform will overdrive the display).
- Press **SET LEVEL TO 50%**.

c. Check against limits: Do the following subparts in the order listed.

- Use the general purpose knob to *increase* **Lower Limit** readout until triggering is lost.

- CHECK that the **Lower Limit** readout, after the oscilloscope stops triggering, is within $1\ \mu\text{s}$ to $3\ \mu\text{s}$, inclusive, for the TDS 684A or is within $1.9\ \mu\text{s}$ to $2.1\ \mu\text{s}$, inclusive, for the TDS 744.
 - Enter time on test record.
 - Use the keypad to return the **Lower Limit** to 500 ns and reestablish triggering.
 - Press the side-menu button **Upper Limit**; then use the general purpose knob to slowly *decrease* the **Upper Limit** readout until triggering stops.
 - CHECK that the **Upper Limit** readout, after the oscilloscope loses triggering, is within $1\ \mu\text{s}$ to $3\ \mu\text{s}$, inclusive, for the TDS 684A or is within $1.9\ \mu\text{s}$ to $2.1\ \mu\text{s}$, inclusive, for the TDS 744.
 - Enter time on test record.
4. *Disconnect the hookup:* Disconnect the cable from the generator output at the input connector of **CH 1**.

**Check Accuracy,
Trigger-Level or
Threshold, DC Coupled**

Equipment Required	One DC calibration generator (Item 9) One BNC T connector (Item 7) Two 50 Ω , precision coaxial cables (Item 5)
Prerequisites	See page 4–15.

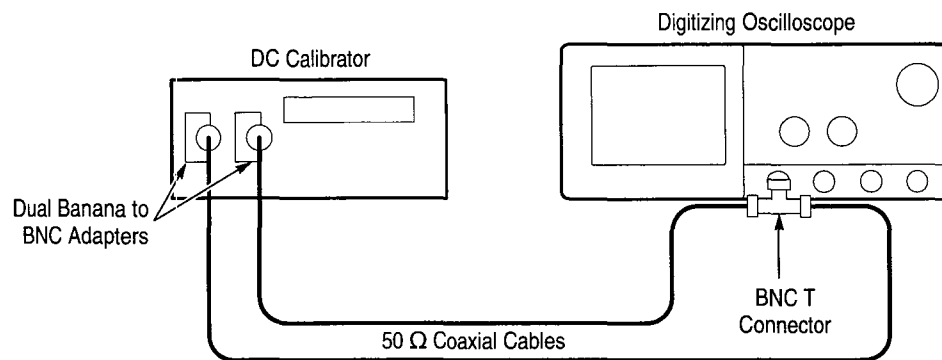

Figure 4–15: Initial Test Hookup

1. *Install the test hookup and preset the instrument controls:*
 - a. *Hook up the test-signal source:*
 - Set the output of the DC calibration generator to 0 volts.

- Connect the output of the DC calibration generator, through a dual-banana connector followed by a 50 Ω precision coaxial cable, to one side of a BNC T connector.
 - Connect the Sense output of the generator, through a second dual-banana connector followed by a 50 Ω precision coaxial cable, to other side of the BNC T connector. Now connect the BNC T connector to **CH 1**.
- b. *Initialize the oscilloscope:*
- Press save/recall **Setup**.
 - Press the main-menu button **Recall Factory Setup**.
 - Press the side-menu button **OK Confirm Factory Init**.
2. *Confirm Main trigger system is within limits for Trigger-level/Threshold accuracy:*
- a. *Display the test signal:*
- Set the vertical **SCALE** to 200 mV.
 - Press **VERTICAL MENU**, then press the main-menu button **Position**.
 - Set vertical position to -3 divisions (press **-3**, then **ENTER**, on the keypad.) The baseline level will move down three divisions. See Figure 4-16 on page 4-49.
 - Press the main-menu button **Offset**.
 - Set vertical offset to +10 volts with the keypad. The baseline level will move off screen.
 - Set the standard output of the DC calibration generator equal to the offset (+10 volts). The DC test level will appear on screen. See Figure 4-16.
- b. *Measure the test signal:*
- Press **SET LEVEL TO 50%**.
 - Press **TRIGGER MENU**.
 - Read the measurement results from the readout below the label **Level** in the main menu, not the trigger readout in the graticule area.

c. *Read results (Check against limits):* See Figure 4–16.

- CHECK that the **Level** readout in the main menu is within 9.863 V to 10.137 V, inclusive, for the TDS 684A or is within 9.9393 V to 10.1147 V, inclusive, for the TDS 744.
- Enter voltage on test record.
- Press the main-menu button **Slope**; then press the side-menu button for negative slope. See icon at left. Repeat substep b.
- CHECK that the **Level** readout in the main menu is within 9.863 V to 10.137 V, inclusive, for the TDS 684A or is within 9.9393 V to 10.1147 V, inclusive, for the TDS 744.
- Enter voltage on test record.

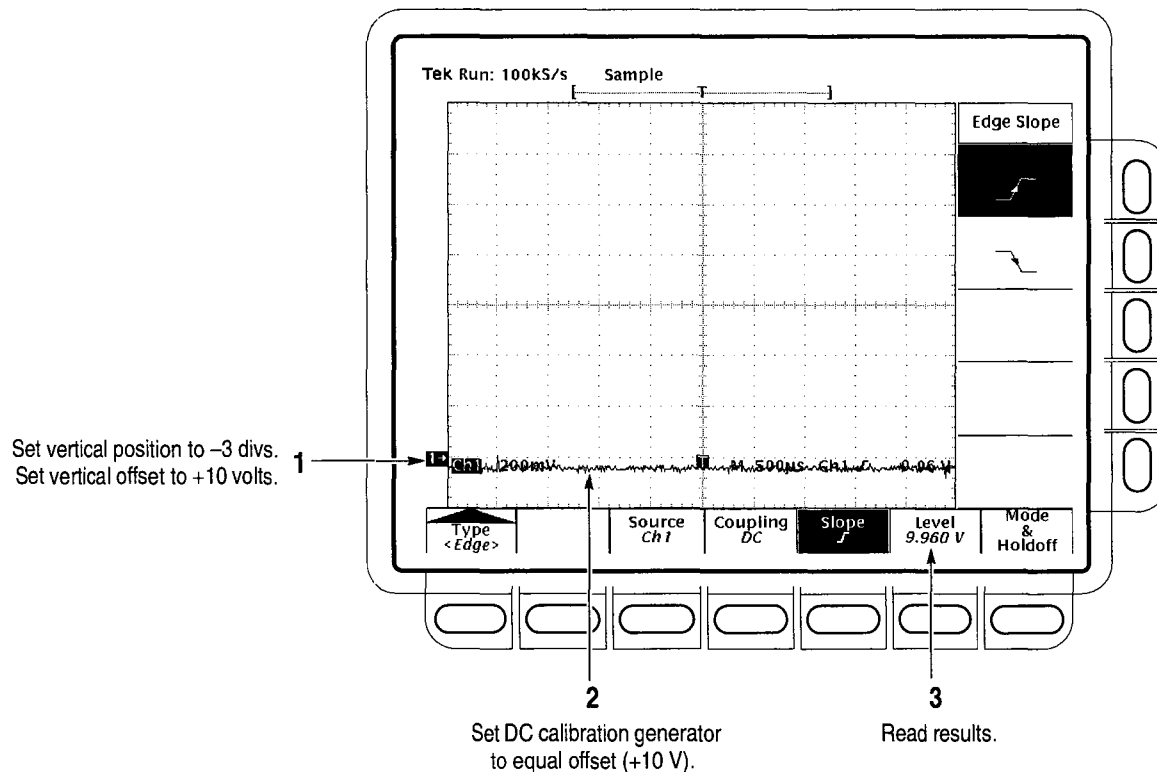

Figure 4–16: Measurement of Trigger-Level Accuracy

3. *Confirm Delayed trigger system is within limits for Trigger-level/Threshold accuracy:*
 - a. *Select the Delayed time base:*

- Press **HORIZONTAL MENU**.
 - Press the main-menu button **Time Base**.
 - Press the side-menu buttons **Delayed Only** and **Delayed Triggerable**.
 - Set **D** (delayed) horizontal **SCALE** to 500 μ s.
- b. *Select the Delayed trigger system:*
- Press **SHIFT**; then press the front-panel **DELAYED TRIG** button.
 - Press the main-menu button **Level**.
- c. *Measure the test signal:* Press the side-menu button **SET TO 50%**. Read the measurement results in the side (or main) menu below the label **Level**.
- d. *Check against limits:* Do the following subparts in the order listed.
- CHECK that the **Level** readout in the side menu is within 9.863 V to 10.137 V, inclusive, for the TDS 684A or is within 9.9393 V to 10.1147 V, inclusive, for the TDS 744.
 - Enter voltage on test record.
 - Press the main-menu button **Slope**; then press the side-menu button for negative slope. See icon at left. Press the main-menu button **Level**. Repeat substep c.
 - CHECK that the **Level** readout in the side menu is within 9.863 V to 10.137 V, inclusive, for the TDS 684A or is within 9.9393 V to 10.1147 V, inclusive, for the TDS 744.
 - Enter voltage on test record.
4. *Disconnect the hookup:*
- a. *First set the output of the DC calibration generator to 0 volts.*
 - b. Disconnect the cable from the generator output at the input connector of **CH 1**.



**Sensitivity, Edge Trigger,
DC Coupled**

Equipment Required	One medium-frequency leveled sine wave generator (Item 11) One high-frequency leveled sine wave generator (Item 12) Two precision 50 Ω coaxial cables (Item 5) One 10X attenuator (Item 1) One BNC T connector (Item 7) One 5X attenuator (Item 2)
Prerequisites	See page 4–15.

1. Install the test hookup and preset the instrument controls:**a. Initialize the oscilloscope:**

- Press save/recall **SETUP**.
- Press the main-menu button **Recall Factory Setup**.
- Press the side-menu button **OK Confirm Factory Init**.

b. Modify the initialized front-panel control settings:

- Set the horizontal **SCALE** for the **M** (main) time base to 20 ns on the TDS 684A or 25 ns on the TDS 744.
- Press **HORIZONTAL MENU**; then press the main-menu button **Time Base**.
- Press the side-menu button **Delayed Only**; then press the side-menu button **Delayed Triggerable**.
- Set the horizontal **SCALE** for the **D** (delayed) time base to 20 ns on the TDS 684A or 25 ns on the TDS 744; then press the side-menu button **Main Only**.
- Press **TRIGGER MENU**; then press the main-menu button **Mode & Holdoff**. Press the side-menu button **Normal**.
- Press **VERTICAL MENU**; then press the main-menu button **Coupling**. Press the side-menu button Ω to select the 50 Ω setting.
- Press **SHIFT**; then press **ACQUIRE MENU**. Press the main-menu button **Mode**; then press the side-menu button **Average 16**.

c. Hook up the test-signal source:

- Connect the signal output of a medium-frequency sine wave generator to a BNC T connector. Connect one output of the T connector to **CH 1** through a 50 Ω precision coaxial cable. Connect

the other output of the T connector to the **AUX TRIG INPUT** at the rear panel. See Figure 4-17.

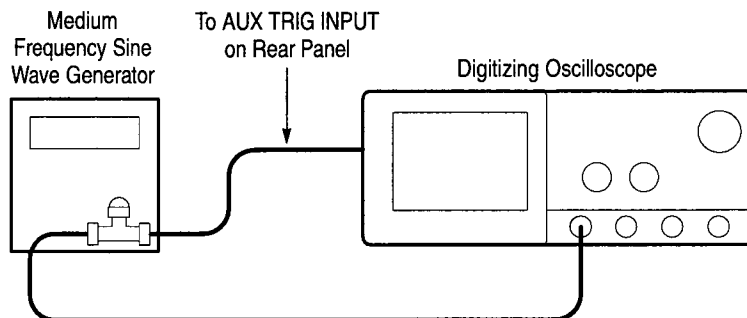

Figure 4-17: Initial Test Hookup

2. *Confirm Main and Delayed trigger systems are within sensitivity limits (50 MHz):*

a. *Display the test signal:*

- Set the generator frequency to 50 MHz.
- Press **MEASURE**.
- Press the main-menu button **High-Low Setup**; then press the side-menu button **Min-Max**.
- Press the main-menu button **Select Measrmt for Ch1**.
- Press the side-menu button **—more—** until **Amplitude** appears in the side menu (its icon is shown at the left). Press the side-menu button **Amplitude**.
- Press **SET LEVEL TO 50%**.
- Press **CLEAR MENU**.
- Set the test signal amplitude for about three and a half divisions on screen. Now fine adjust the generator output until the **CH 1 Amplitude** readout indicates the amplitude is 350 mV. Readout may fluctuate around 350 mV.
- Disconnect the 50 Ω precision coaxial cable at **CH 1** and reconnect it to **CH 1** through a 10X attenuator.



b. *Check the Main trigger system for stable triggering at limits:*

- Read the following definition: A stable trigger is one that is consistent; that is, one that results in a uniform, regular display

- c. *Check Delayed trigger system for stable triggering at limits:* Do the following subparts in the order listed.
- Press **HORIZONTAL MENU**; then press the main-menu button **Time Base**. Press the side-menu button **Delayed Only**; then press **Delayed Triggerable** in the same menu.
 - Press **SHIFT**; then press **DELAYED TRIG**. Press the main-menu button **Level**.
 - Press the side-menu button **SET TO 50%**.

CHECK that a stable trigger is obtained for the test waveform for both the positive and negative slopes of the waveform. Use the **TRIGGER LEVEL** knob to stabilize the Main trigger. Use the general purpose knob to stabilize the Delayed trigger. Press the main-menu button **Slope**; then use the side menu to switch between trigger slopes. See Figure 4–18.

- Enter pass/fail result for delayed trigger on the test record.
 - Leave the Delayed trigger system triggered on the positive slope of the waveform before continuing to the next step. Also, return to the main time base: Press **HORIZONTAL MENU**; then press the main-menu button **Time Base**. Press the side-menu button **Main Only**.
 - Press **CLEAR MENU**.
3. *Confirm the AUX Trigger input:*

a. *Display the test signal:*

- Remove the 10X attenuator and reconnect the cable to **CH 1**.
- Set the test signal amplitude for about 2.5 divisions on screen.
- Now fine adjust the generator output until the **CH 1 Amplitude** readout indicates the amplitude is 250 mV. (Readout may fluctuate around 250 mV.)

b. *Check the AUX trigger source for stable triggering at limits:* Do the following in the order listed.

- Use the definition for stable trigger from step 2.
- Press **TRIGGER MENU**; then press the main-menu button **Source**.
- Press the side-menu button **–more–** until the side-menu label **DC Aux** appears; then press **DC Aux**.

- Press **SET LEVEL TO 50%**. CHECK that a stable trigger is obtained for the test waveform on both the positive and negative slopes. Press the main-menu button **Slope**; then use the side menu to switch between trigger slopes. Use the **TRIGGER LEVEL** knob to stabilize the trigger if required.
 - Enter the pass/fail result on the test record.
 - Leave the Main trigger system triggered on the positive slope of the waveform before proceeding to the next check.
 - Press the main-menu button **Source**; then press the side-menu button **–more–** until **CH 1** appears. Press **CH 1**.
4. *Confirm that the Main and Delayed trigger systems are within sensitivity limits (full bandwidth, for TDS 684A = 1 GHz, for TDS 744 = 500 MHz):*
- a. *Hook up the test-signal source:* Disconnect the hookup installed in step 1. Connect, through its leveling head, the signal output of a high-frequency leveled sine wave generator to **CH 1**.
 - b. *Set the Main and Delayed Horizontal Scales:*
 - Set the horizontal **SCALE** to 500 ps for the **M** (Main) time base.
 - Press **HORIZONTAL MENU**. Now press the main-menu button **Time base**; then press the side-menu button **Delayed Triggerable**.
 - Press the side-menu button **Delayed Only**.
 - Set the horizontal **SCALE** to 500 ps for the **D** (Delayed) time base. Press the side-menu button **Main Only**.
 - c. *Display the test signal:*
 - Set the generator frequency to full bandwidth (for TDS 684A = 1 GHz, for 744 = 500 MHz).
 - Set the test signal amplitude for about five divisions on screen. Now fine adjust the generator output until the **CH 1 Amplitude** readout indicates the amplitude is 500 mV. (Readout may fluctuate around 500 mV.)
 - Disconnect the leveling head at **CH 1** and reconnect it to **CH 1** through a 5X attenuator.
 - d. Repeat step 2, substeps b and c only, since only the full bandwidth (for TDS 684A = 1 GHz, for 744 = 500 MHz) is to be checked here.

NOTE. You just checked the trigger sensitivity. If desired, you may repeat steps 1 through 4 for the other channels (CH2, CH3, and CH4).

5. *Disconnect the hookup:* Disconnect the cable from the channel last tested.

Output Signal Checks

The procedure that follows checks those characteristics of the output signals that are listed as checked under *Warranted Characteristics* in *Specifications*. The oscilloscope outputs these signals at its front and rear panels.

Check Outputs — CH 3 Main and Delayed Trigger

Equipment Required	Two 50 Ω precision cables (Item 5) One calibration generator (Item 10)
Prerequisites	See page 4–15. Also, the Digitizing Oscilloscope must have passed <i>Check DC Voltage Measurement Accuracy</i> on page 4–29.

1. *Install the test hookup and preset the instrument controls:*

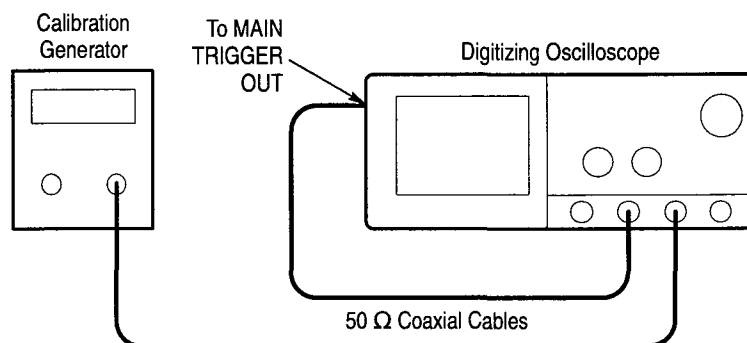

Figure 4–19: Initial Test Hookup

- a. *Hook up test-signal source 1:*
 - Connect the standard amplitude output of a calibration generator through a 50 Ω precision coaxial cable to **CH 3**.
 - Set the output of the calibration generator to 0.500 V.
- b. *Hook up test-signal source 2:* Connect the **Main Trigger Out** at the rear panel to **CH 2** through a 50 Ω precision cable.
- c. *Initialize the oscilloscope:*

- Press save/recall **SETUP**.
 - Press the main-menu button **Recall Factory Setup**.
 - Press the side-menu button **OK Confirm Factory Init**.
- d. *Modify the initialized front-panel control settings:*
- Set the horizontal **SCALE** to 200 μ s.
 - Press **SHIFT**; then press **ACQUIRE MENU**.
 - Press the main-menu button **Mode**; then press the side-menu button **Average**.
 - Select **64** averages.
2. *Confirm Main and Delayed Trigger outputs are within limits for logic levels:*
- a. *Display the test signal:*
- Press **WAVEFORM OFF** to turn off CH 1.
 - Press **CH 2** to display that channel.
 - Set the vertical **SCALE** to 1 V.
 - Use the vertical **POSITION** knob to center the display on screen.
- b. *Measure logic levels:*
- Press **MEASURE**; then press the main-menu button **Select Measurement for Ch2**.
 - Select high and low measurements. To do this, repeatedly press the side-menu button **more** until **High** and **Low** appear in the side menu (their icons are shown at the left). Press both side-menu buttons **High** and **Low**.
- c. *Check Main Trigger output against limits:*
- CHECK that the **Ch2 High** readout is ≥ 2.5 volts and that the **Ch2 Low** readout is ≤ 0.7 volts. See Figure 4–20.
 - Enter high and low voltages on test record.
 - Press **VERTICAL MENU**; then press the main-menu button **Coupling**. Now press the side-menu button Ω to toggle it to the 50 Ω setting.
 - CHECK that the **Ch2 High** readout is ≥ 1.0 volt and that the **Ch2 Low** readout ≤ 0.25 volts.
 - Enter high and low voltages on test record.



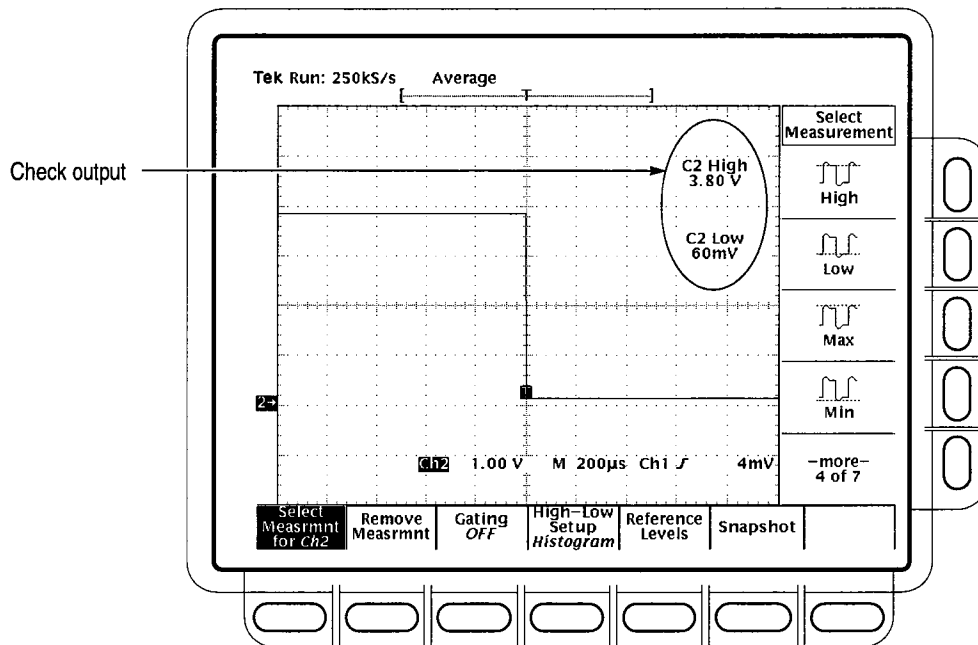

Figure 4-20: Measurement of Main Trigger Out Limits

d. *Check Delayed Trigger output against limits:* See Figure 4-20.

- Move the precision 50 Ω cable from the rear-panel **Main Trigger Output** BNC to the rear-panel **Delayed Trigger Output** BNC.
- CHECK that the **Ch2 High** readout is ≥ 1.0 volt and that the **Ch2 Low** readout ≤ 0.25 volts.
- Enter high and low voltages on test record.
- Press the side-menu button Ω to select the 1 M Ω setting.
- Press **CLEAR MENU**.
- CHECK that the **Ch2 High** readout is ≥ 2.5 volts and that the **Ch2 Low** readout is ≤ 0.7 volts.
- Enter high and low voltages on test record.

3. *Confirm CH 3 output is within limits for gain:*

a. *Measure gain:*

- Move the precision 50 Ω cable from the rear-panel **DELAYED TRIGGER OUTPUT** BNC to the rear-panel **SIGNAL OUT** BNC.
- Push **TRIGGER MENU**.



- Press the main-menu button **Source**.
 - Press the side-menu button **Ch3**.
 - Set vertical **SCALE** to 100 mV.
 - Press **SET LEVEL TO 50%**.
 - Press **MEASURE**; then press the main-menu button **Select Measrmt for Ch2**.
 - Repeatedly press the side-menu button **–more–** until **Pk-Pk** appears in the side menu (its icon is shown at the left). Press the side-menu button **Pk-Pk**.
 - Press **CLEAR MENU**.
- b. *Check against limits:*
- CHECK that the readout **Ch2 Pk-Pk** is between 80 mV and 120 mV, inclusive, for the TDS 684A or is between 88 mV and 132 mV, inclusive, for the TDS 744.
 - Enter voltage on test record.
 - Press **VERTICAL MENU**; then press the side-menu button **Ω** to toggle to the 50 Ω setting.
 - Press **CLEAR MENU**.
 - CHECK that the readout **Ch2 Pk-Pk** is between 40 mV and 60 mV, inclusive, for the TDS 684A or is between 44 mV and 66 mV, inclusive, for the TDS 744.
 - Enter voltage on test record.
4. *Disconnect the hookup:* Disconnect the cables from the channel inputs and the rear panel outputs.

Check Probe Compensator Output

Equipment Required	One female BNC to clip adapter (Item 3) Two dual-banana connectors (Item 6) One BNC T connector (Item 7) Two 50 Ω precision cables (Item 5) One DC calibration generator (Item 9)
Prerequisites	See page 4–15. Also, the Digitizing Oscilloscope must have passed <i>Check Accuracy For Long-Term Sample Rate, Delay Time, and Delta Time Measurement</i> on page 4–41.

1. *Install the test hookup and preset the instrument controls:*

a. *Hook up test-signal:*

- Connect one of the 50 Ω cables to **CH 1**. See Figure 4–21.
- Connect the other end of the cable just installed to the female BNC-to-clips adapter. See Figure 4–21.
- Connect the red clip on the adapter just installed to the **PROBE COMPENSATION SIGNAL** on the front panel; connect the black clip to **PROBE COMPENSATION GND**. See Figure 4–21.

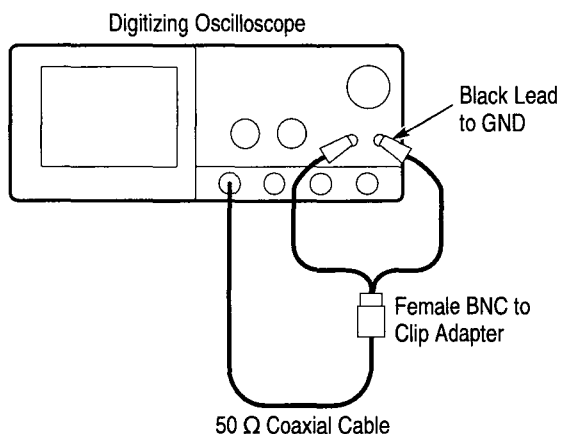

Figure 4–21: Initial Test Hookup

b. *Initialize the oscilloscope:*

- Press save/recall **SETUP**.
- Press the main-menu button **Recall Factory Setup**.
- Press the side-menu button **OK Confirm Factory Init**.

c. *Modify the initialized front-panel control settings:*

- Set the horizontal **SCALE** to 200 μ s.
- Press **SET LEVEL TO 50%**.
- Use the vertical **POSITION** knob to center the display on screen.
- Press **SHIFT**; then press **ACQUIRE MENU**.
- Press the main-menu button **Mode**; then press the side-menu button **Average**.

- Select **128** averages.
2. *Confirm that the Probe Compensator signal is within limits for frequency:*
- a. *Measure the frequency of the probe compensation signal:*
 - Press **MEASURE**; then press the main-menu button **Select Measrmt for Ch1**.
 - Repeatedly press the side-menu button **–more–** until **Frequency** appears in the side menu (its icon is shown at the left). Press the side-menu button **Frequency**.
 - b. *Check against limits:*
 - **CHECK** that the **CH 1 Freq** readout is within 950 Hz to 1.050 kHz, inclusive. See Figure 4–22.
 - Enter frequency on test record.
 - Press **MEASURE**; then press the main-menu button **Remove Measrmt for Ch1**. Press the side–menu **Measurement 1**.

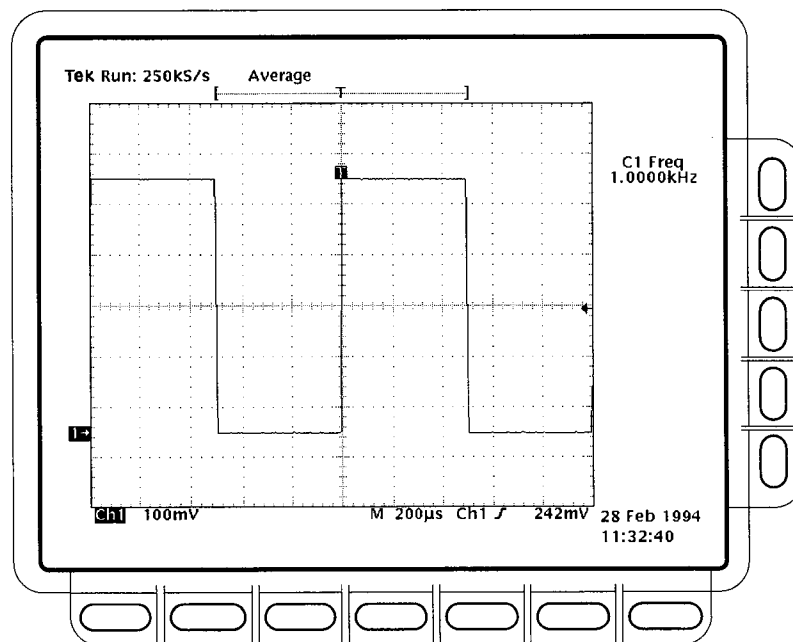

Figure 4–22: Measurement of Probe Compensator Frequency

- c. *Save the probe compensation signal in reference memory:*

- Press **SAVE/RECALL WAVEFORM**; then press the main-menu button **Save Wfm Ch 1**.
 - Press the side-menu button **To Ref 1** to save the probe compensation signal in reference 1.
 - Disconnect the cable from **CH 1** and the clips from the probe compensation terminals.
 - Press **MORE**; then press the main-menu button **Ref 1** to displayed the stored signal.
 - Press **CH 1**.
- d. *Hook up the DC standard source:*
- Set the output of a DC calibration generator to 0 volts.
 - Connect the output of a DC calibration generator through a dual-banana connector followed by a 50 Ω precision coaxial cable to one side of a BNC T connector. See Figure 4–23.
 - Connect the Sense output of the generator through a second dual-banana connector followed by a 50 Ω precision coaxial cable to the other side of the BNC T connector. Now connect the BNC T connector to **CH 1**. See Figure 4–23.

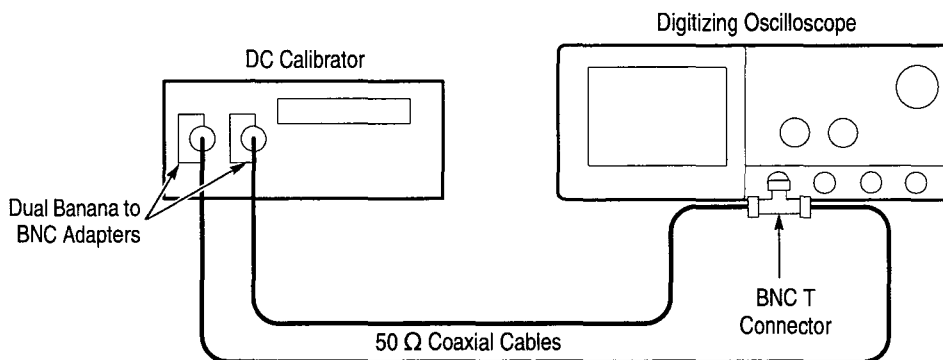

Figure 4–23: Subsequent Test Hookup

- e. *Measure amplitude of the probe compensation signal:*
- Press **SHIFT**; then press **ACQUIRE MENU**. Press the side-menu button **AVERAGE** then enter 16 using the keypad or the general purpose knob.

- Adjust the output of the DC calibration generator until it precisely overlaps the top (upper) level of the stored probe compensation signal. (This value will be near 500 mV.)
 - Record the setting of the DC generator.
 - Adjust the output of the DC calibration generator until it precisely overlaps the base (lower) level of the stored probe compensation signal. (This value will be near zero volts.)
 - Record the setting of the DC generator.
- f. Press **CLEAR MENU** to remove the menus from the display. See Figure 4–24.

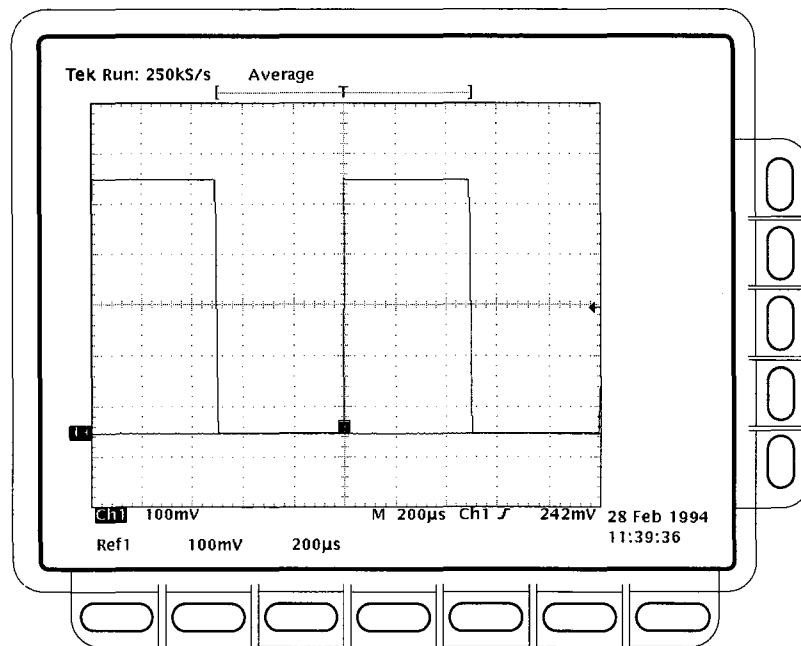

Figure 4–24: Measurement of Probe Compensator Amplitude

g. *Check against limits:*

- Subtract the value just obtained (base level) from that obtained previously (top level).
- CHECK that the difference obtained is within 495 mV to 505 mV, inclusive.
- Enter voltage difference on test record.

3. *Disconnect the hookup:* Disconnect the cable from **CH 1**.

Option 05 Video Trigger Checks

Check Video Trigger

Equipment Required	PAL signal source (Item 16) 60 Hz. sine wave generator (Item 17) Pulse generator (Item 18) Two 75 Ω cables (Item 19) Two 75 Ω terminators (Item 20) One BNC T connector (Item 7) 50 Ω cable (Item 5) 50 Ω terminator (Item 4)
Prerequisites	See page 4-15. These prerequisites include running the signal path compensation routine.

1. *Setup digitizing oscilloscope to factory defaults by completing the following steps:*
 - a. Press save/recall **SETUP**.
 - b. Press the main-menu **Recall Factory Setup**.
 - c. Press the side-menu **OK Confirm Factory Init**.
 - d. Wait for the Clock Icon to leave the screen.
 - e. CONFIRM the digitizing oscilloscope is setup as shown below.
 Channel: CH1
 Volt/div: 100 mV
 Horizontal scale: 500 μ s/div
2. *Setup digitizing oscilloscope for TV triggers by completing the following steps:*
 - a. Press **TRIGGER MENU**.
 - b. Press the main-menu **Type** pop-up until you select **Video**.
 - c. Press the main-menu **Standard** pop-up until you select **625/PAL**.
 - d. Press the main-menu **Line**.
 - e. Use the keypad to set the line number to 7 (press 7, then **ENTER**).
 - f. Press **VERTICAL MENU**.

- g. Press the main-menu **Bandwidth**.
 - h. Select **250 MHz** from the side menu.
 - i. Press the main-menu **Fine Scale**.
 - j. Use the keypad to set the fine scale to 282mV (press **282**, **SHIFT**, **m**, then **ENTER**).
 - k. Press **HORIZONTAL MENU**.
 - l. Press the main-menu **Horiz Scale**.
 - m. Use the keypad to set the horizontal scale to 200 ns (press **200**, **SHIFT**, **n**, then **ENTER**).
3. *Check Jitter vs. Signal Amplitude*
- a. Setup equipment for Jitter Test. See Figure 4–25.
 - Connect one of the rear panel composite outputs marked **COMPST** on the TSG121 through a 75 Ω cable and a 75 Ω terminator to the CH1 input of the TDS.
 - Press the **100% FIELD** control (the fourth TSG121 front-panel button from the left) of the PAL signal source.

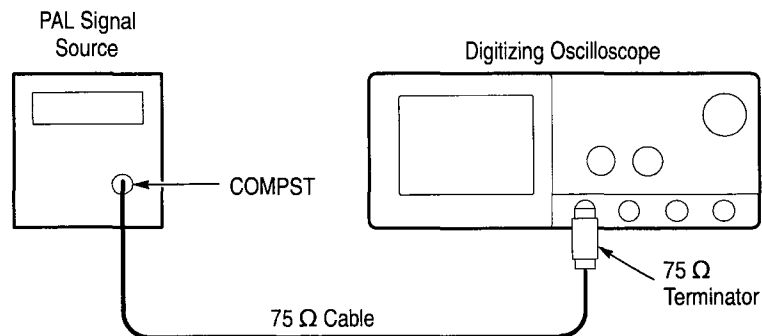

Figure 4–25: Jitter Test Hookup

- b. CHECK that the oscilloscope lights up its front panel **TRIG'D** LED and it displays the waveform on screen. See Figure 4–26.

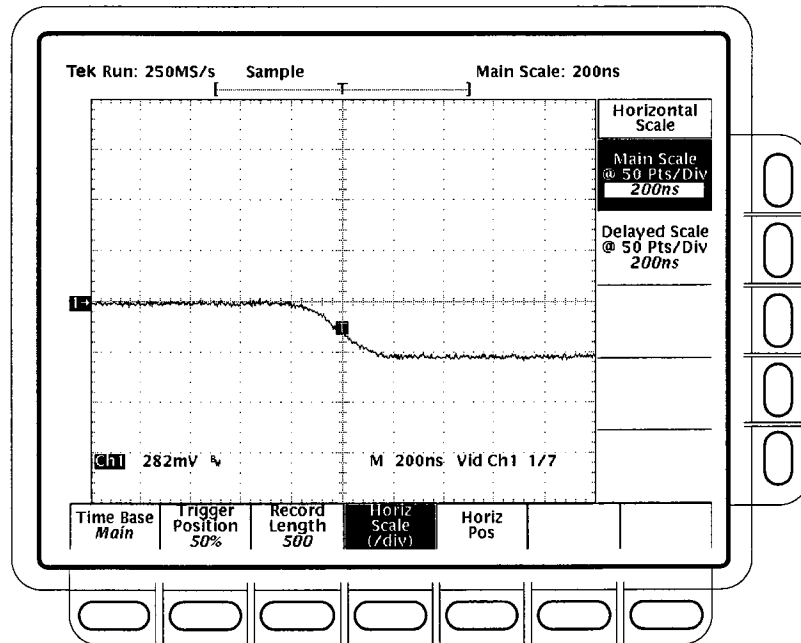

Figure 4-26: Jitter Test Displayed Waveform

- c. Press **SHIFT**; then press **ACQUIRE MENU**.
- d. Press the main-menu **Mode**.
- e. Select the side-menu **Average**. It should be already set to 16.
- f. Press the main-menu **Create Limit Test Template**.
- g. Press the side-menu **V Limit**.
- h. Use the keypad to set V Limit to 180 mdiv (press **180**, **SHIFT**, **m**, then **ENTER**)
- i. Press the side-menu **OK Store Template**.
- j. Press **MORE**.
- k. Press the main-menu **Ref1**.
- l. Press **CH1**.
- m. Press **SHIFT**; then press **ACQUIRE MENU**.
- n. Press the main-menu **Limit Test Setup**.
- o. Toggle the side-menu **Limit Test** to **ON**.
- p. Toggle the side-menu **Ring Bell if Condition Met** to **ON**.

- q. Press the main-menu **Mode**.
- r. Press the side-menu **Envelope**.
- s. Use the keypad to set envelope to use 100 acquisitions (press **100**, then **ENTER**).
- t. Press the main-menu **Stop After** button.
- u. Press the side-menu **Single Acquisition Sequence**.
- v. Confirm that the oscilloscope successfully makes 100 acquisitions. If not successful, the oscilloscope bell will ring. When the word **Run** in the top left corner of the display changes to **STOP**, the test is complete. See Figure 4-27.

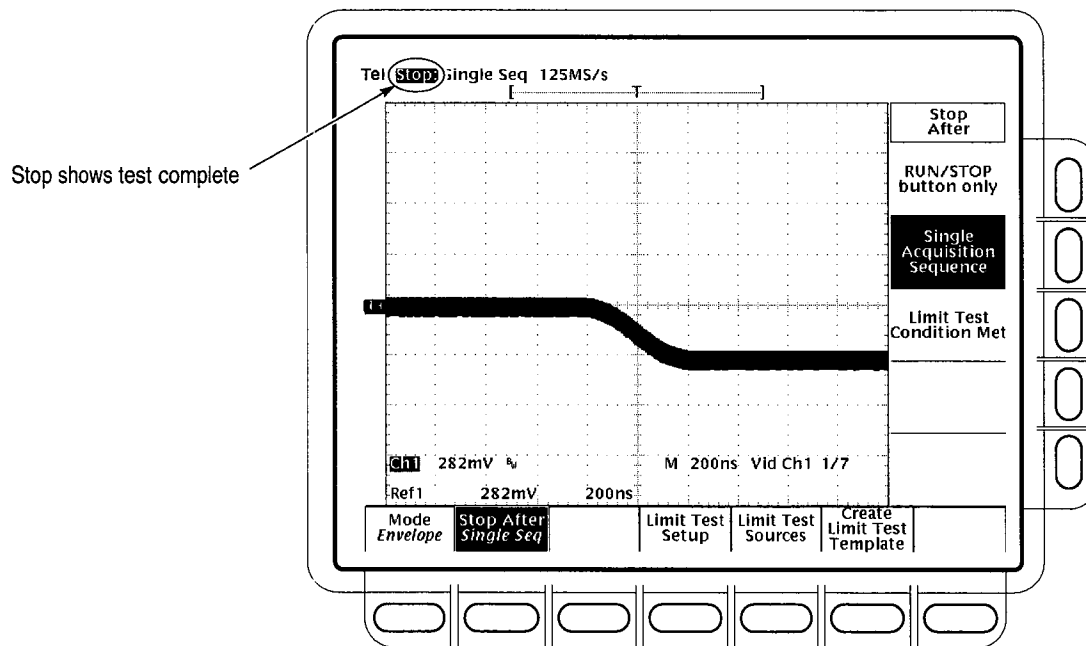

Figure 4-27: Jitter Test When Completed – TDS 684A Shown

- w. Press the main-menu **Limit Test Setup**.
 - x. Toggle the side-menu **Ring Bell if Condition Met** to **OFF**.
 - y. Toggle the side-menu **Limit Test** to **OFF**.
4. *Check Triggered Signal Range.*
- Setup oscilloscope for Triggered Signal Test.
- a. Press **MORE**.

- b. Press **WAVEFORM OFF**.
- c. Press **HORIZONTAL MENU**.
- d. Use the keypad to set horizontal scale (/div) to 50 μ s (press **50**, **SHIFT**, **μ** , then **ENTER**).
- e. Press **SHIFT**; then press **ACQUIRE MENU**.
- f. Press the main-menu **Stop After**.
- g. Press the side-menu **RUN/STOP button only**.
- h. Press the main-menu **Mode**.
- i. Press the side-menu **Sample**.
- j. Press **RUN/STOP**.
- k. Press **VERTICAL MENU**.
- l. Use the keypad to set fine scale to 300 mV (press **300**, **SHIFT**, **m**, then **ENTER**).
- m. **CONFIRM** that the **TRIG'D LED** stays lit and that the waveform on screen is stable. i.e.; does not move horizontally or vertically. Also, **CONFIRM** that the waveform on the screen has one positive pulse and a number of negative pulses. See Figure 4-28.

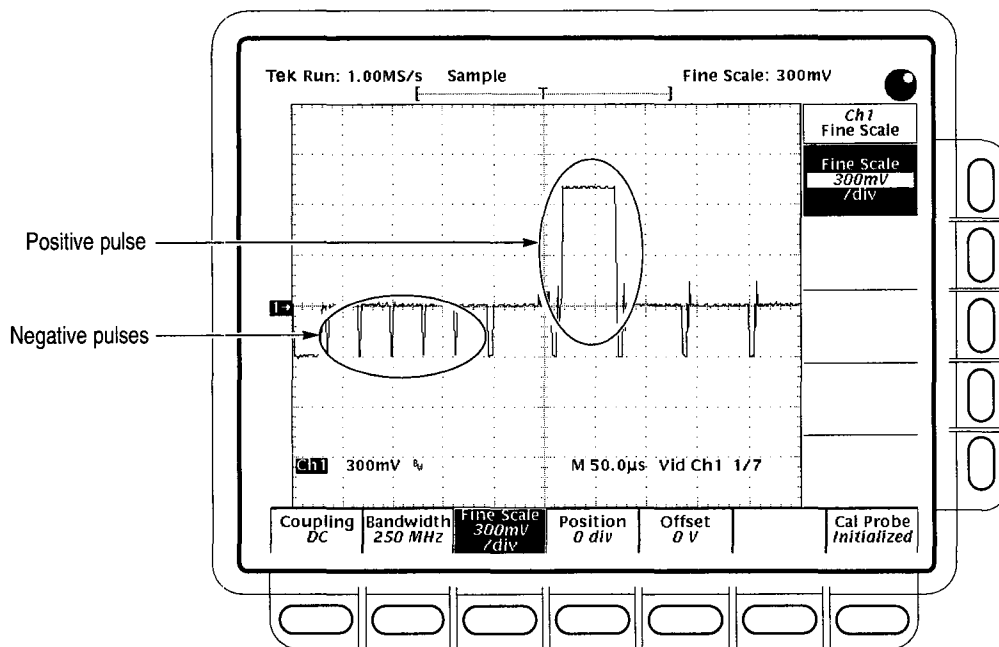

Figure 4-28: Triggered Signal Range Test – 300 mV

- n. Use the keypad to set the fine scale to 75 mV (press **75**, **SHIFT**, **m**, then **ENTER**).
- o. CONFIRM that the **TRIG'D** LED stays lit and that the waveform on screen is stable. i.e.; does not move horizontally or vertically. Also, CONFIRM that the waveform on the screen has one positive pulse and a number of negative pulses. See Figure 4-29.

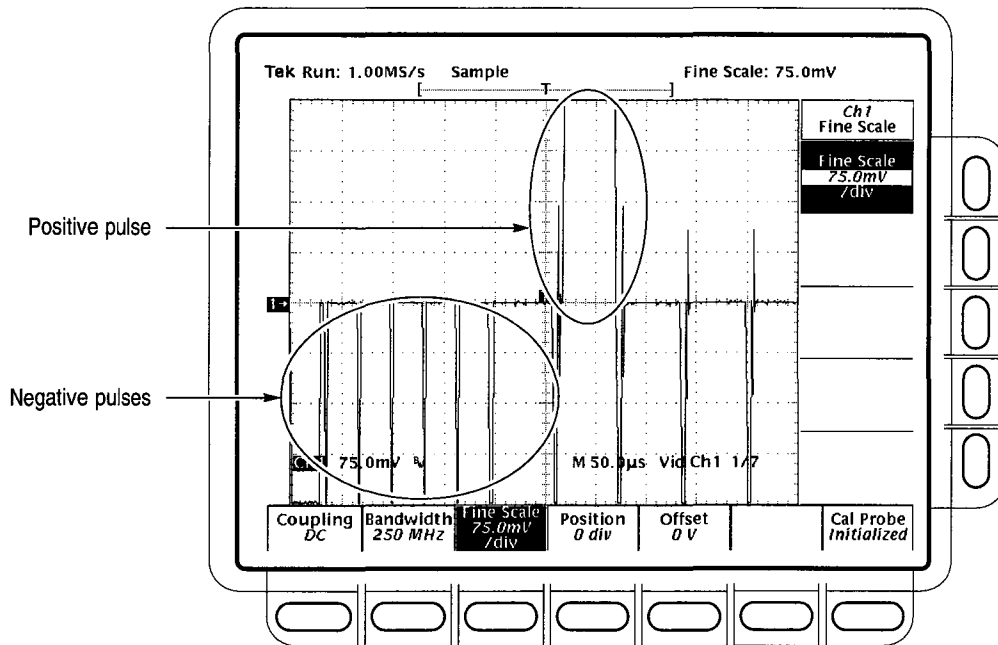

Figure 4-29: Triggered Signal Range Test – 75 mV

- p. Disconnect all test equipment (TSG121) from the digitizing oscilloscope.
5. *Check 60 Hz Rejection.*
- a. Setup oscilloscope for 60 Hz Rejection Test.
 - Use the keypad to set the Ch1 Fine Scale to 282 mV (press **282**, **SHIFT m**, then **ENTER**).
 - Press **WAVEFORM OFF**.
 - Press **CH2**.
 - Press **VERTICAL MENU**.
 - Use the keypad set the fine scale to 2 V (press **2**, then **ENTER**).
 - Press **HORIZONTAL MENU**.
 - Use the keypad to set the horizontal scale (/div) to 5 ms (press **5**, **SHIFT, m**, then **ENTER**).
 - b. Setup 60 Hz signal generator (SG 502).
 - Connect the output of the SG 502 to the CH2 input through a 50 Ω cable. See Figure 4-30.

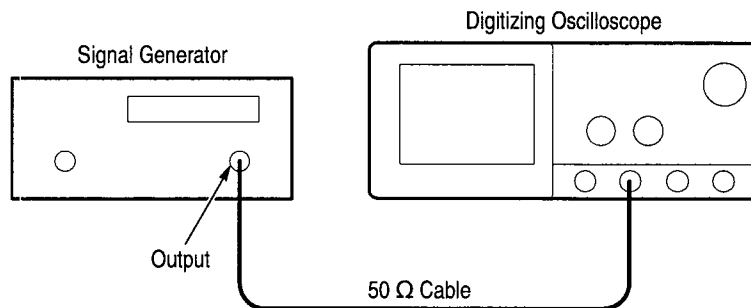

Figure 4-30: 60 Hz Rejection Test Hookup

- Adjust the SG 502 for three vertical divisions of 60 Hz signal. See Figure 4-31. The signal will not be triggered. That is, it will run free.

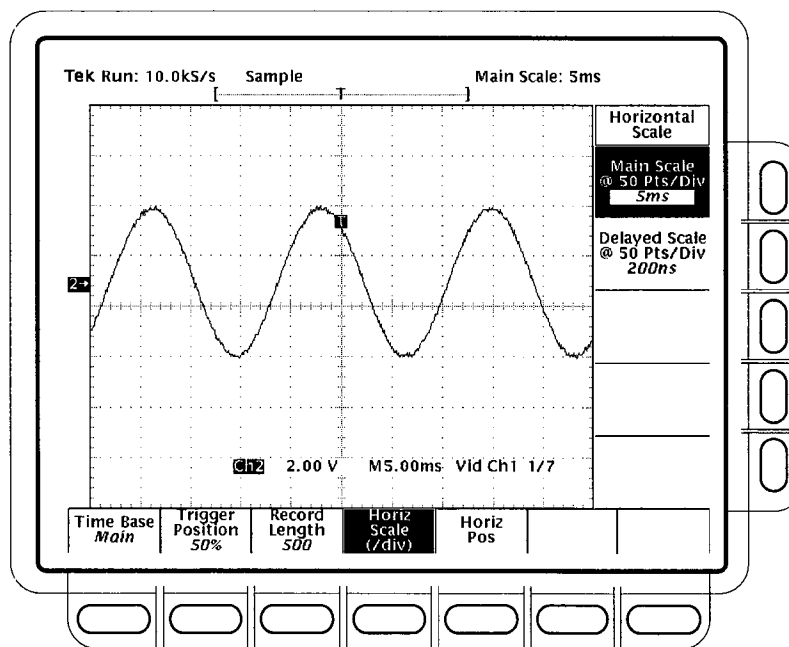

Figure 4-31: 60 Hz Rejection Test Setup Signal

- Check 60 Hz rejection.
 - Use the keypad to set the horizontal scale (/div) to 50 μ s (press **50**, **SHIFT**, **μ** , then **ENTER**).
 - Reconnect the output of the signal generator (SG 502). Connect the composite signal connector of the PAL signal source (labeled

COMPST on the TSG 121) to a 75 Ω cable and a 75 Ω terminator. Connect both signals to the CH1 input through a BNC T. See Figure 4–32.

- Press **VERTICAL MENU**.
- If needed, press the main-menu **Fine Scale**.
- Use the keypad to set fine scale to 500 mV (press **500**, **SHIFT**, **m**, then **ENTER**).
- Connect another composite signal connector of the PAL signal source (labeled **COMPST** on the TSG 121) through a 75 Ω cable and a 75 Ω terminator to the CH2 input. See Figure 4–32.

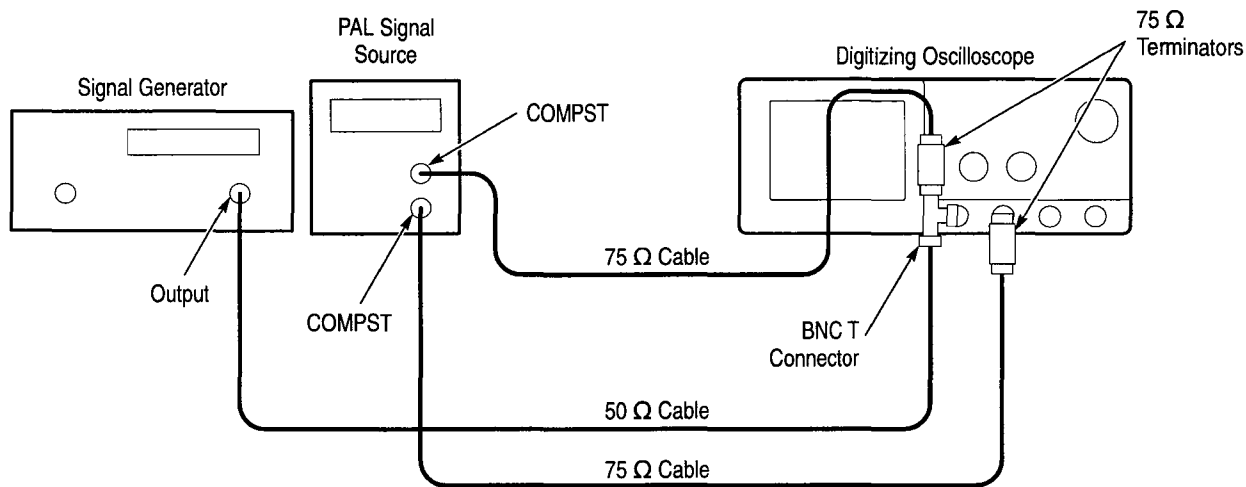

Figure 4–32: Subsequent 60 Hz Rejection Test Hookup

- **CONFIRM** that the **TRIG'D** LED stays lit and that the waveform on screen is stable. In other words, be sure the waveform does not move horizontally or vertically. Also, confirm that the waveform on the screen has one positive pulse and a number of negative pulses. See Figure 4–33.

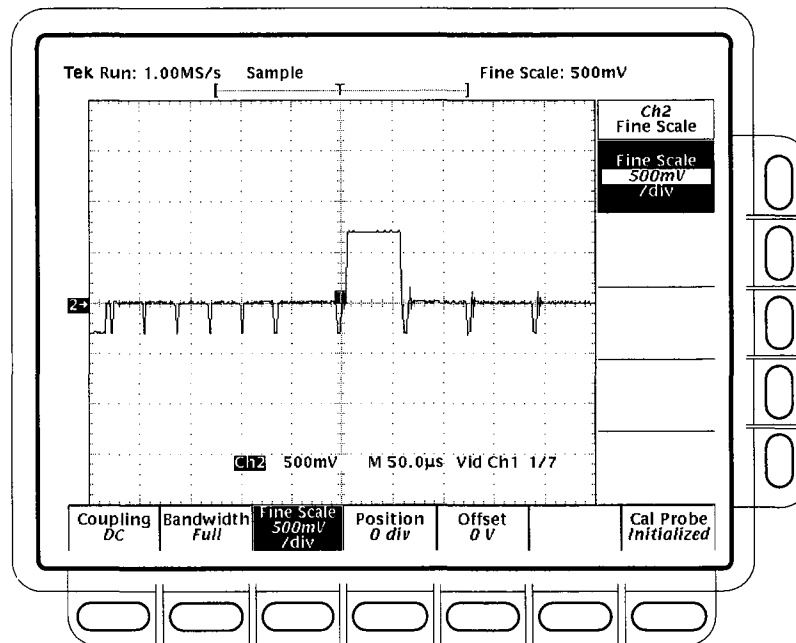

Figure 4-33: 60 Hz Rejection Test Result – TDS 684A Shown

- Disconnect all test equipment from the digitizing oscilloscope.
- 6. *Check Line Count Accuracy.*
 - a. Setup oscilloscope for Line Count Accuracy Test.
 - Press **WAVEFORM OFF**.
 - Press **CH1**.
 - Press **HORIZONTAL MENU**.
 - Press the main-menu **Record Length**.
 - Press the side-menu **–more–** until you see the appropriate menu.
 - Press the side-menu **5000 points in 100divs**.
 - Press the main-menu **Horiz Scale (/div)**.
 - Use the keypad to set the horizontal scale to 200 ns (press **200**, **SHIFT**, **n**, then **ENTER**).
 - b. Check Line Count Accuracy.
 - Connect a composite output signal from the rear of the PAL signal source (labelled **COMPST** on the TSG 121) to the CH1 input through a 75 Ω cable and a 75 Ω terminator. See Figure 4-34.

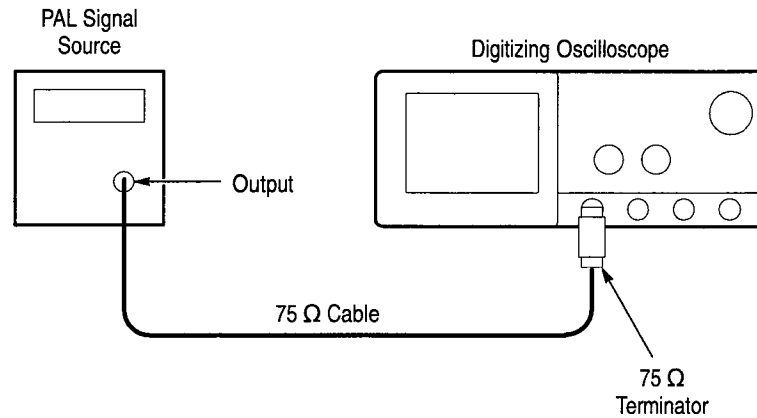

Figure 4-34: Line Count Accuracy Test Hookup

- Press the main-menu **Trigger Position**.
- Press the side-menu to **Set to 50%**.
- Press the main-menu to **Horiz Pos**.
- Press the side-menu to **Set to 50%**.
- Use the **HORIZONTAL POSITION** knob to move the falling edge of the sync pulse to two divisions to the left of center screen. See Figure 4-35.

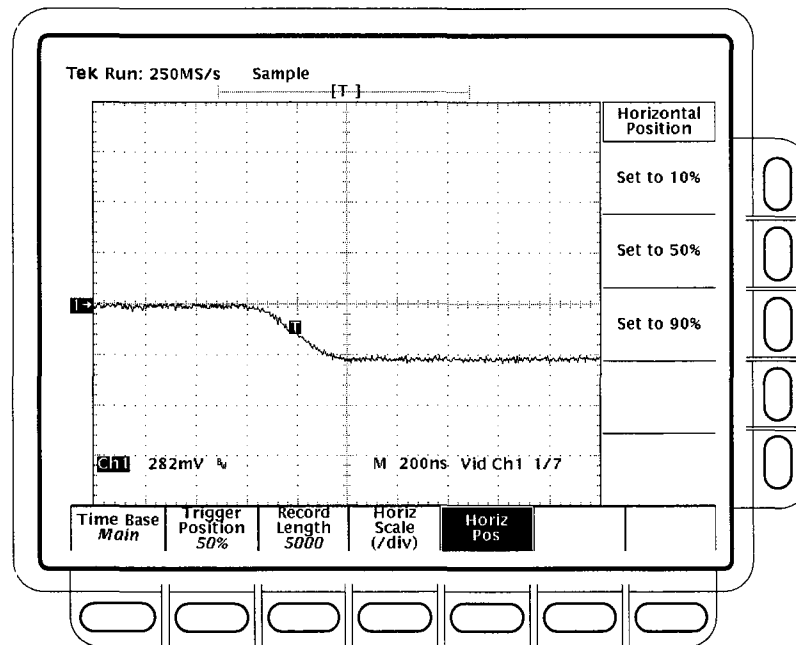

Figure 4-35: Line Count Accuracy Test Setup Waveform – TDS 684A Shown

- Press **CURSOR**.
- Press the main-menu **Function**.
- Press the side-menu **V Bars**.
- Using the General Purpose knob, place the left cursor directly over the trigger 'T' icon.
- Press **SELECT**.
- Turn the General Purpose knob to adjust the right cursor for a cursor delta reading of **6.780us**.
- Use the **HORIZONTAL POSITION** knob to position the right cursor to center screen.
- Verify that the cursor is positioned on a positive slope of the burst signal. See Figure 4-36.

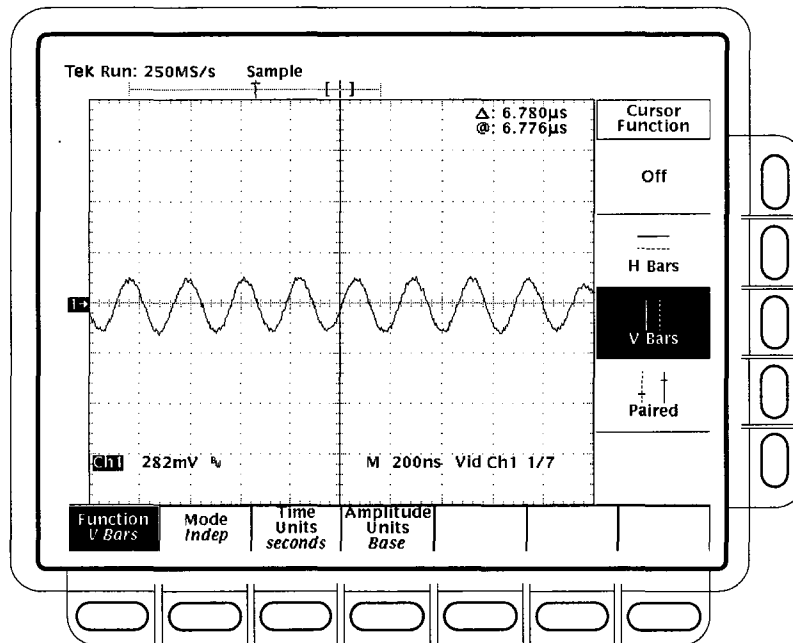

Figure 4-36: Line Count Accuracy Correct Result Waveform

- Disconnect all test equipment (TSG 121) from the digitizing oscilloscope.
- Turn off cursors by pressing **CURSOR**, then the main-menu **Function** button, and, finally, **Off** from the side menu.

7. Check the Sync Duty Cycle.

a. Setup digitizing oscilloscope for Sync Duty Cycle Test.

- Press **TRIGGER MENU**.
- Press the **Standard** pop-up to select **FlexFmt**. (Trigger **Type** should already be set to **Video**)
- Press the main-menu **Setup**.
- Press the side-menu **Field Rate**.
- Use the keypad to set the field rate to 60.05 Hz (press **60.05**, then **ENTER**).
- Press the side-menu **Lines**.
- Use the keypad to set the field rate to 793 lines (press **793**, then **ENTER**).

- Press the side-menu **Fields**.
 - Use the keypad to set the number of fields to 1 (press **1**, then **ENTER**).
 - Press the side-menu **Sync Width**.
 - Use the keypad to set the width to 400 ns (press **400**, **SHIFT**, **n**, then **ENTER**).
 - Press the side-menu **–more– 1 of 2**. Then press **V1 Start Time**.
 - Use the keypad to set V1 start time to 10.10 μ s (press **10.10**, **SHIFT**, **μ** , then **ENTER**).
 - Press the side-menu **V1 Stop Time**.
 - Use the keypad to set V1 stop time to 10.50 μ s (press **10.50**, **SHIFT**, **μ** , then **ENTER**).
 - Press the main-menu **Type** pop-up to select **Edge**.
 - Press **HORIZONTAL MENU**.
 - Press the main-menu **Record Length**.
 - Select the side-menu **1000 points in 20div**. If needed, first press the side-menu **–more–** until you see the appropriate side-menu item.
 - Turn the **HORIZONTAL POSITION** knob to position the trigger 'T' two divisions to the left of the center screen.
 - Press **MEASURE**.
 - If needed, press the main-menu **Select Measrmnt**.
 - Press the side-menu **Negative Width**.
 - Press the side-menu **Period**.
- b. Setup the pulse generator (PG502) for Sync Duty Cycle Test.
- Set **PULSE DURATION** to 50 ns.
 - Set **PERIOD** to 10 μ s.
 - Set **OUTPUT (VOLTS)** to **–1** for **LOW LEVEL** and **+1** for **HIGH LEVEL**.
 - Depress the **COMPLEMENT** button.
 - Be sure **BACK TERM** is depressed (in).

c. Check Sync Duty Cycle.

- Connect the pulse generator (PG502) through a 50 Ω cable and a 50 Ω terminator to the oscilloscope CH1 input. See Figure 4-37.

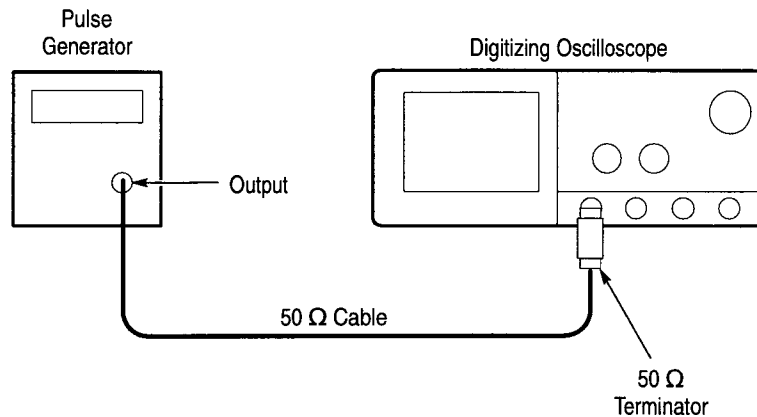

Figure 4-37: PG502 Setup for Sync Duty Cycle Test

- Turn the pulse generator **OUTPUT (VOLTS)** control until the signal on the oscilloscope shows a one division negative going pulse. See Figure 4-38.

NOTE. *You may need to adjust the trigger level control to obtain a stable trigger.*

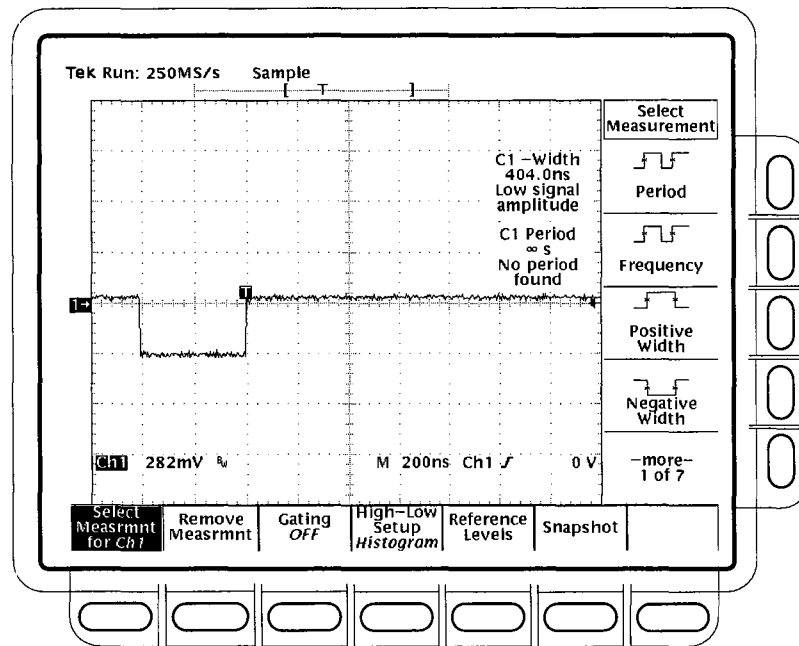

Figure 4-38: Sync Duty Cycle Test: One-Div Neg Pulse Waveform

- Turn the pulse generator **PULSE DURATION** variable control to adjust the negative pulse so the oscilloscope's **CH1 - Width** measurement displays **400ns +/-10 ns**.
- Turn the **HORIZONTAL SCALE** knob to set the oscilloscope time base to **5µs/div**.
- Turn the pulse generator **PERIOD** variable control to adjust the period until the oscilloscope **CH1 Period** measurement reads **21.000µs -25/+50 ns**. See Figure 4-39. Read note shown below.

NOTE. The pulse duration and period adjustments are critical in making this measurement. If the pulse duration and/or the duty cycle are not stable, the **FLEXFMT** function may not function. You must take care when making these adjustments.

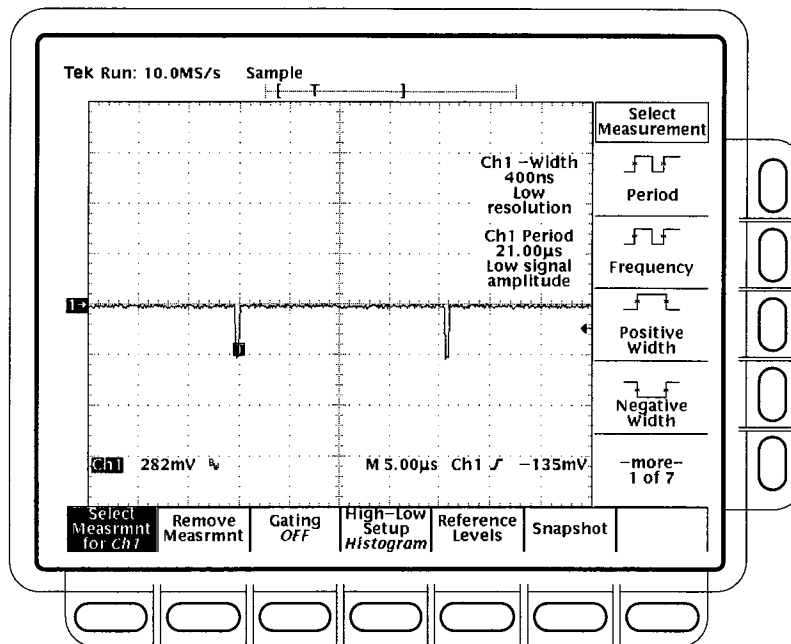

Figure 4-39: Sync Duty Cycle Test: Critically Adjusted Pulse

- Press **TRIGGER MENU**.
- Press the main-menu **Type** pop-up until you select **Video**.
If the **TRIG'D** LED is not lit, check that the **CH1 – Width** and **CH1 Period** measurements are adjusted correctly. See note above. CONFIRM that the setup is correct and the oscilloscope will trigger.
- CONFIRM that the **TRIG'D** LED is lit and the waveform is stable.
- Disconnect the signal source from CH1, wait a few seconds, then reconnect the signal.
- CONFIRM that the **TRIG'D** LED is lit and the waveform is stable.
- Press **Sync Polarity**.
- Press **Pos Sync**.
- Push the pulse generator **COMPLEMENT** button out.
- CONFIRM that the **TRIG'D** LED is lit and the waveform is stable.
- Disconnect the signal source from CH1, wait a few seconds, then reconnect the signal.
- CONFIRM that the **TRIG'D** LED is lit and the waveform is stable.

- Disconnect all test equipment (TSG 121) from the digitizing oscilloscope.
- Press save/recall **SETUP**, press the main-menu button **Recall Factory Setup**, and the side-menu **OK Confirm Factory Init**.

Performance Tests



Adjustment Procedures

This section contains information needed to adjust the TDS 684A and 744 Digitizing Oscilloscopes.

- Description** The *Adjustment Procedures* are divided into six subsections:
- General information about adjusting the TDS 684A and 744 Digitizing Oscilloscopes.
 - A list of equipment required to perform the adjustments.
 - The written procedures for installing and using both the *TDS 684A Adjustment Software* and the *TDS 744 Adjustment Software*.
 - The TDS 684A and the TDS 744 *Adjustment Software* (two disks) included with this manual. The material found in the subsections listed above should be read before using the adjustment software.
 - A written procedure for manually adjusting the optional P6139A probe.
 - A written procedure for manually adjusting the display assembly.

Purpose This procedure is used to return the digitizing oscilloscope to conformance with its *Warranted Characteristics* as listed in Section 1, *Specification*. It can also be used to optimize the performance of the oscilloscope.

Adjustment Interval As a general rule, these adjustments should be done every 2000 hours of operation or once a year if the oscilloscope is used infrequently.

Requirements for Performance

Before you do this procedure, you need to address the following requirements.

Personnel This procedure is only to be performed by trained service technicians.

Warm-Up Period This oscilloscope requires a 20 minute warm-up time in a 20° C to 30° C environment before it is adjusted. Adjustments done before the operating temperature has stabilized may cause errors in performance.

Access Except when adjusting the display assembly, the cabinet is not removed. Instead, you enable the internal adjustment constants of the oscilloscope to be written.

Two small holes in the chassis allow service personnel to insert a tool and push a switch to enable or disable the writing of new adjustment constants to non-volatile RAM.

The procedure that follows will tell you how and when to enable and disable the writing of adjustment constants. Be sure to disable the switch when you have finished adjusting the oscilloscope.

System The following computer and peripherals are required to adjust this oscilloscope.

An IBM® PC™ compatible computer equipped as follows:

- Eight MHz clock speed or faster.
- DOS 3.2 or higher.
- 640K Resident RAM with 580 K Available RAM.
- A hard drive.
- A high-density floppy drive: 3.5 inch (1.44 M) or 5.25 inch (1.2 M).
- A GPIB board — National Instruments® GPIB-PCII, GPIB-PCIIA or GPIB-PCII/IIA. (A PC-GPIB Package that includes the PCII/IIA is available — Tektronix part number S3FG210).
- Suitable keyboard and monitor.

Optional Peripherals Installation of a math coprocessor in your system is strongly recommended to decrease the time required to adjust the oscilloscope.

Test Equipment The equipment list, starting on page 5–5, lists all test equipment required to adjust this oscilloscope.

Usage

The following topics cover what is required of you when adjusting the oscilloscope and what is done by the software. Also, the performance of individual adjustments is discussed.

Performing the Adjustments When using the adjustment software, you will not be required to manually adjust any circuits. As you run the calibration tests, the software adjusts the circuits using external standards you provide in response to prompts on the computer screen. Your role, then, is to provide those test signals and to prompt the computer to continue.

Since the display-assembly and P6139A probe adjustment require manual adjustment of circuit components, they are not part of the adjustment software. Written procedures for these adjustments start on page 5–7.

If you are using the optional P6139A probe, do the manual adjustment procedures found at the end of this section.

Complete Adjustment

A complete adjustment is the performance of all adjustments on the *TDS 684A Adjustment Software* and the *TDS 744 Adjustment Software*, in sequence, plus the P6139A probe adjustment (if you are using the P6139A probe).

Throughout this section, “complete adjustment” is used as just defined.

Individual Adjustments

The adjustment software contains three classes of adjustments as shown in Table 5–1. Each class contains one or more individual calibration tests (CATS) and an internal compensation routine (SPC). The *Adjustment Software* provides you with instructions for running each of the tests.

All these software-based adjustments are made internally by the adjustment software, and all adjustments can be done without removal of the oscilloscope cabinet.

Signal Path Compensation (SPC). This internal routine is not an adjustment. It is a temperature compensation routine that compensates for the current operating temperature to optimize oscilloscope performance.

Table 5–1: Calibration Tests

Class of Adjustment	CATS Tests
Voltage Reference	CVR_CAL TEMPERATURE_SET SPC
Frequency Response	SPC HF_CAL
Pulse Trigger	SPC TRIG_POS_CAL PNP_LATENCY GLITCH_TRIG_CAL

Partial Adjustment

The adjustment software will allow you to make individual adjustments. However, usually all adjustments are made unless you are adjusting circuits in the course of troubleshooting the oscilloscope. Read the information under *Complete Adjustment*, *Adjustment After Repair*, and *Adjustment Dependencies* before doing an individual adjustment.

Adjustment Procedures

Adjustment After Repair

After the removal and replacement of a module due to electrical failure, you must either do a complete adjustment or no adjustment at all, depending on the module replaced. See Table 5–2.

Table 5–2: Adjustments Required for Module Replaced

Module Replaced	Adjustment Required
Acquisition Board	Complete Adjustment
Front Panel Assembly	None Required
Low Voltage Power Supply	None Required
Processor Board	None Required
Display Assembly	Display Adjustment Only

Adjustment Dependencies

Some adjustments depend on successful prior completion of other adjustments. For example, all the CATS tests associated with the Voltage Reference Adjustment class must be passed before any other adjustments can be successfully completed. Table 5–3 lists the adjustments and their dependencies.

Table 5–3: Adjustments and Dependencies

Class of Adjustment	Prior Completion Requirements
Voltage Reference Adjustment	None
Frequency Response Adjustment	Voltage Reference (SPC and all tests)
Pulse Trigger Adjustment	Voltage Reference (SPC and all tests)
P6139A Probe Adjustment	Voltage Reference and Frequency Response (SPC and all tests)
Display Adjustment	None

Equipment Required

Table 5–4 lists the test equipment required to adjust the TDS 684A and 744 Digitizing Oscilloscopes.

Table 5–4: Test Equipment, Fixtures, and Supplies

Item Number and Description	Minimum Requirements	Example	Purpose
1. Adapter, BNC-Female-to-BNC-Female	Tektronix part number 013-0028-00	Tektronix part number 013-0028-00	Probe Adjustment
2. Adapter, Probe Tip to BNC, 50 Ω termination	Tektronix part number 013-0227-00	Tektronix part number 013-0227-00	Probe Adjustment
3. Adjustment Tool	Less than 1/8 inch diameter and over 2 inches long	Tektronix part number 003-0675-00	Software-based Adjustments (used as a probe) and Manual Adjustments
4. Adjustment Tool	7/32 inch hex wrench on both ends	GC Electronics #8606	A30 CRT Driver adjustment
5. Attenuator, 10X (Two required)	Ratio: 10X; impedance 50 Ω ; connectors: female BNC input, male BNC output	Tektronix part number 011-0059-02	Software-based Adjustments
6. Attenuator, 2X	Ratio: 2X; impedance 50 Ω ; connectors: female BNC input, male BNC output	Tektronix part number 011-0069-02	Software-based Adjustments
7. Cable GPIB	IEEE Std 488.1–1987/ IEEE Std 488.2–1987	Tektronix part number 002-0991-01	Software-based Adjustments
8. Coupler, Dual-Input		Tektronix part number 067-0525-02	Software-based Adjustments
9. Cable, Precision Coaxial	50 Ω , 36 in, male to male BNC connectors	Tektronix part number 012-0482-00	Software-based Adjustments
10. Connector, Dual-Banana	Female BNC to dual banana	Tektronix part number 103-0090-00	Software-based Adjustments
11. Generator, Calibration	High Amplitude pulse with variable amplitude of at least 60 V.	Tektronix PG 506A ¹ Calibration Generator	Probe Adjustment
12. Generator, DC Calibration	Variable amplitude to ± 104 V; accuracy to 0.1%	Data Precision 8200	Software-based Adjustments
13. Generator, Leveled Sine Wave, Medium-Frequency	200 kHz to 250 MHz; Variable amplitude from 5 mV to 4 V _{p-p} into 50 Ω ; flatness ≤ 3 %; harmonic content: 2 nd harmonic down –30 dB from fundamental; all others down –40 dB	Tektronix SG 503 ¹ or SG5030 ¹ Leveled Sine Wave Generator	Software-based Adjustments

Adjustment Procedures

Table 5-4: Test Equipment, Fixtures, and Supplies (Cont.)

Item Number and Description	Minimum Requirements	Example	Purpose
14. Generator, Leveled Sine Wave, High-Frequency	250 MHz to 1 GHz; Variable amplitude from 0.5 V to 4 V _{p-p} into 50 Ω; 6 MHz reference; harmonic content: 2 nd harmonic down -25 dB from fundamental; all others down -40 dB	Tektronix SG 504 ¹ Leveled Sine Wave Generator with its leveling head or a Tektronix SG 5030 ¹ Programmable Leveled Sine Wave Generator with its leveling head	Software-based Adjustments
15. Magnifier, 6X	Standard Tool		Brightness and Focus Adjustment
16. Photometer	0.1 to 200 Footlamberts	Tektronix J16 Photometer with J6503 Luminance Probe	Contrast Adjustment
17. Probe, 10X, optional accessory	A P6139A Probe	Tektronix P6139A	Probe Adjustment
18. Multimeter, Digital	200 V, ±0.05% Accuracy	Tektronix DM504A Digital Multimeter ¹	A30 CRT Driver Adjustment
19. Fixture, Display Holding		Tektronix part number 067-0211-00	Display Adjustment
20. Fixture, Raster-Center Locating		Tektronix part number 067-0208-00	Locating Center of Display
21. Adhesive	Non-corrosive RTV silicon rubber paste	RTV #3145, Tektronix part number 006-1171-00	Fixing Adjustments and Components
22. Adhesive	Non-corrosive	Loctite Assure #42540	Fixing Adjustments
23. Adhesive	Non-corrosive	TRA-CON Tra-Bond #BA-2114	Fixing BNC
24. Graticule, External		Tektronix part number 067-0206-00	A30 CRT Driver Linearity Check
25. Extension Cable	18 inch, 16 pin	Tektronix part number 174-2655-00	A30 CRT Driver Adjustment
26. Screwdriver, Torque	Standard Tool		CRT Yoke Adjustment
27. Magnets, Horizontal Linearity	0.59 × 0.59 × 0.09, 4-20 Gauss	Tektronix part number 119-1616-00	Horizontal Linearity Adjustment
28. Strap, Nylon	8.0 × 0.1 Nylon	Tektronix part number 346-0128-00	Horizontal Linearity Adjustment
29. Pulser, Tunnel Diode	Tektronix part number 067-0681-01	Tektronix part number 067-0681-01	Probe Adjustment

¹ Requires a TM 500 or TM5000 Series Power Module Mainframe.

Adjustment Instructions

The following instructions describe installing the software on your system, setting up the oscilloscope for adjustment, and starting the adjustment of the oscilloscope by the software.

Hardware Installation

1. *Install the proper GPIB card (see System on page 5-2):* Use the manual accompanying your GPIB card to install and configure that card.
2. *Configure the GPIB card:*
 - a. This software is compatible with cards configured for PCII and PCIIA operation. The following table lists the default card settings.
 - b. If these settings conflict with your hardware setup, see your GPIB card manual for alternate settings.
 - c. If you have more than one GPIB card installed, this adjustment software assumes the first card (referenced 0). See your GPIB card manual for information on how to determine which card is your "0" card.

Table 5-5: GPIB Board Configuration¹

Board Settings	GPIB-PCII	GPIB-PCIIA
Base I/O Address (hex)	2B8	2E1
Interrupt Line	7	7
DMA Channel	1	1

¹ **Systems using the combination card (GPIB-PCII/IIA) can be configured as either a GPIB-PCII or a GPIB-PCIIA.**

Software Installation

STOP. ALWAYS use this installation procedure when installing this software on a new computer. This installation program uses parameters you supply (see step 2, substep a) to create a custom start-up file on your hard disk directory. After installation, the software will instruct you to run this start-up batch file whenever you do software-based adjustments, so it can configure your computer properly before it runs the adjustment program. Do not simply copy the software files from one computer to another, since the start-up batch file you copy may not match the computer you copy it to.

1. *Create a working disk:* Using the proper DOS commands, copy the Adjustment Software disk to a working disk.

2. *Install the software to hard disk:*
 - a. Install your working disk in a floppy drive and type *install*. The software will ask you to specify the hard disk on which to install the adjustment software. It will also prompt you to specify several GPIB-card configuration parameters.
 - b. The adjustment software will be installed in a directory called *TDS684.ADJ* or *TDS744.ADJ* on your hard drive.
3. *Store your installation disk:* Remove your installation disk and store in a secure place.

Software-Based Adjustments

Equipment Required	All items that are listed for "Software-based Adjustments" under "Purpose" in Table 5-4 starting on page 5-5.
---------------------------	---

1. *Hook up the oscilloscope:*
 - a. Connect the GPIB cable (Item 7) to the GPIB port at the computer rear panel. (When multiple GPIB cards are installed, connect to the GPIB0 card.)
 - b. Connect the GPIB cable (Item 7) to the GPIB port at the oscilloscope rear panel.
 - c. Power on the oscilloscope.
2. *Set up the oscilloscope:*
 - a. Press **SHIFT**; then press **UTILITY**.
 - b. Repeatedly press the main-menu button **System** until **I/O** is highlighted in the pop-up menu.
 - c. Press the side-menu button **TALK/LISTEN**.
 - d. Use the keypad to set any address between 0 and 29.
3. *Enable the adjustment constants to be written:*
 - a. Locate the two small access holes on the right side of the oscilloscope cabinet near the front.
 - b. Insert the adjustment tool (Item 3) in the hole nearest the front of the oscilloscope about 1/2 inch to engage the rocker switch.
 - c. Push to rock the switch to its unprotected (enabled) position. See Figure 5-1.
 - d. Type ADJ684A for the TDS 684A or type ADJ744 for the TDS 744..

- e. Follow the instructions as prompted on your computer screen.
4. *Let the oscilloscope warm up:* Allow a 20 minute warm-up period before you begin step 5.

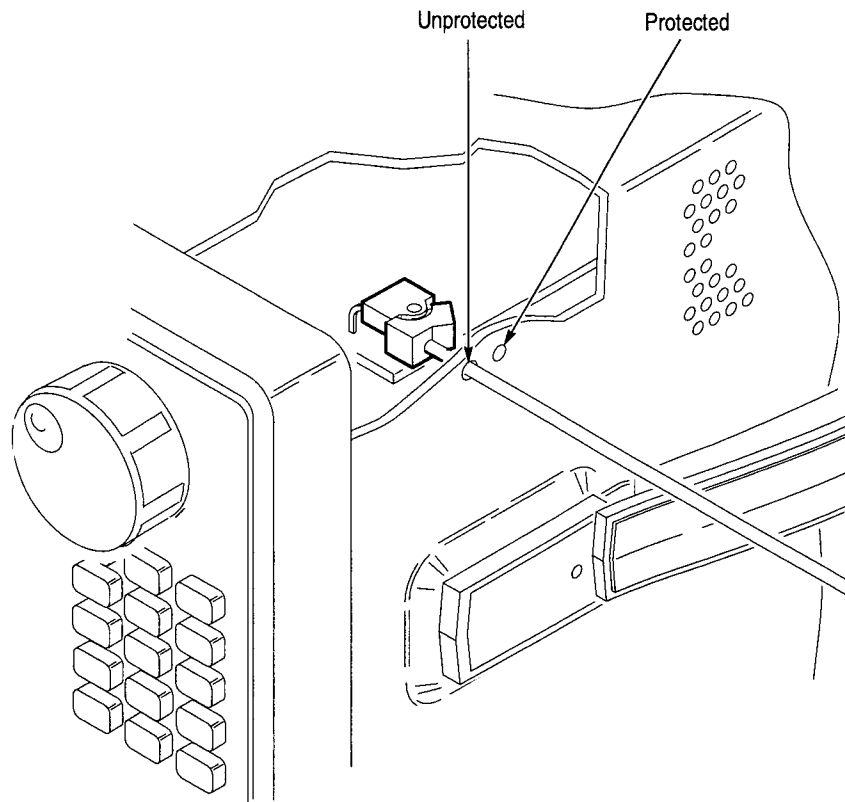

Figure 5-1: Accessing the Protection Switch

5. *Start the adjustment software:*
 - a. Change drives to your hard drive.
 - b. Change directories to TDS684A.ADJ for the TDS 684A or TDS744.ADJ for the TDS 744.
6. *When adjustment has been completed:*



CAUTION. Be sure to disable the NVRAM Protection switch as instructed below to protect the adjustment constants against alteration.

- a. Locate the two small access holes on the right side of the oscilloscope cabinet near the front. (See Figure 5-1.)

- b. Insert the adjustment tool (Item 3) in the hole nearest the *rear* of the oscilloscope about 1/2 inch to engage the rocker switch.
- c. Push to rock the switch to its protected (disabled) position.
- d. To do a complete adjustment as defined on page 5–3, you must also do the procedure *Compensate the Probe* on page 5–10 if you are using the optional P6139A probe.

Probe Adjustment for the P6139A Probe

STOP. It is not necessary to do this procedure to perform a complete adjustment unless you are using the optional P6139A probe.

This probe adjustment is divided into three parts: *Compensate the Probe*, *Measure the Probe Bandwidth*, and *Adjust the Probe — High Frequency Response*. If probe bandwidth is within required limits, you will be instructed to *not* do the high frequency response adjustment.

Compensate the Probe

Equipment Required	One P6139A probe (Item 17).
---------------------------	-----------------------------

1. Install the test hookup and preset the oscilloscope controls:

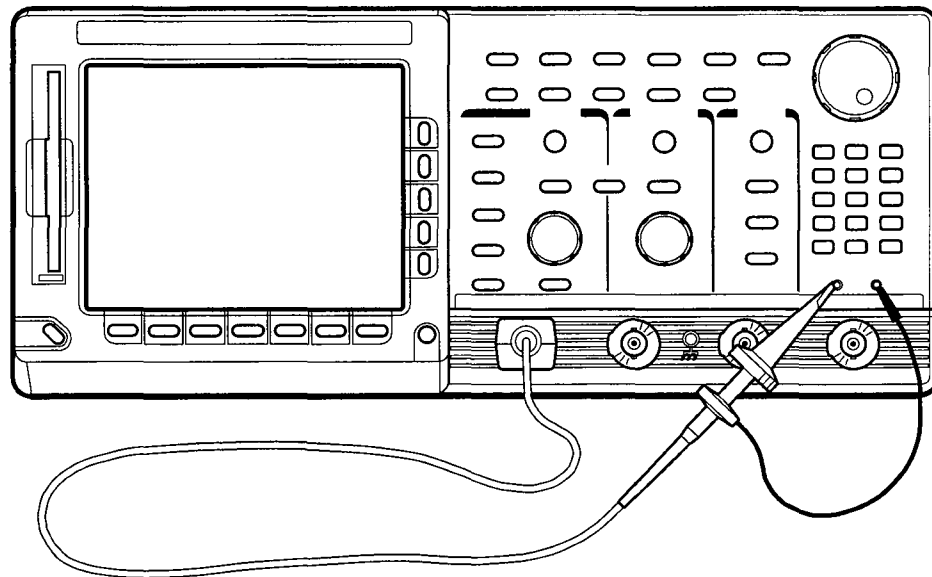

Figure 5–2: Hookup for Probe Compensation

- a. *Hook up test-signal source:* Install the optional-accessory probe to **CH 1**. Connect the probe tip to **PROBE COMPENSATION SIGNAL** on the front panel; connect the probe ground to **PROBE COMPENSATION GND**.
- b. *Initialize the oscilloscope:*
 - Press save/recall **SETUP**.
 - Press the main-menu button **Recall Factory Setup**.
 - Press the side-menu button **OK Confirm Factory Init**.
- c. *Modify the initialized front-panel control settings:*
 - Press **AUTOSET**. Set the horizontal **SCALE** to 250 μ s.
 - Press **SET LEVEL TO 50%** as required to trigger the signal.
 - Press **SHIFT**; then press **ACQUIRE MENU**.
 - Press the main-menu button **Mode**. Then press the side-menu button **Average 16**.

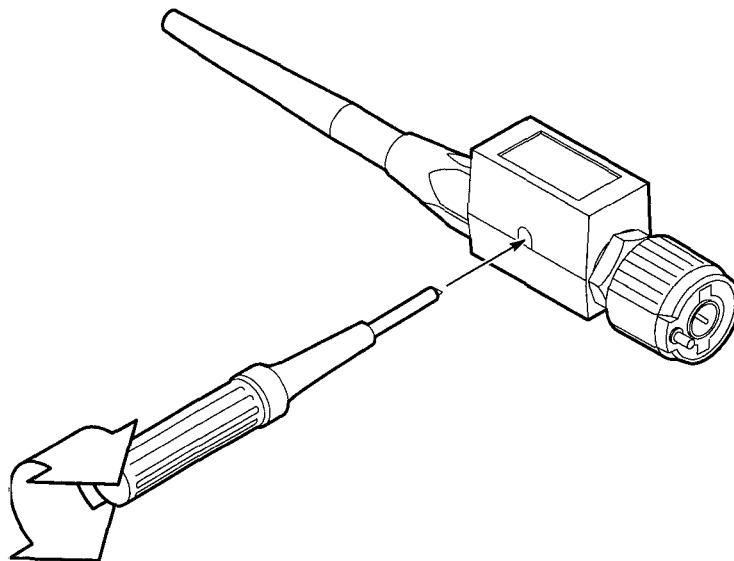

Figure 5-3: Performing Probe Compensation

2. *Compensate the Probe:*
 - a. Locate the probe compensation hole in the side of the probe body.

- b. Using the probe compensation tool, adjust the probe for best square wave compensation (flat as possible across its top).

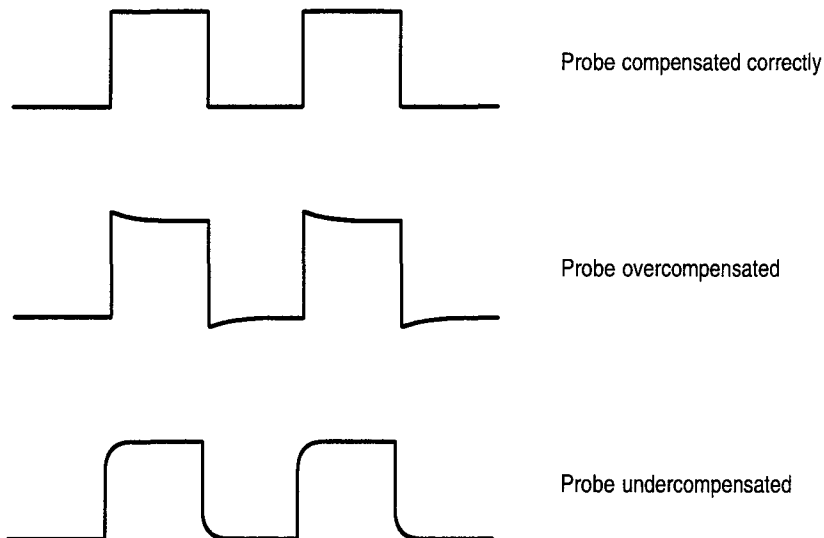

Figure 5-4: Proper and Improper Probe Compensation

3. *Disconnect the hookup:* Disconnect the probe from the probe compensator terminals; leave probe installed on CH 1 and leave the oscilloscope control setup as is for doing the next part of probe adjustment.

Measure Probe Bandwidth

Equipment Required	
	One high-frequency sine wave generator with its leveling head (Item 14)
	One BNC-female-to-female BNC adapter (Item 1)
	One BNC-to-probe tip adapter (Item 2)
	One P6139A 10X probe (Item 17)

1. *Install the test hookup and preset the oscilloscope controls:*
- a. *Expose the Inner Probe Tip:* Follow the instructions in Figure 5-5.

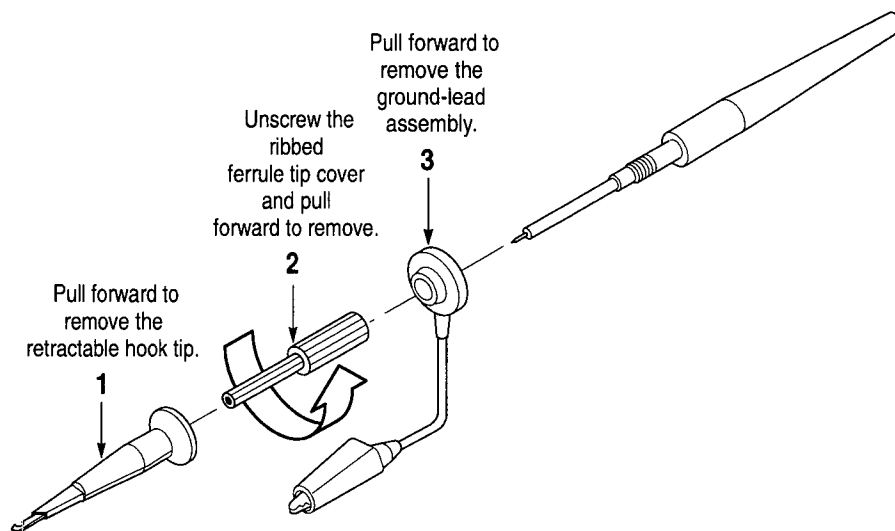

Figure 5-5: Exposing the Inner Probe Tip

b. Hook up test-signal source:

- Connect the output of a high-frequency sine wave generator, through its leveling head, to a female-to-female adapter. See Figure 5-6.
- Connect the female-to-female adapter to a BNC-to-probe tip adapter.
- Plug the probe tip from the probe on CH 1 into the BNC-to-probe tip adapter.

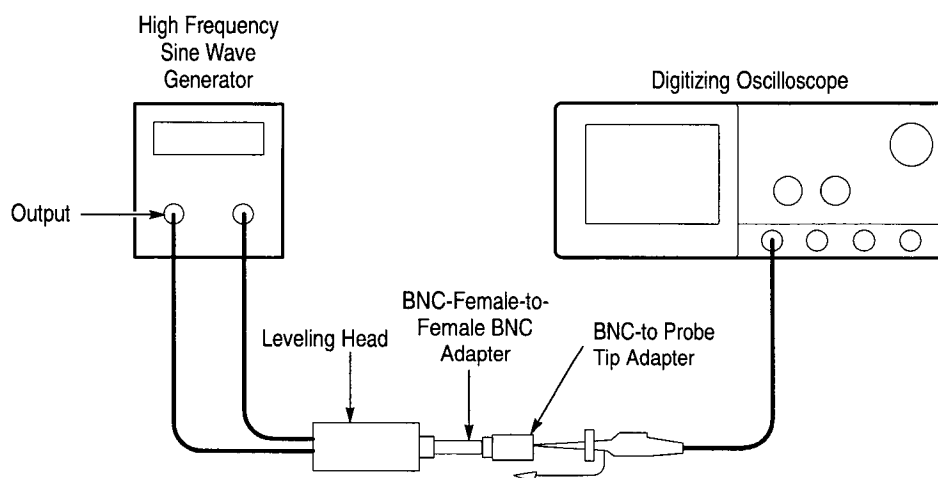

Figure 5-6: Initial Test Hookup

- c. *Initialize the oscilloscope:*
 - Press save/recall **SETUP**.
 - Press the main-menu button **Recall Factory Setup**.
 - Press the side-menu button **OK Confirm Factory Init**.
- d. *Modify the initialized front-panel control settings:*
 - Set the vertical **SCALE** to 500 mV.
 - Set the horizontal **SCALE** to 100 ns.
 - Push **SET LEVEL TO 50%** as required to trigger the signal.
 - Press **SHIFT**. Then press **ACQUIRE MENU**.
 - Press the main-menu button **Mode**. Then press the side-menu button **Average 16**.
 - Press **MEASURE**.
 - Press the main-menu button **Hi-Low Setup**. Then press the side-menu button **Min-Max**.
 - Press the main-menu button **Select Measrmt for Ch1**.
 - Repeatedly press the side-menu button **–more–** until **Pk-Pk** appears in the side menu. Press the side-menu button **Pk-Pk**.
 - Press **CLEAR MENU**.
2. *Confirm that the Probe Compensator signal is within limits for bandwidth:*
 - a. *Display and measure the test signal:*
 - Monitor the **CH 1 Pk-Pk** readout while you set the output of the generator for a 3.0 V (6 division), 6 MHz reference signal.
 - Set the horizontal **SCALE** to 1 ns and set the frequency of the generator to 500 MHz.
 - Read the measurement results at the CH 1 Pk-Pk readout on screen.
 - b. *Check against limits:* CHECK that the **CH 1 Pk-Pk** readout is greater than or equal to 2.1 V.
3. *Disconnect the hookup:*
 - a. Unplug the probe from BNC-to-probe tip adapter.

- b. If substep 2b was passed, the probe adjustment is finished. Reverse the instructions in Figure 5-5, page 5-13, to reinstall the retractable hook probe tip.
- c. If substep 2b was *not* passed, leave the probe tip exposed. Remove the probe from CH 1 and go on to the next procedure *Adjust the Probe — High Frequency Response*.

Adjust the Probe — High Frequency Response

Do not perform this procedure until you have first completed the procedures *Compensate the Probe* and *Measure Probe Bandwidth* on pages 5-10 and 5-12, respectively.

Do not perform this procedure if you have successfully completed *Measure Probe Bandwidth*. Probe adjustment is complete.

Equipment Required	One calibration generator (Item 11) One 50 Ω precision cable (Item 9) One tunnel diode pulser (Item 29) One BNC female-to-female adapter (Item 1) One BNC to probe adapter (Item 2) One 10X attenuator (Item 5) One P6139A 10X probe (Item 17)
---------------------------	---

1. *Install the test hookup and preset the oscilloscope controls:*
 - a. *Access Inner Probe Tip and Adjustment Ports:*
 - The probe tip should be exposed from the procedure *Measure Probe Bandwidth*. If not, follow the instructions in Figure 5-5 to expose the probe tip.
 - Follow the instructions in Figure 5-7 to remove the probe body covers.

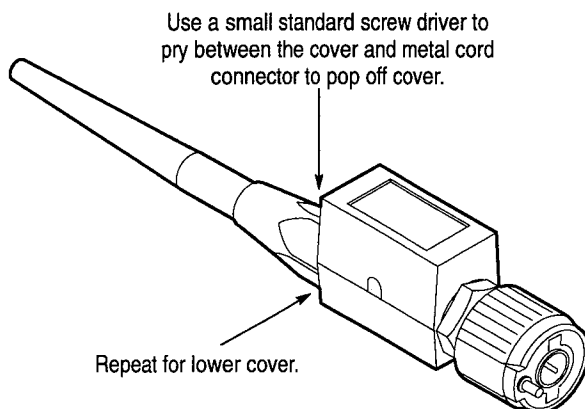

Figure 5-7: Exposing the Probe Body

b. Hook up test-signal source:

- Connect the high-amplitude output of a calibration generator, through a 50 Ω precision cable to the input of a tunnel diode pulser. See Figure 5-8.
- Connect the output of the tunnel diode pulser through a 10X attenuator to CH 1.
- Set the triggering level of the tunnel diode pulser to minimum.

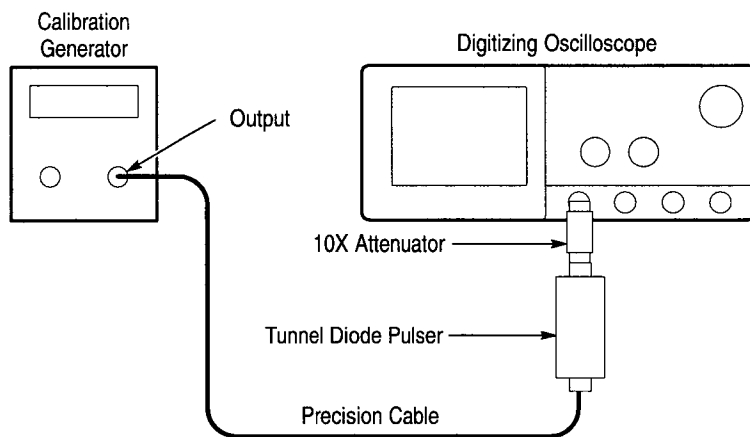

Figure 5-8: Initial Test Hookup

c. Initialize the oscilloscope:

- Press save/recall **SETUP**.

- Press the main-menu button **Recall Factory Setup**.
 - Press the side-menu button **OK Confirm Factory Init**.
- d. *Modify the initialized front-panel control settings:*
- Set vertical **SCALE** to 5 mV.
 - Push **SET LEVEL TO 50%** as required to trigger the signal.
 - Press **VERTICAL MENU**. Then press the main-menu button **Coupling**. Press the side-menu button Ω to toggle to 50 Ω coupling.
 - Press **CLEAR MENU**.
2. *Adjust the Probe:*
- a. *Display and store the reference signal:*
- Set the high-amplitude output of the generator to ≥ 60 V at the input to the tunnel diode pulser.
 - Set the **Period** (repetition rate) to 10 kHz.
 - Advance the triggering level of the tunnel diode pulser until a five to six division square wave appears on screen. Do not advance the knob any further than required to achieve stable amplitude.
 - Use the vertical **POSITION** to center the displayed waveform on screen.
 - Press **SHIFT**; then press **ACQUIRE MENU**.
 - Press the main-menu button **Mode**. Then press the side-menu button **Average 16**.
 - Push **SET LEVEL TO 50%** as required to trigger the signal.
 - Advance the horizontal **SCALE** to 5 ns.
 - Press **HORIZONTAL MENU**.
 - Press the main-menu button **Trigger Position**; press the side-menu button **Set to 20%**.
 - Press **SAVE WAVEFORM**.
 - Press the main-menu button **Save Waveform**. Then press the side-menu button **To Ref 1**.
 - Press **MORE**. Then push the main-menu button **Ref 1**.

b. *Display the test signal:*

- Disconnect the tunnel diode pulser at CH 1 and remove the 10X attenuator.
- Connect the output of the tunnel diode pulser through a BNC-female-to-BNC-female adapter to a BNC-to-probe tip adapter.
- Install the probe on CH 1.
- Plug the probe tip from the probe into the BNC-to-probe tip adapter.
- Press **VERTI+CAL MENU**; then press **CH 1**.
- Press the main-menu button **Coupling**. Then press the side-menu button **Ω** to toggle to 1 MΩ coupling.
- Push **SET LEVEL TO 50%** as required to trigger the signal.
- Adjust the triggering level of the tunnel diode pulser until a five to six division square wave appears on screen. Do not advance the knob any further than required to achieve stable amplitude.

c. *Make the adjustments:*

- Locate the various adjustments in Figure 5–9.
- Manually adjust the front-corner response of the probe to best match the response of the Ref 1 waveform. It is more important to match the response during the first 5 ns than during the entire first 20 ns the adjustments affect.

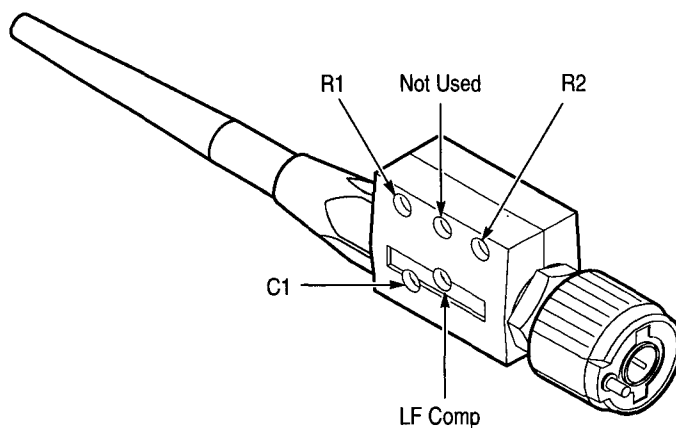

Figure 5–9: Locations of P6139A Probe Adjustments

- See Figure 5–10 to see what areas on the front corner that the various adjustments affect.
- d. Recheck Probe Bandwidth:**
- Redo the procedure *Adjust Probe — High Frequency Response* to check if probe now meets its bandwidth requirement.
 - If the bandwidth requirement is met, adjustment is complete. Skip to step 3.
 - If the bandwidth requirement is *not* met, redo this procedure, increasing front corner overshoot slightly relative to the stored waveform.
 - Repeat this step (d) until the bandwidth requirement is met.

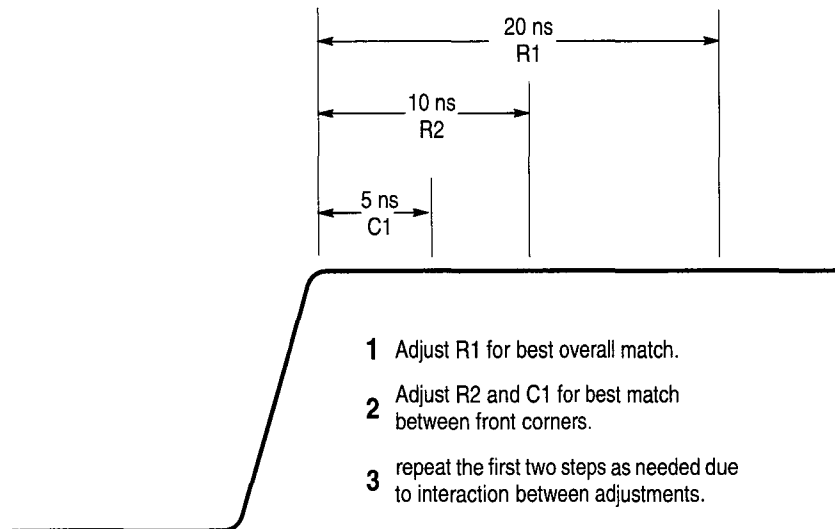

Figure 5–10: Adjustments versus Front-Corner Response

3. *Disconnect the hookup:* Unplug the probe from the BNC-to-probe tip adapter. Reverse the instructions in Figure 5–5, page 5–13, to reinstall the retractable probe tip.

Display Assembly Adjustment

STOP. It is not necessary to do this procedure to perform a complete adjustment. Only use this procedure to adjust the display assembly if it has been repaired or if brightness and contrast have become unsatisfactory.

Rotation, Brightness, and Contrast Adjustment

Equipment Required	One 6X magnifier (Item 15)
	One J16 Photometer with a J6503 Luminance Probe (Item 16)

1. Access the inside of the oscilloscope: See *Removal and Installation Procedures* in Section 6 to remove the cabinet.
2. Adjust the display rotation:
 - a. Display the Composite test pattern:
 - Leave the oscilloscope powered off.
 - Set the DIP switch, located near the front of the A11 DRAM Processor/Display, as follows:

Switch No.	1	2	3	4	5	6	7	8
Open			X			X	X	
Closed	X	X		X	X			X

- Power on the oscilloscope.
 - Press **SHIFT**; then press **UTILITY**.
 - Repeatedly press the main-menu button **System** until **Diag/Err** is highlighted in the pop-up menu.
 - Repeatedly press the main-menu button **Area** until **Display** is highlighted in the pop-up menu.
 - Repeatedly press the side-menu button **–more–** until **Composite** appears in the side menu. Push **Composite**.
 - Press the main-menu button **EXECUTE**; then press the side-menu button **Ok Confirm Run Test**.
- b. Adjust R401 (TRACE ROTATION) to minimize the display's tilt. Use the frame around the display as a reference. R401 is the second adjustment from the fan.

3. Adjust the display brightness

- Locate R403 (BRIGHTNESS). It is one of the adjustments on the left side of the instrument located just ahead of the fan. It is the fourth adjustment from the fan.
- Observe the luminance patches using a 6X magnifier.
- Adjust R403 (BRIGHTNESS) until the background raster lines in the 5% luminance patch (see Figure 5-11) just disappear, while the lines in the 10% luminance patch are just visible, when both are viewed through the magnifier.

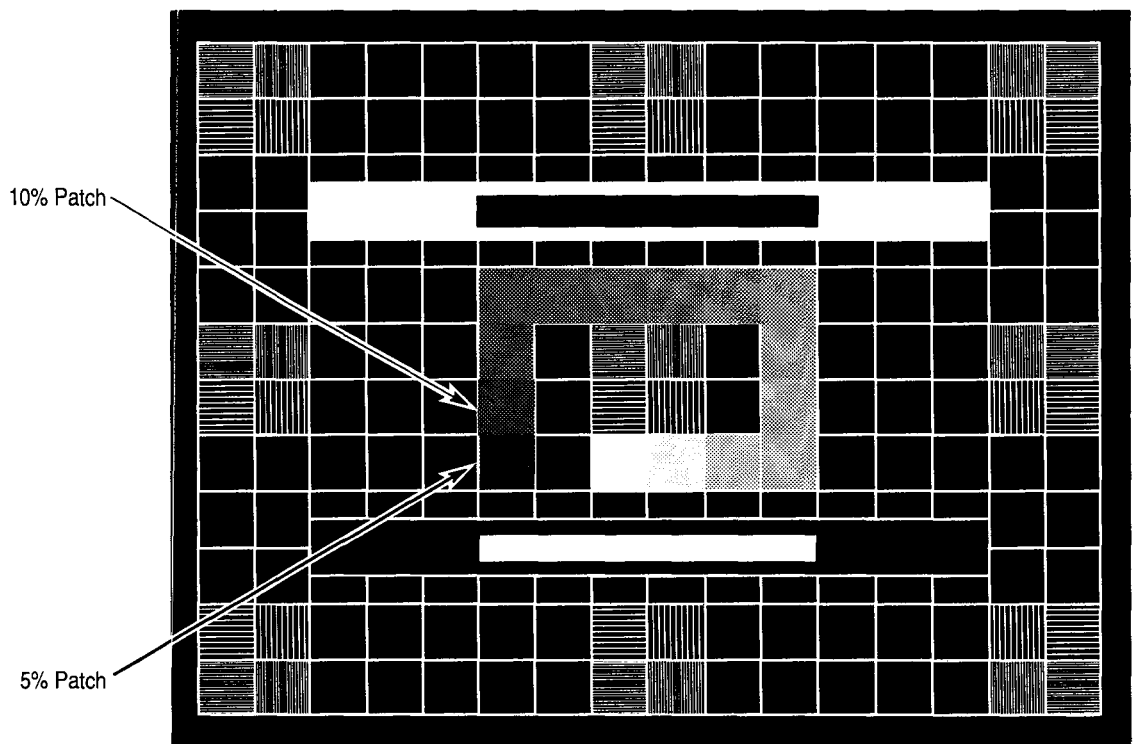

Figure 5-11: Five and Ten Percent Luminance Patches

4. Adjust the display contrast:

a. Display the White Field test pattern:

- Press the center main-menu button to display the main-menu.
- Press the main-menu button **Tests**.
- Repeatedly press the side-menu button **-more-** until **White Field** appears in the side menu. Push **White Field**.

Adjustment Procedures

- Press the main-menu button **EXECUTE**; then press the side-menu button **Ok Confirm Run Test**.
- b. *Make the contrast adjustment:*
- Locate R404. It is one of the adjustments on the left side of the instrument located just ahead of the fan. It is the fifth adjustment from the fan.
 - Monitor the luminance at center screen using a J16 photometer and a luminance probe.
 - Adjust R404 (CONTRAST) for a reading of 40 foot lamberts.

NOTE. *The adjustments for contrast and brightness interact with each other.*

5. *Restore the oscilloscope to normal operation:*

- a. Restore the dip switch to the settings that follow:

Switch No.	1	2	3	4	5	6	7	8
Open			X					
Closed	X	X		X	X	X	X	X

- b. Power off the oscilloscope.
- c. See *Removal and Installation Procedures* in Section 6 to reinstall the cabinet and other modules removed in step 1.

Maintenance

This section contains the information needed to do periodic and corrective maintenance on the TDS 684A and 744 Digitizing Oscilloscopes. The following subsections are included:

- *Preparation* — Introduction plus general information on preventing damage to internal modules when doing maintenance.
- *Inspection and Cleaning* — Information and procedures for inspecting the oscilloscope and cleaning its external and internal modules.
- *Removal/Replacement Instructions* — Procedures for the removal of defective modules and replacement of new or repaired modules. Also included is a procedure for disassembly of the oscilloscope for cleaning.
- *Troubleshooting* — Information for isolating and troubleshooting failed modules. Included are instructions for operating the oscilloscope's internal diagnostic routines and troubleshooting trees. Most of the trees make use of these internal diagnostic routines to speed fault isolation to a module.

Related Maintenance Procedures

The following sections contain information/procedures related to maintenance.

- Section 2, *Operating Information*, covers instructions useful when operating the oscilloscope in order to troubleshoot it. It also details the service strategy and lists options for obtaining maintenance service and for replacing failed modules.
- Section 3, *Theory of Operation*, contains a circuit description at the module, or block, level.
- Section 4, *Performance Verification*, contains procedures that may be useful in isolating problems to modules by testing oscilloscope performance.
- Section 5, *Adjustment Procedures*, addresses after repair adjustment and the interval between periodic adjustments. It contains a procedure for adjusting the internal circuits of the oscilloscope.
- Section 8, *Replaceable Electrical Parts*, lists all replaceable electrical parts by part number.
- Section 9, *Diagrams*, contains a block diagram using individual modules as blocks and an interconnection diagram showing connections between the modules.

- Section 10, *Mechanical Parts List*, lists all field replaceable modules by part number.

Preparation

Preventing ESD



CAUTION. *Static discharge can damage any semiconductor component in this oscilloscope.*

Precautions. When performing any service which requires internal access to the oscilloscope, adhere to the following precautions to avoid damaging internal modules and their components due to electrostatic discharge (ESD).

1. Minimize handling of static-sensitive modules.
2. Transport and store static-sensitive modules in their static protected containers or on a metal rail. Label any package that contains static-sensitive modules.
3. Discharge the static voltage from your body by wearing a grounded antistatic wrist strap while handling these modules. Do service of static-sensitive modules only at a static-free work station.
4. Nothing capable of generating or holding a static charge should be allowed on the work station surface.
5. Handle circuit boards by the edges when possible.
6. Do not slide the modules over any surface.
7. Avoid handling modules in areas that have a floor or work-surface covering capable of generating a static charge.

Susceptibility to ESD. Table 6–1 lists the relative susceptibility of various classes of semiconductors. Static voltages of 1 kV to 30 kV are common in unprotected environments.

Table 6–1: Relative Susceptibility to Static-Discharge Damage

Semiconductor Classes	Relative Susceptibility Levels¹
MOS or CMOS microcircuits or discrete circuits, or linear microcircuits with MOS inputs (most sensitive)	1
ECL	2
Schottky signal diodes	3
Schottky TTL	4
High-frequency bipolar transistors	5
JFET	6
Linear microcircuits	7
Low-power Schottky TTL	8
TTL (least sensitive)	9

¹ **Voltage equivalent for levels (voltage discharged from a 100 pF capacitor through resistance of 100 ohms):**

1 = 100 to 500 V

2 = 200 to 500 V

3 = 250 V

4 = 500 V

5 = 400 to 600 V

6 = 600 to 800 V

7 = 400 to 1000 V (est.)

8 = 900 V

9 = 1200 V

Inspection and Cleaning

Inspection and Cleaning describes how to inspect for dirt and damage on, and how to clean the exterior and interior of the TDS 684A and 744 Digitizing Oscilloscopes. Inspection and cleaning are done as preventive maintenance. Preventive maintenance, when done regularly, may prevent oscilloscope malfunction and enhance its reliability.

Preventive maintenance consists of visually inspecting and cleaning the oscilloscope and using general care when operating it.

How often to do maintenance depends on the severity of the environment in which the oscilloscope is used. A proper time to perform preventive maintenance is just before oscilloscope adjustment.

General Care

The cabinet helps keep dust out of the oscilloscope and should normally be in place when operating the oscilloscope. The oscilloscope's front cover protects the front panel and display from dust and damage. Install it when storing or transporting the oscilloscope.

Inspection and Cleaning Procedures

Inspect and clean the oscilloscope as often as operating conditions require. The collection of dirt on components inside can cause them to overheat and break-down. (Dirt acts as an insulating blanket, preventing efficient heat dissipation.) Dirt also provides an electrical conduction path that could cause an oscilloscope failure, especially under high-humidity conditions.



CAUTION. *Avoid the use of chemical cleaning agents which might damage the plastics used in this oscilloscope. Use only deionized water when cleaning the menu buttons or front-panel buttons. Use a 75% isopropyl alcohol solution as a cleaner and rinse with deionized water. Before using any other type of cleaner, consult your Tektronix Service Center or representative.*

Inspection — Exterior. Inspect the outside of the oscilloscope for damage, wear, and missing parts, using Table 6-2 as a guide. Oscilloscopes that appear to have been dropped or otherwise abused should be checked thoroughly to verify correct operation and performance. Immediately repair defects that could cause personal injury or lead to further damage to the oscilloscope.

Table 6–2: External Inspection Check List

Item	Inspect For	Repair Action
Cabinet, front panel, and cover	Cracks, scratches, deformations, damaged hardware or gaskets.	Repair or replace Replace defective module.
Front-panel knobs	Missing, damaged, or loose knobs.	Repair or replace missing or defective knobs.
Connectors	Broken shells, cracked insulation, and deformed contacts. Dirt in connectors.	Repair or replace Replace defective modules. Clear or wash out dirt.
Carrying handle, bail, cabinet feet.	Correct operation.	Repair or replace Replace defective module.
Accessories	Missing items or parts of items, bent pins, broken or frayed cables, and damaged connectors.	Repair or replace Replace damaged or missing items, frayed cables, and defective modules.

Cleaning Procedure — Exterior.

To clean the oscilloscope exterior, do the following:

1. Remove loose dust on the outside of the oscilloscope with a lint free cloth.
2. Remove remaining dirt with a lint free cloth dampened in a general purpose detergent-and-water solution. Do not use abrasive cleaners.
3. Clean the light filter protecting the monitor screen with a lint-free cloth dampened with either isopropyl alcohol or, preferably, a gentle, general purpose detergent-and-water solution.



CAUTION. To prevent getting moisture inside the oscilloscope during external cleaning, use only enough liquid to dampen the cloth or applicator.

Inspection — Interior. To access the inside of the oscilloscope for inspection and cleaning, refer to the *Removal and Installation Procedures* in this section.

Inspect the internal portions of the oscilloscope for damage and wear, using Table 6–3 as a guide. Defects found should be repaired immediately.

If any electrical module is repaired or replaced, check Table 5–2 in Section 5 to see if it is necessary to adjust the oscilloscope.



CAUTION. To prevent damage from electrical arcing, ensure that circuit boards and components are dry before applying power to the oscilloscope.

Table 6-3: Internal Inspection Check List

Item	Inspect For	Repair Action
Circuit boards	Loose, broken, or corroded solder connections. Burned circuit boards. Burned, broken, or cracked circuit-run plating.	Repair or replace the module. Remove failed module and replace with a fresh module.
Resistors	Burned, cracked, broken, blistered condition.	Repair or replace the module. Replace failed module and replace with a fresh module.
Solder connections	Cold solder or rosin joints.	Resolder joint and clean with isopropyl alcohol.
Capacitors	Damaged or leaking cases. Corroded solder on leads or terminals.	Repair or replace the module. Remove damaged module and replace with a fresh module from the factory.
Semiconductors	Loosely inserted in sockets. Distorted pins.	Firmly seat loose semiconductors. Remove devices that have distorted pins. Carefully straighten pins (as required to fit the socket), using long-nose pliers, and reinsert firmly. Ensure that straightening action does not crack pins, causing them to break off.
Wiring and cables	Loose plugs or connectors. Burned, broken, or frayed wiring.	Firmly seat connectors. Repair or replace modules with defective wires or cables.
Chassis	Dents, deformations, and damaged hardware.	Straighten, repair, or replace defective hardware.

Cleaning Procedure — Interior.

To clean the oscilloscope interior, do the following:

1. Blow off dust with dry, low-pressure, deionized air (approximately 9 psi).
2. Remove any remaining dust with a lint free cloth dampened in isopropyl alcohol (75% solution) and rinse with warm deionized water. (A cotton-tipped applicator is useful for cleaning in narrow spaces and on circuit boards.)

STOP. If, after doing steps 1 and 2, a module is clean upon inspection, skip the remaining steps.

3. If steps 1 and 2 do not remove all the dust or dirt, the oscilloscope may be spray washed using a solution of 75% isopropyl alcohol by doing steps 4 through 8.
4. Gain access to the parts to be cleaned by removing easily accessible shields and panels (see *Removal and Installation Procedures*).
5. Spray wash dirty parts with the isopropyl alcohol and wait 60 seconds for the majority of the alcohol to evaporate.
6. Use hot (120° F to 140° F) deionized water to thoroughly rinse them.
7. Dry all parts with low-pressure, deionized air.
8. Dry all components and assemblies in an oven or drying compartment using low-temperature (125° F to 150° F) circulating air.

Lubrication. There is no periodic lubrication required for this oscilloscope.

Maintenance

Removal and Installation Procedures

This subsection contains procedures for removal and installation of all mechanical and electrical modules. Any electrical or mechanical module, assembly, or part listed in Section 10 of this manual is a module.

Preparation — Please Read



WARNING. *Before doing this or any other procedure in this manual, read the Safety Summary found at the beginning of this manual. Also, to prevent possible injury to service personnel or damage to this oscilloscope's components, read Installation in Section 2, and Preventing ESD in this section.*

This subsection contains the following items:

- This preparatory information that you need to properly do the procedures that follow.
- List of tools required to remove and disassemble all modules.
- Three module locator diagrams for finding the External Modules (see Figure 6-1), Outer-Chassis Modules (see Figure 6-2), and Inner-Chassis Modules (see Figure 6-3) in this oscilloscope.
- Procedures for removal and reinstallation of the electrical and mechanical modules.
- A disassembly procedure for removal of all the major modules from the oscilloscope at one time and for reassembly of those modules into the oscilloscope. Such a complete disassembly is normally only done when completely cleaning the oscilloscope. (Instructions for doing the actual cleaning are found under *Inspection and Cleaning* at the beginning of this section.)
- Module disassembly procedures.



WARNING. *Before doing any procedure in this subsection, disconnect the power cord from the line voltage source. Failure to do so could cause serious injury or death.*

List of Modules Section 10 lists all modules.

General Instructions

STOP READ THESE GENERAL INSTRUCTIONS BEFORE REMOVING A MODULE.

First read over the Summary of Procedures that follows to understand how the procedures are grouped. Then read Equipment Required for a list of the tools needed to remove and install modules in this oscilloscope.

If you are disassembling this oscilloscope for cleaning, go to the procedure Disassembly for Cleaning on page 6–53.

If you are removing a module for service, begin by doing the procedure Access Procedure (page 6–15). By following the instructions in that procedure, you remove the module to be serviced while removing the minimum number of additional modules.

Summary of Procedures

The procedures are described in the order in which they appear in this section. In addition, you can look up any procedure for removal and reinstallation of any module in the *Table of Contents* of this manual.

- The *Access Procedure* on page 6–15 first directs you to any procedure(s) (if any) that are required to access the module to be serviced, then it directs you to the procedure to remove that module.
- *Procedures for External Modules* on page 6–16 are procedures for removing modules the removal of which do not require internal access to the oscilloscope.
- *Procedures for Outer-Chassis Modules* on page 6–29 are procedures for removing modules the removal of which require access internal to the instrument but external to the chassis.
- *Procedures for Inner-Chassis Modules* on page 6–46 are procedures for removing modules the removal of which require access internal to the instrument and internal to the chassis.
- *Disassembly for Cleaning* on page 6–53 is a procedure, based on the removal procedures just described, that removes all modules for cleaning. Instructions for cleaning are found in *Inspection and Cleaning*, which begins this section.

NOTE. *Read the cleaning procedure before disassembling the oscilloscope for cleaning.*

Equipment Required. Most modules in this oscilloscope can be removed with a screwdriver handle mounted with a size T-15, Torx® screwdriver tip. *Use this*

tool whenever a procedure step instructs you to remove or install a screw unless a different size screwdriver is specified in that step. All equipment required to remove and reinstall each module is listed in the first step of its procedure.

Table 6-4: Tools Required for Module Removal

Item No.	Name	Description	Tektronix Part Number
1	Screwdriver handle	Accepts Torx®-driver bits	003-0301-00
2	T-15 Torx tip	Torx®-driver bit for T-15 size screw heads	003-0966-00
3	T-20 Torx tip	Torx®-driver bit for T-20 size screw heads	003-0866-00
4	T-20 Torx tip	Special Tool: Narrow Torx®-driver bit for T-20 size screw heads (Fan removal only)	003-1457-01
5	Flat-bladed screwdriver	Screwdriver for removing standard-headed screws	
6	Needle-Nose Pliers	Standard tool	
7	Nutdriver, ¼ inch	Standard tool	
8	Retaining Ring Pliers	Standard tool; 1½ inch minimum throw	
9	Angle-Tip Tweezers	Standard tool	
10	Soldering Iron	Standard tool	
11	Pliers	Standard tool	
12	Solder Wick	Standard tool	
13	⅝ hex tip	Bit for ⅝ hex set screw	
14	Adhesive	TRA-CON: Tra-Bond #BA-2114	

Removal and Installation Procedures

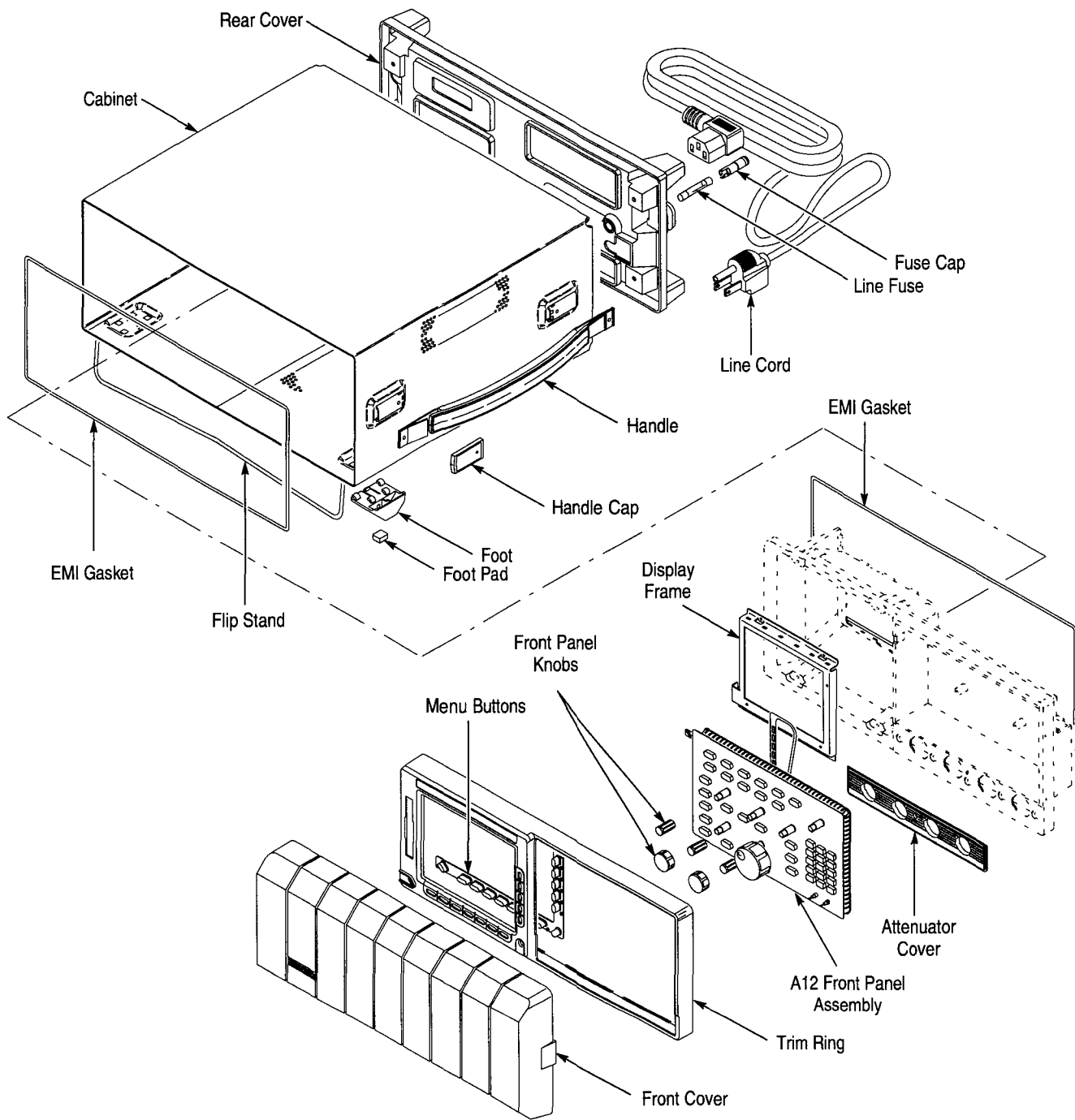

Figure 6-1: External Modules

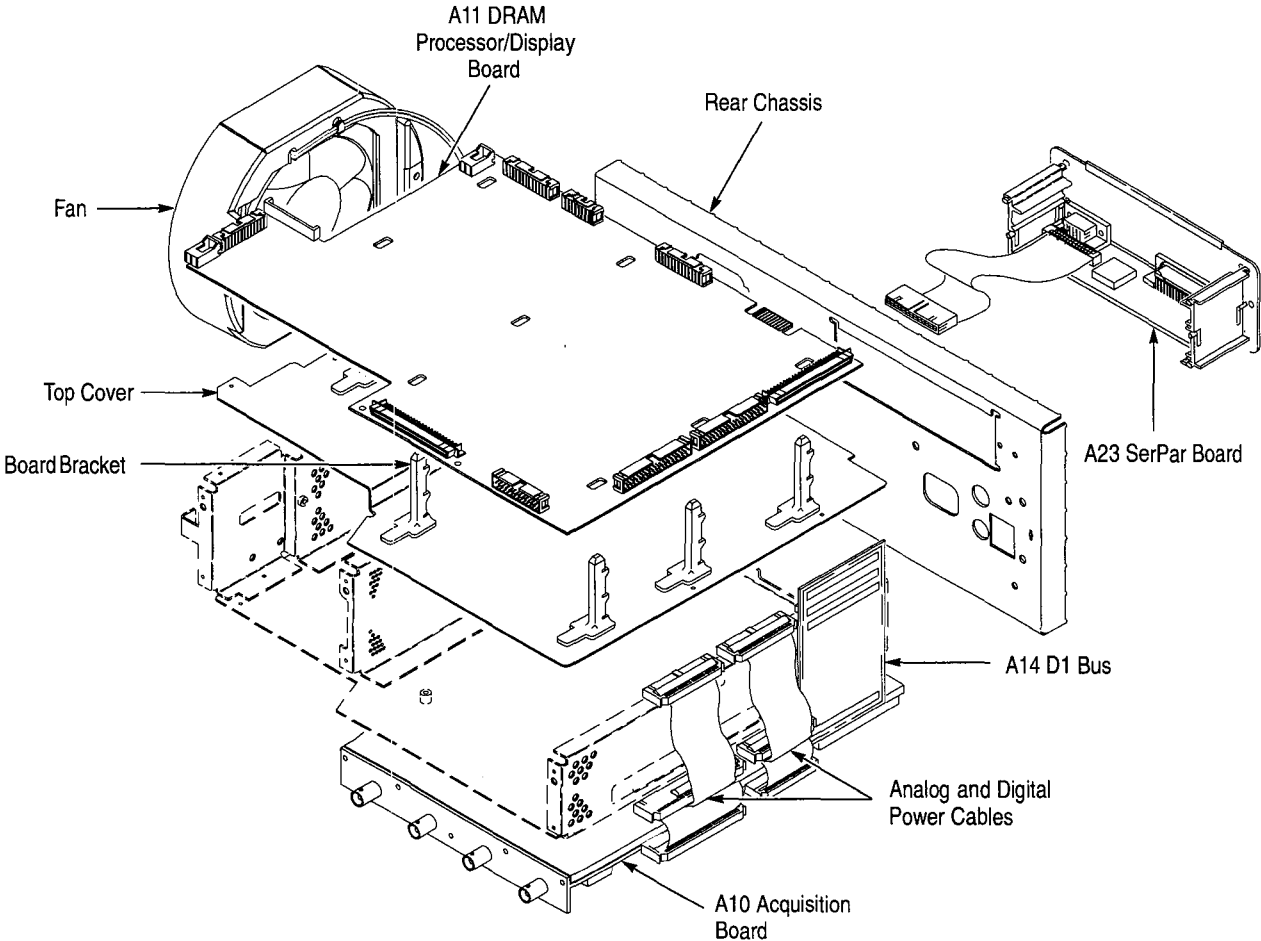

Figure 6-2: Outer-Chassis Modules

Removal and Installation Procedures

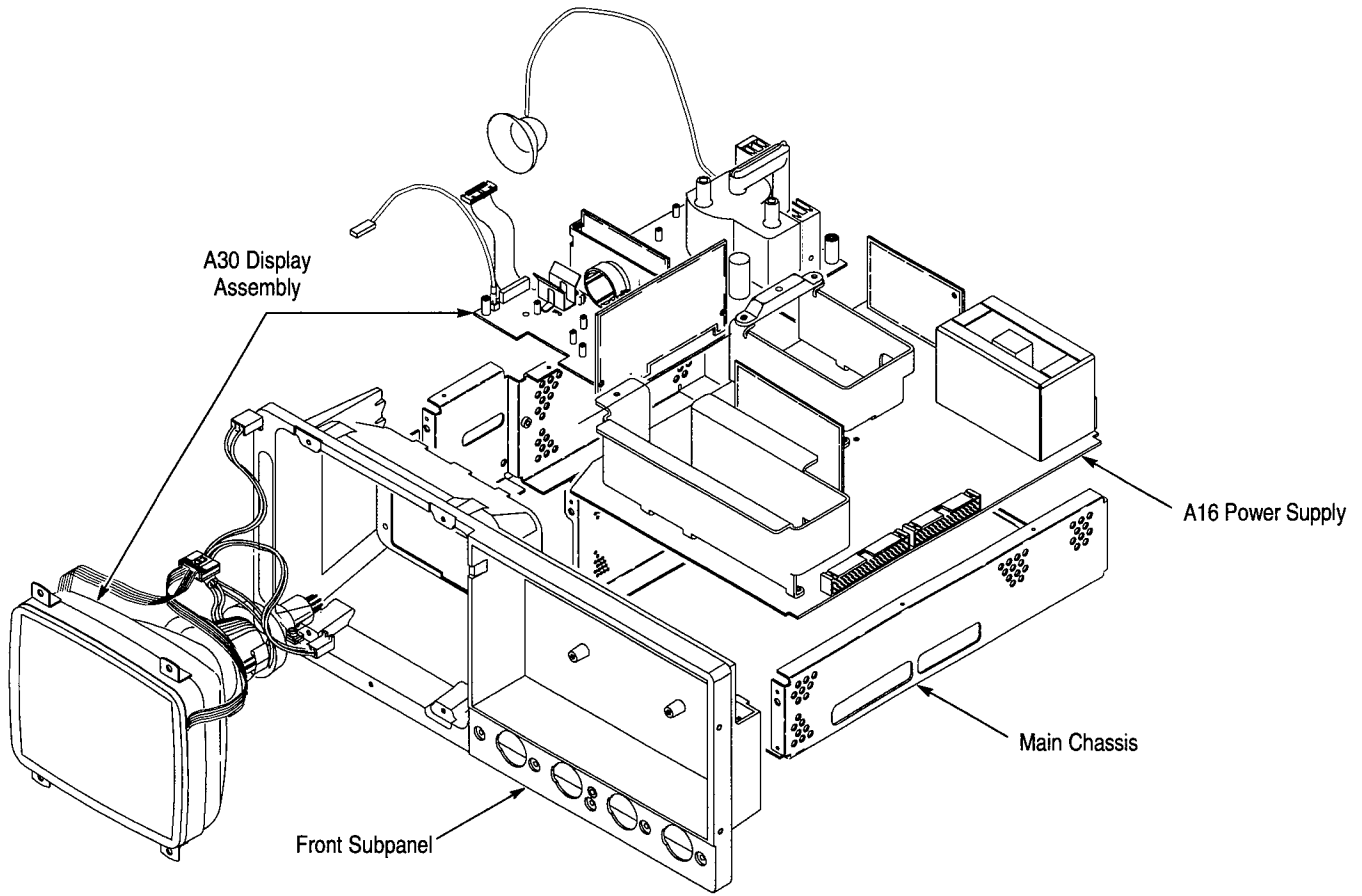

Figure 6-3: Inner-Chassis Modules

Access Procedure

Begin with this procedure when you have identified a module to be removed for service and have read *General Instructions* found earlier in this section.

1. *Locate module to be removed:*
 - a. Find the module to be removed in the module locator diagrams, Figures 6-1 through 6-3.
 - b. Once the module is found, note from the title of the figure whether the module is an external, outer-chassis mounted, or inner-chassis mounted part.
2. *If the module is externally mounted, no internal access is required; remove the module:* Find and do the procedure whose title matches the name of the module to be removed under *Procedures for External Modules* (page 6-16).
3. *If the module is an outer- or inner-chassis module, access the inside of the instrument:*
 - a. First do the procedure *Line Fuse and Line Cord*; then do the procedure *Rear Cover and Cabinet*. Both are found under *Procedures for External Modules* immediately following this procedure.
 - b. After completing those procedures, return to this procedure and continue with step 4.
4. *If the module is an outer-chassis module, remove it:*
 - a. If removing the attenuator or display-frame assembly, first do the procedure *Front Cover, Trim Ring, Menu Buttons, and Attenuator Panel*, found under *Procedures for External Modules* (page 6-16).
 - b. Find and do the procedure whose title matches the name of the module to be removed under *Procedures for Outer-Chassis Modules*, on page 6-29.
5. *If the module is an inner-chassis module, access the inner-chassis:*
 - a. If removing the display tube, display-driver board, or the front subpanel, first do the procedure *Front Cover, Trim Ring, Menu Buttons, and Attenuator Panel*, found under *Procedures for External Modules*. Also remove the display-frame assembly found under *Procedures for External Modules*, on page 6-16.
 - b. Also, if removing the front subpanel, do *A12 Front-Panel Assembly* also found under *Procedures for External Modules*.

- c. Do, in the order listed, the three procedures *A14 D1 Bus and Analog-Power and Digital-Power Cables*, *A11 Processor/Display Board* and *Top Cover* found under *Procedures for Outer-Chassis Modules*, page 6–29.
 - d. Find and do the procedure whose title matches the name of the module to be removed under *Procedures for Inner-Chassis Modules*, page 6–46.
6. *Reinstall all modules removed:* Read the instructions found at the end of the procedure that removes the module to be serviced — they will guide you in reinstalling all modules removed.

Procedures for External Modules

Do the *Access Procedure* (page 6–15) before doing any procedure in this collection.

The following procedures are found here and are listed in order presented.

- *Front-Panel Knobs*
- *Line Fuse and Line Cord*
- *EMI Gaskets*
- *Rear Cover and Cabinet*
- *Front Cover, Trim Ring, Menu Buttons, and Attenuator Panel*
- *A12 Front-Panel Assembly*
- *Display Frame Assembly*
- *Cabinet Modules*

Front-Panel Knobs

1. *Assemble equipment and locate modules to be removed:* Have an angled-tip tweezers (Item 9) handy. Find the knob(s) to be removed on the front panel.
2. *Orient the oscilloscope:* Set the oscilloscope so its bottom is down on the work surface and its front is facing you.
3. *Remove the knob(s):* Grasp any knob you wish to remove and pull it straight out from the front panel slightly to create some clearance between the base of the knob and the front panel. Insert the tweezers between the knob and front panel and use them to remove the knob. See Figure 6–4.
4. *Reinstallation:* To reinstall, align knob to shaft and push it in until it snaps.

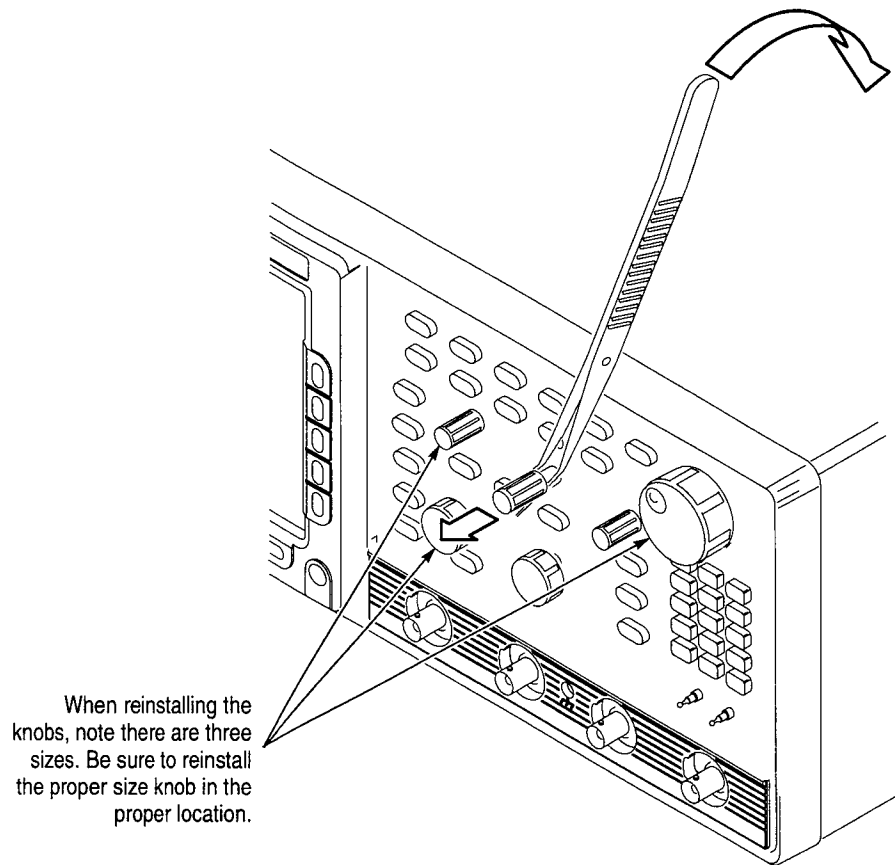

Figure 6-4: Knob Removal

Line Fuse and Line Cord

1. *Assemble equipment and locate modules to be removed:* Have a flat-bladed screwdriver (Item 5) handy. Locate the line fuse and line cord in the locator diagram *External Modules*, Figure 6-1.
2. *Orient the oscilloscope:* Set the oscilloscope so its bottom is down on the work surface and its rear is facing you. If you are servicing the line fuse, do the next step; if you are servicing the line cord, skip to step 4.
3. *Remove line fuse:* Find the fuse cap on the rear panel. (See Figure 6-5.) Now, remove the fuse cap by turning it counter clockwise using a flat-bladed screwdriver, and remove the line fuse. Reverse procedure to reinstall.
4. *Remove line cord:* Find the line cord on the rear cover. (See Figure 6-5.) Now, remove the line-cord retaining clamp by first unplugging the line cord from its receptacle. Next, grasp both the line cord and the retaining clamp and rotate it 90 degrees counter-clockwise. Pull the line cord and clamp away to complete the removal. Reverse procedure to reinstall.

5. *Reinstallation:* Do in reverse steps 3 and 4 to reinstall the line cord and then the line fuse.

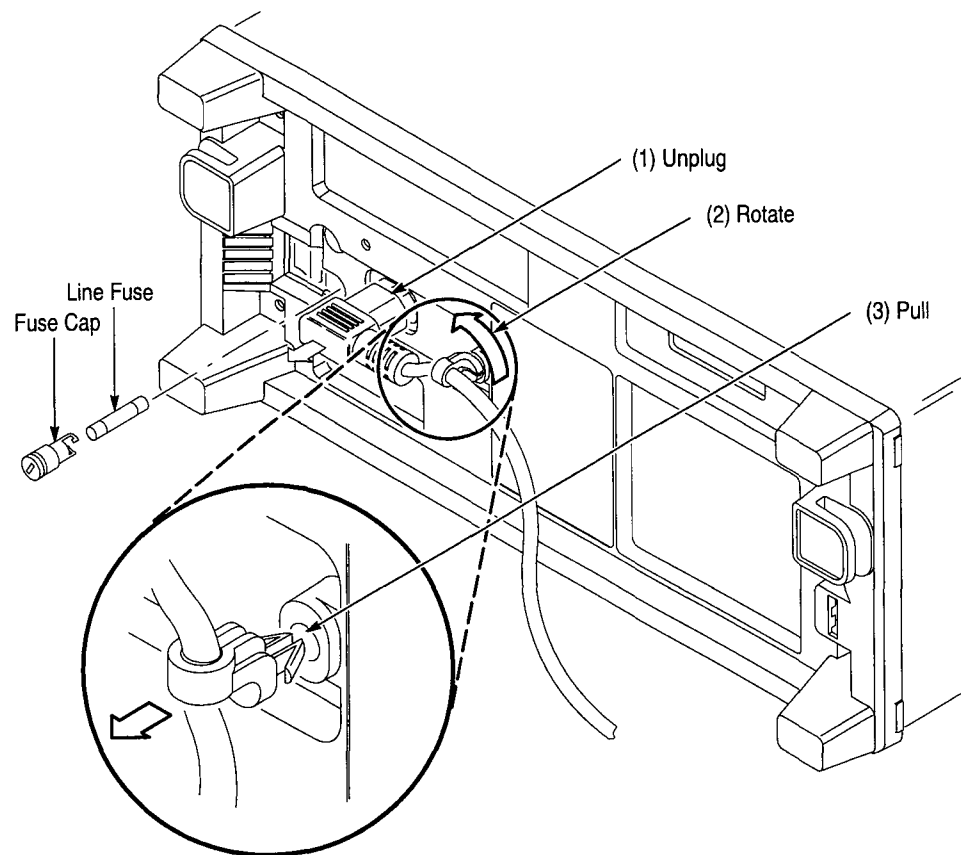

Figure 6-5: Line Fuse and Line Cord Removal

EMI Gaskets

See *Rear Cover and Cabinet* procedure on page 6-18.

Rear Cover and Cabinet

1. *Assemble equipment and locate modules to be removed:*
 - a. Have handy a screwdriver with a size T-20 Torx® tip (Items 1 and 3).
 - b. Make sure the oscilloscope's front cover is installed; if it's not, install it by snapping its edges over the trim ring.
 - c. Locate the rear cover and cabinet in the locator diagram *External Modules*, Figure 6-1.
2. *Orient the oscilloscope:* Set the oscilloscope so its face is down with its front cover on the work surface and its bottom facing you.

3. *Disconnect the line cord:* Unplug the line cord from its receptacle at the rear cover.
4. *Remove rear cover:* Remove the four screws securing the rear cover to the oscilloscope. Lift off the rear cover.
5. *Remove the cabinet:*
 - a. At the rear of the cabinet, grasp its left and right edges.
 - b. Pull upward to slide the cabinet off the oscilloscope. Take care not to bind or snag the cabinet on the oscilloscope's internal cabling as you remove it.

STOP. DO NOT do steps 6 through 8 to remove the EMI gasket(s) unless they must be replaced due to damage. If you are not replacing those gaskets, skip to step 9.

When reinstalling EMI gaskets and/or the oscilloscope cabinet, carefully follow the instructions given. Unless they are performed properly, the oscilloscope may not meet its emissions requirements (EMI).

6. *Assemble equipment and locate modules to be removed:*
 - a. Have handy a pair of needle-nose pliers (Item 6).
 - b. Locate the modules to be removed in the locator diagram *External Modules*, Figure 6-1.
7. *Remove the EMI gaskets:*
 - a. Look for the point where the ends of the gasket touch in the channel at the rear edge of the cabinet.
 - b. Use a pair of needle-nose pliers to pry up one of the ends.
 - c. Grasp the EMI gasket, and gently pull it out of the its channel.
 - d. Repeat substeps a through c to remove the gasket from its channel on the front casting.
8. *Reinstallation of EMI gaskets:* Press each EMI gasket back into its groove at the rear edge of the cabinet or front casting. Make sure the ends of the gasket touch, but do not overlap, when installing. (Cut off excess length if required to prevent overlap.)
9. *Reinstallation of cabinet and rear cover:*
 - a. Do in reverse order steps 3 and 4 to reinstall the cabinet.

Removal and Installation Procedures

- b.** Take care not to bind or snag the cabinet on internal cabling; redress cables as necessary.
- c.** When sliding the cabinet, be sure that the front edge of the cabinet aligns with the groove containing the EMI shield on the front casting.
- d.** Be sure that the ridge around the rear chassis slides into the groove containing a second EMI cable on the rear of the cabinet.
- e.** When reinstalling the four screws at the rear panel, tighten them to 16 foot-lbs torque.
- f.** See the procedure *Line Fuse and Line Cord* to reinstall the line cord, which completes the oscilloscope reassembly.

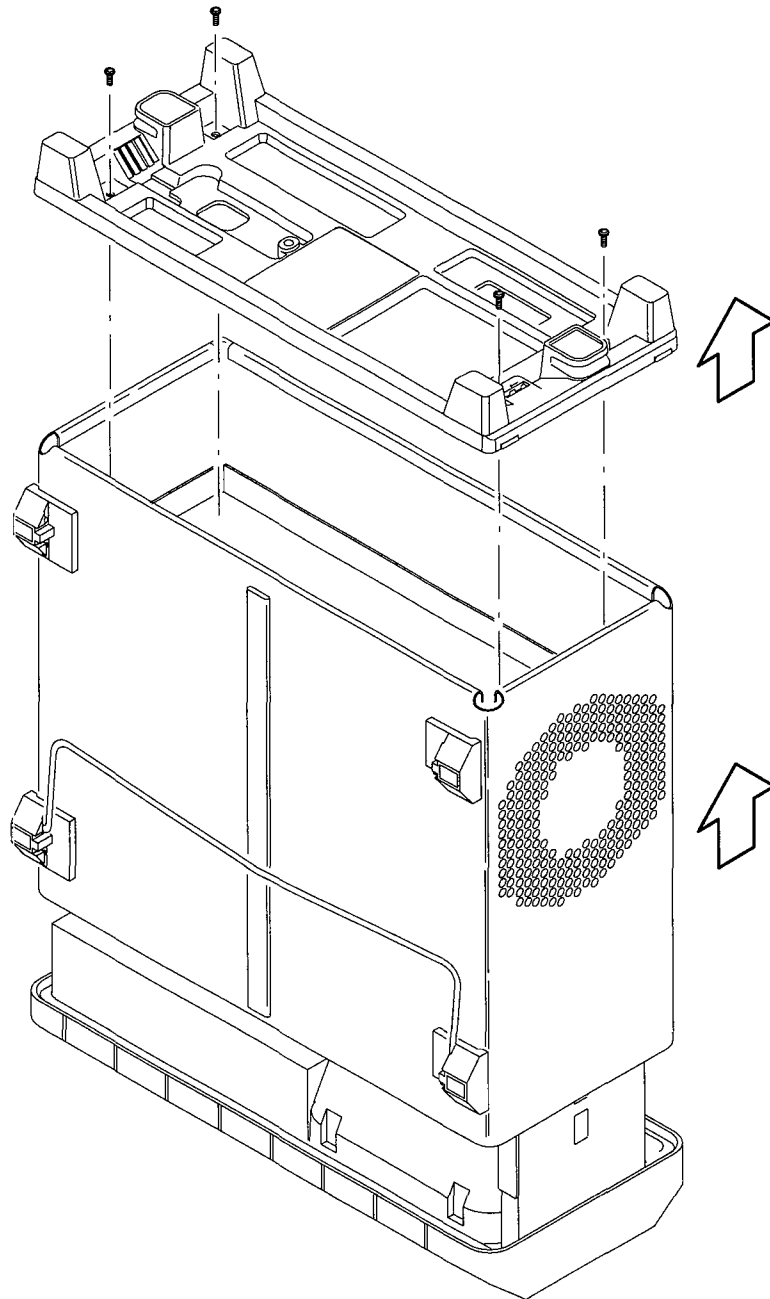

Figure 6-6: Rear Cover and Cabinet Removal

Removal and Installation Procedures

**Front Cover, Trim Ring,
Menu Buttons, and
Attenuator Panel**

1. *Assemble equipment and locate modules to be removed:* No tools are needed. Locate the modules to be removed in the locator diagram *External Modules*, Figure 6-1.
2. *Orient the oscilloscope:* Set the oscilloscope so its rear is down on the work surface and its bottom is facing you.
3. *Remove the front cover:* Grasp the front cover by its left and right edges and snap it off of the front subpanel. When reinstalling, align and snap back on. See Figure 6-7.

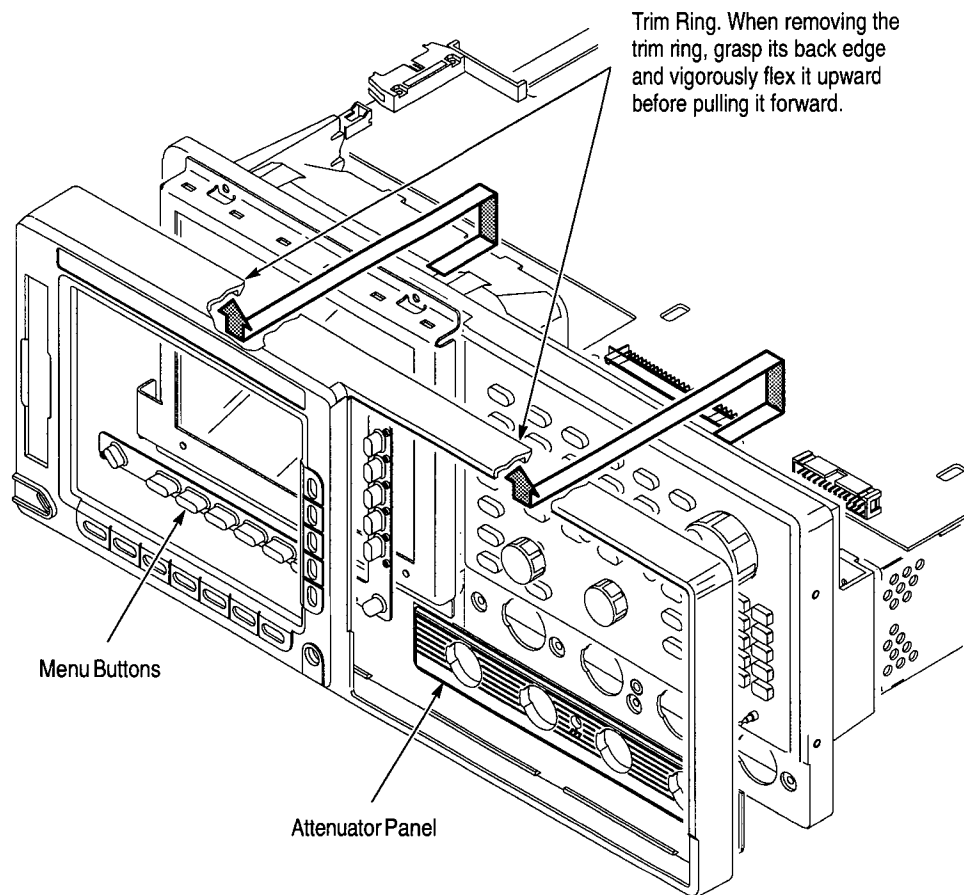

Figure 6-7: Front Cover, Trim Ring, Menu Buttons, and Attenuator Panel Removal (Front Cover not Shown)

STOP. DO NOT touch the carbon contact points on the menu buttons installed in the trim ring. Also, do not touch the contacts on the flex circuit exposed when you remove the trim ring.

4. *Remove the trim ring:* Grasp the trim ring by its top edge and pry it up and lift it forward to snap it off of the front subpanel. If servicing the menu buttons, lift them out of the trim ring. (When reinstalling, reinsert the menu buttons, align the trim ring to the front subpanel and press it back on.)
5. *Remove the attenuator panel:* Gently pry, using your fingers, the snap-off/snap-on attenuator panel away from the front subpanel to remove it. (When reinstalling, use your hands to press it back on.)
6. *Reinstallation:* Do in reverse steps 3–5 to reinstall the attenuator panel, menu buttons, trim ring, and the front cover, following the reinstallation instructions found in each step.

A12 Front-Panel Assembly

NOTE. *This procedure includes removal and reinstallation instructions for the front panel and front panel buttons. Unless either of those modules are being serviced, do not do step 4, "Further disassembly of front-panel assembly."*

1. *Assemble equipment and locate modules to be removed:*
 - a. Have handy a screwdriver with a size T-15 Torx® tip (Items 1 and 2).
 - b. Locate the modules to be removed in the locator diagram *External Modules*, Figure 6–1.
 - c. Do the procedure *Front Cover, Trim Ring, Menu Buttons, and Attenuator Panel*, steps 1–5, immediately preceding this procedure.
2. *Orient the oscilloscope:* Set the oscilloscope so its bottom is down on the work surface and its front is facing you.
3. *Remove the front-panel assembly:*
 - a. Lift the front-panel assembly out of the front subpanel until you can reach the interconnect cable connecting it to the processor/display board.
 - b. Disconnect that cable at J2 of the processor/display board. Disconnect the flex-board connector at P3 of the front-panel assembly. (The flex board is part of the display-frame assembly.) Disconnect cable W76. See Figure 6–8.
 - c. Finally, lift the front-panel assembly out of the front subpanel to complete the removal.

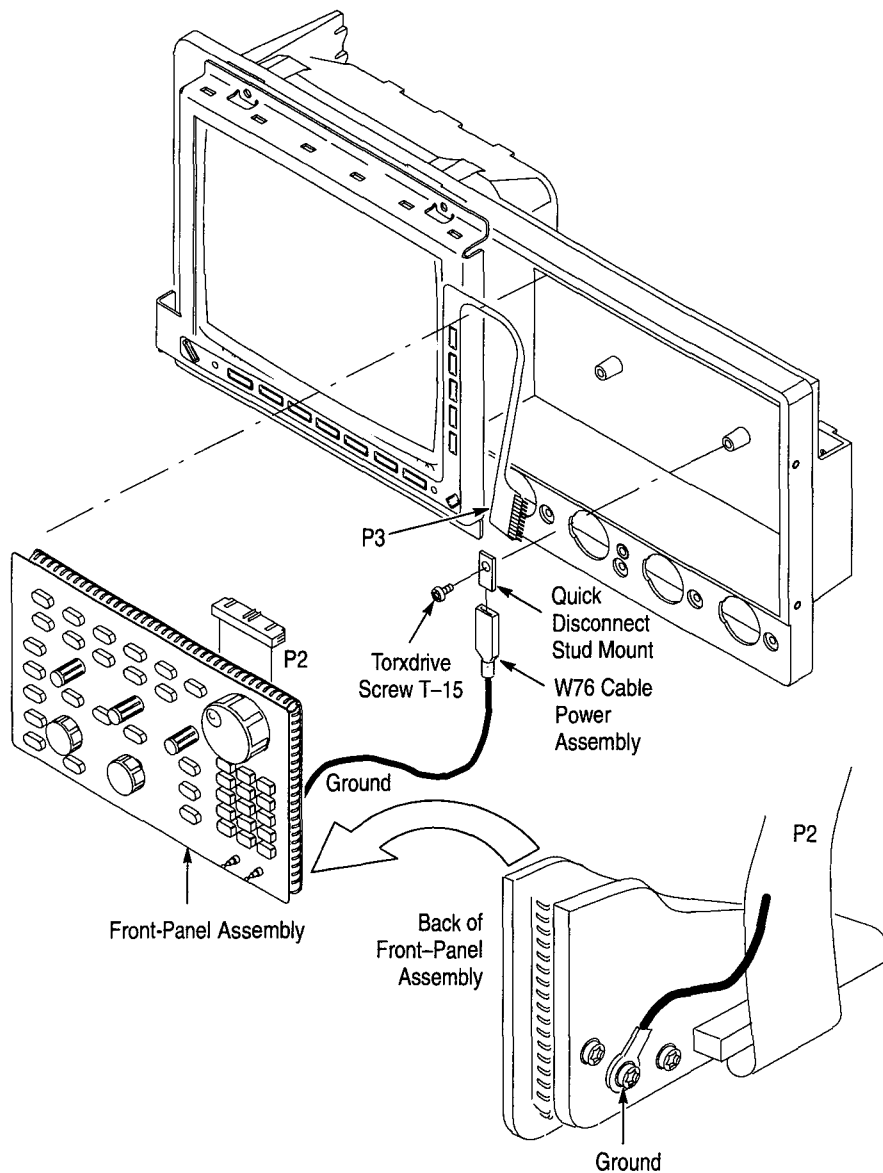

Figure 6–8: A12 Front-Panel Assembly Removal

4. *Further disassembly of front-panel assembly:* If the front panel or the front-panel buttons are to be serviced, do the following substeps:
 - a. Remove the front-panel control knobs from the front-panel assembly using the method described in *Front-Panel Knobs* on page 6–16.
 - b. Remove the eight screws mounting the front-panel board to the front panel.

- c. Now hand disassemble the front-panel assembly components using Figure 6-9 as a guide. Reverse procedure to reassemble, using the same Figure 6-9 as a guide.

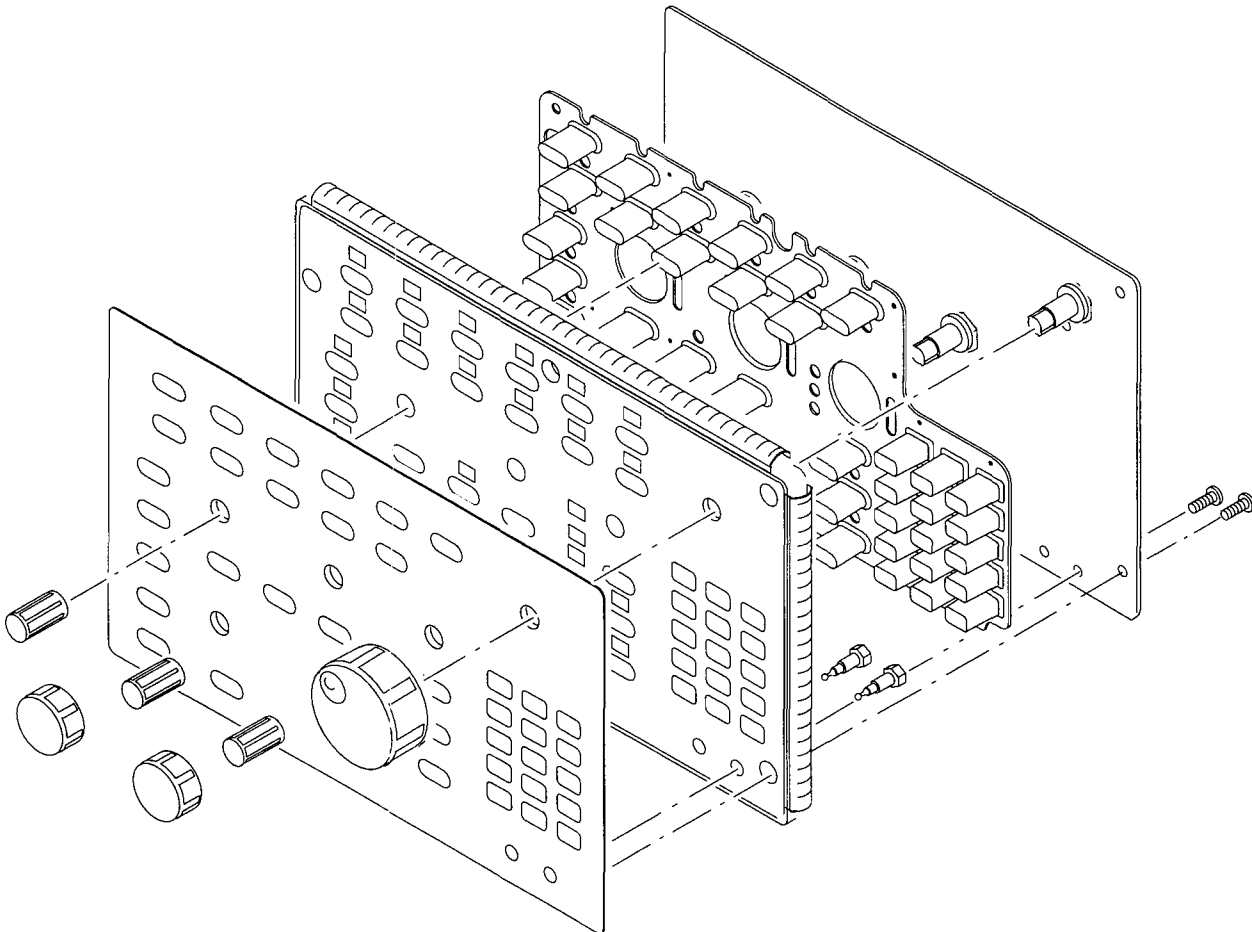

Figure 6-9: Disassembly of Front-Panel Assembly

5. *Reinstallation:* If the front-panel assembly was further disassembled in step 4, then reverse substeps 4a-4c to reassemble, using Figure 6-9 as a guide. Then do step 3, reversing the procedure outlined in each substep. Last, reinstall the trim ring and, if desired, the front cover, referring to the procedure *Front Cover, Trim Ring, Menu Buttons, and Attenuator Panel* (page 6-22).

Display-Frame Assembly

1. *Assemble equipment and locate modules to be removed:* Have handy a screwdriver with a size T-15 Torx® (Items 1 and 2). Locate the modules to be removed in the locator diagram *Outer-Chassis Modules*, Figure 6-2, page 6-13.

2. *Orient the oscilloscope:* Set the oscilloscope so its bottom is down on the work surface and its front is facing you.
3. *Remove the display-frame assembly:*
 - a. Do the procedure *Front Cover, Trim Ring, Menu Buttons, and Attenuator Panel* (page 6–22) to remove the front cover and trim ring.
 - b. Lift the front-panel assembly out of the front subpanel until you can reach J2 on the front-panel assembly. Disconnect the flex cable coming from the display-frame assembly at J39 of the front-panel assembly.
 - c. Do the procedure *Floppy Disk* (page 6–42) to remove the floppy disk drive.
 - d. Remove the three screws securing the display-frame assembly to the front subpanel and remove that assembly.
4. *Reinstallation:*
 - a. Do, in reverse order, substeps 3b–3d, reversing each step to reinstall the display-frame assembly. Then see the procedure *Front Cover, Trim Ring, Menu Buttons, and Attenuator Panel* (page 6–22) to complete reassembly of the oscilloscope.

Cabinet Modules

1. *Assemble equipment and locate modules to be removed:* Have handy a pair of needle-nose pliers (Item 6). Locate the modules to be removed in the locator diagram *External Modules* (see Figure 6–1).
2. *Orient the oscilloscope:* Set the oscilloscope so the left side is down on the work surface and its handle is facing upwards.
3. *Remove the handle:*
 - a. Insert the tips of a pair of needle-nose pliers (Item 6) into the hole of either handle cap. Push and hold to depress the handle release.
 - b. While holding the handle released, pull it out of the slot in the handle cap. Repeat procedure to remove the handle from the other handle cap.
 - c. Reverse procedure to reinstall.
4. *Remove the handle caps:*
 - a. Insert the retaining ring pliers (Item 8) into the opening created in the handle cap when you removed the handle.
 - b. While using the pliers to expand the handle cap outward, grasp it and snap it off.

- c. Repeat procedure to remove the remaining cap as needed; push the cap(s) back on to reinstall.
5. *Remove the flip stand:* Grasp the flip stand by both sides near where it joins each flip stand foot. Now compress the flip stand until the flip stand ends clear the flip stand feet to complete the removal.
6. *Remove the flip stand foot (or feet):*
 - a. Do *Rear Cover and Cabinet* procedure (page 6–18) to gain access to inside of the cabinet.
 - b. Working from inside the cabinet, push the two retainers to release the flip stand foot you wish to remove and lift it away from the outside of the cabinet.
 - c. Repeat procedure to remove as many of the remaining feet as needed; insert the two retainers back in their slots in the cabinet and snap into place any flip stand foot removed.
7. *Reinstallation:* If any flip stand feet were removed, reinstall as directed in step 6c; then see *Rear Cover and Cabinet* procedure (page 6–18) to reinstall the rear cover and cabinet. Do in reverse order steps 3 and 5, reversing each step, to reinstall the flip stand, then the handle caps (if removed), then the handle.

Removal and Installation Procedures

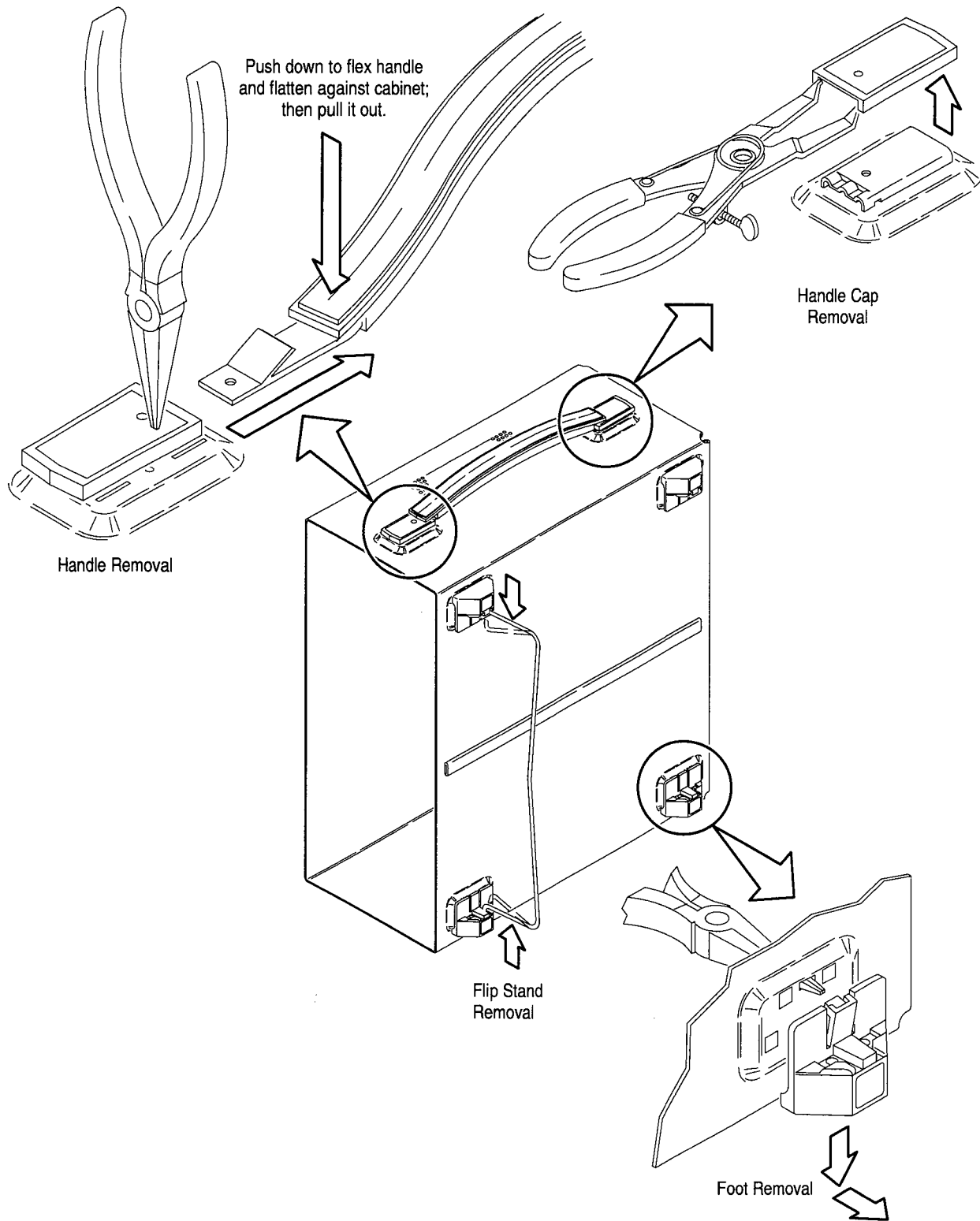

Figure 6-10: Cabinet Modules Removal

Procedures for Outer-Chassis Modules

You should have completed the *Access Procedure* before doing any procedure in this collection. The procedures found here, listed in order presented, follow.

- *Fan*
- *A14 D1 Bus and Analog-Power and Digital-Power Cables*
- *A23 SerPar Board*
- *A29 Video Trigger Board*
- *A11 Processor/Display Board*
- *Top Cover and Board Brackets*
- *Rear-Panel Cables*
- *A10 Acquisition Board*
- *Rear Chassis*

- Fan**
1. *Assemble equipment and locate module to be removed:* Have handy a screwdriver with a size T-20 Torx® tip (Items 1 and 3). Locate the fan in the locator diagram *Outer-Chassis Modules*, Figure 6–2, page 6–13.
 2. *Orient the oscilloscope:* Set the oscilloscope so its bottom is down on the work surface and its left side is facing you.
 3. *Disconnect the fan from processor/display board:* Unplug the fan's power cable from J20.
 4. *Remove the fan:* Remove the two screws securing the fan to the main chassis and lift the fan away from the chassis.
 5. *Reinstallation:* Do in reverse order substeps 3 and 4, reversing the removal instructions in each substep to reinstall the assembly. See the procedure *Rear Cover and Cabinet* (page 6–18) to complete reassembly of the oscilloscope.

A14 D1 Bus and Analog-Power and Digital-Power Cables

1. *Assemble equipment and locate modules to be removed:* Have handy a screwdriver with a size T-15 Torx® tip (Items 1 and 2). Find the modules to be removed in the locator diagram *Outer-Chassis Modules*, Figure 6–2, page 6–13.
2. *Orient the oscilloscope:* Set the oscilloscope so its left side is down on the work surface and its front is facing you.
3. *Remove the D1 bus:* Grasp the D1 bus and pull it up from the oscilloscope to unplug it from its two plug-in connectors. (J28 is the connector on the

processor/display board; J100 is on the acquisition board.) Reverse these removal instructions to reinstall.

4. Remove the analog-power and digital-power interconnect cables:

- a. Unplug the analog-power cable at J26 on the display processor board, at J5 on the low-voltage power supply, and at J700 on the acquisition board.
- b. Unplug the digital-power cable at J27 on the display processor board, at J6 on the low-voltage power supply, and at J101 on the acquisition board.

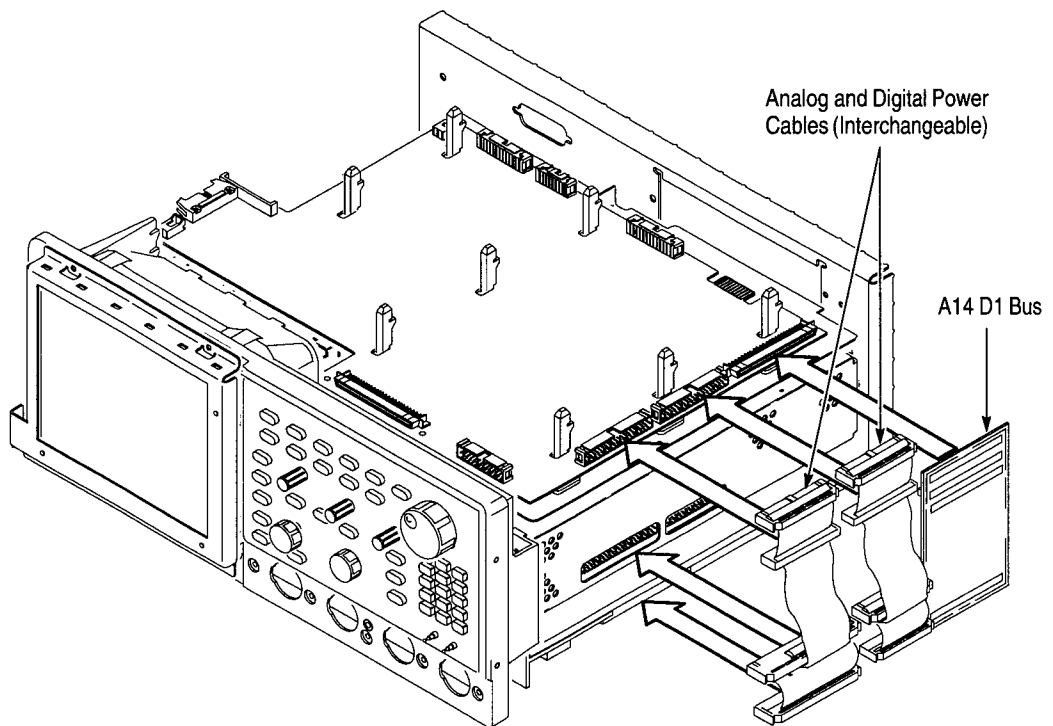

Figure 6-11: A14 D1 Bus and Analog-Power and Digital-Power Cables Removal

5. Reinstallation:

- a. Do in reverse order steps 3 and 4, reversing the procedure outlined in each step to reinstall the assembly.
- b. When installing the D1 bus be sure to orient it so the single connector at the bottom of the bus plugs into the acquisition board.
- c. See the procedure *Rear Cover and Cabinet* (page 6-18) to complete reassembly of the oscilloscope.

**A23 SerPar Board —
RS232/Centronics
Hardcopy Interface**

1. *Remove circuit board assembly:*
 - a. Using a screwdriver with size T-15 Torx® tip, remove the two screws (number 4 in Figure 6-12) securing the rear plate of the circuit board assembly.
 - b. Disconnect the cable connector (number 2) from the processor-display circuit board connector (number 1).
 - c. Pull out the A23 SerPar Board assembly (number 3).

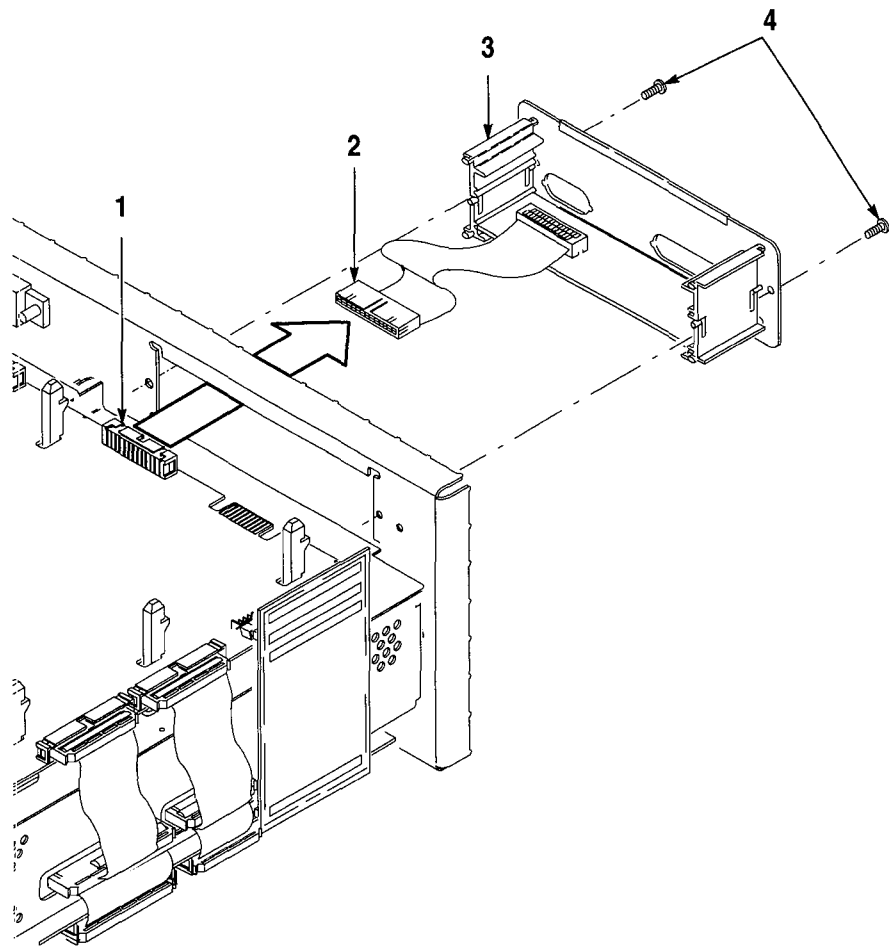
**Figure 6-12: Remove Circuit Board Assembly From Oscilloscope**

2. *Remove circuit board from assembly:*
 - a. Using a $\frac{3}{16}$ inch nutdriver, remove the four lock connectors (number 3 in Figure 6-13) securing the circuit board to the rear plate.

- b. Separate the circuit board with attached cable (number 1), from the rear plate with attached brackets (number 2).

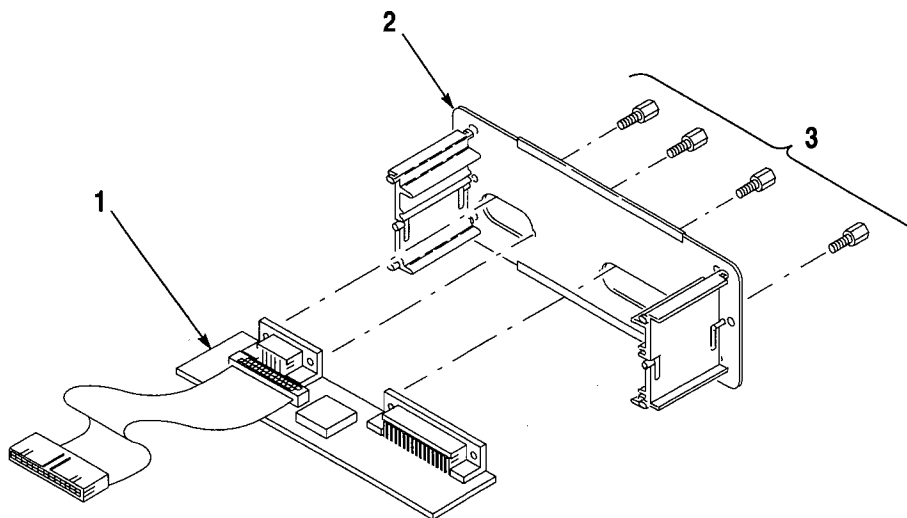

Figure 6-13: Remove Circuit Board From Assembly

3. Replace circuit board:

Equipment Required: One $\frac{3}{16}$ inch nutdriver.

- a. Replace the failed circuit board with a replacement A23 SerPar Board ordered from the factory (see *Replaceable Parts List* for detailed ordering information). Do in reverse order steps a and b of the *Circuit Board Removal From Assembly* procedure on the previous page.
- b. Reinstall the A23 SerPar Board assembly in the oscilloscope. Do in reverse order steps a and b of the *Remove circuit board from assembly* procedure shown above.
- c. Then see the following procedure to complete reassembly of the oscilloscope:
 - *Rear Cover and Cabinet* (page 6-18).
- d. To ensure the A23 SerPar Board is working correctly, perform the power-up short diagnostics procedure described on page 6-57.

A29 Video Trigger Board

Additional modules Removed: D1 bus and analog-and digital-power cables.

1. *Assemble equipment and locate modules to be removed*
 - a. Have handy a screwdriver with a size T-15 Torx® tip (Items 1 and 2).

Removal and Installation Procedures

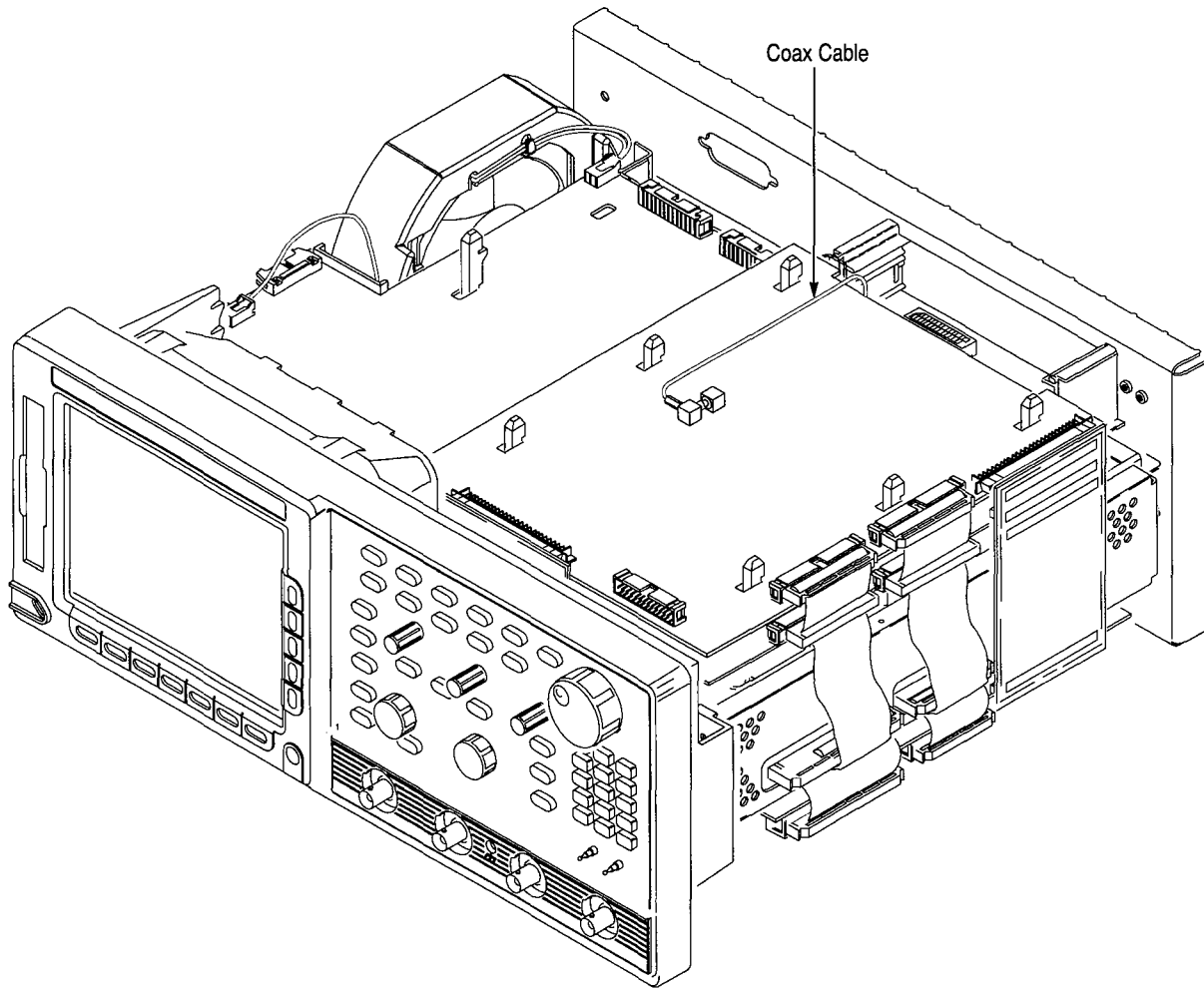

Figure 6-14: Circuit Board Installed

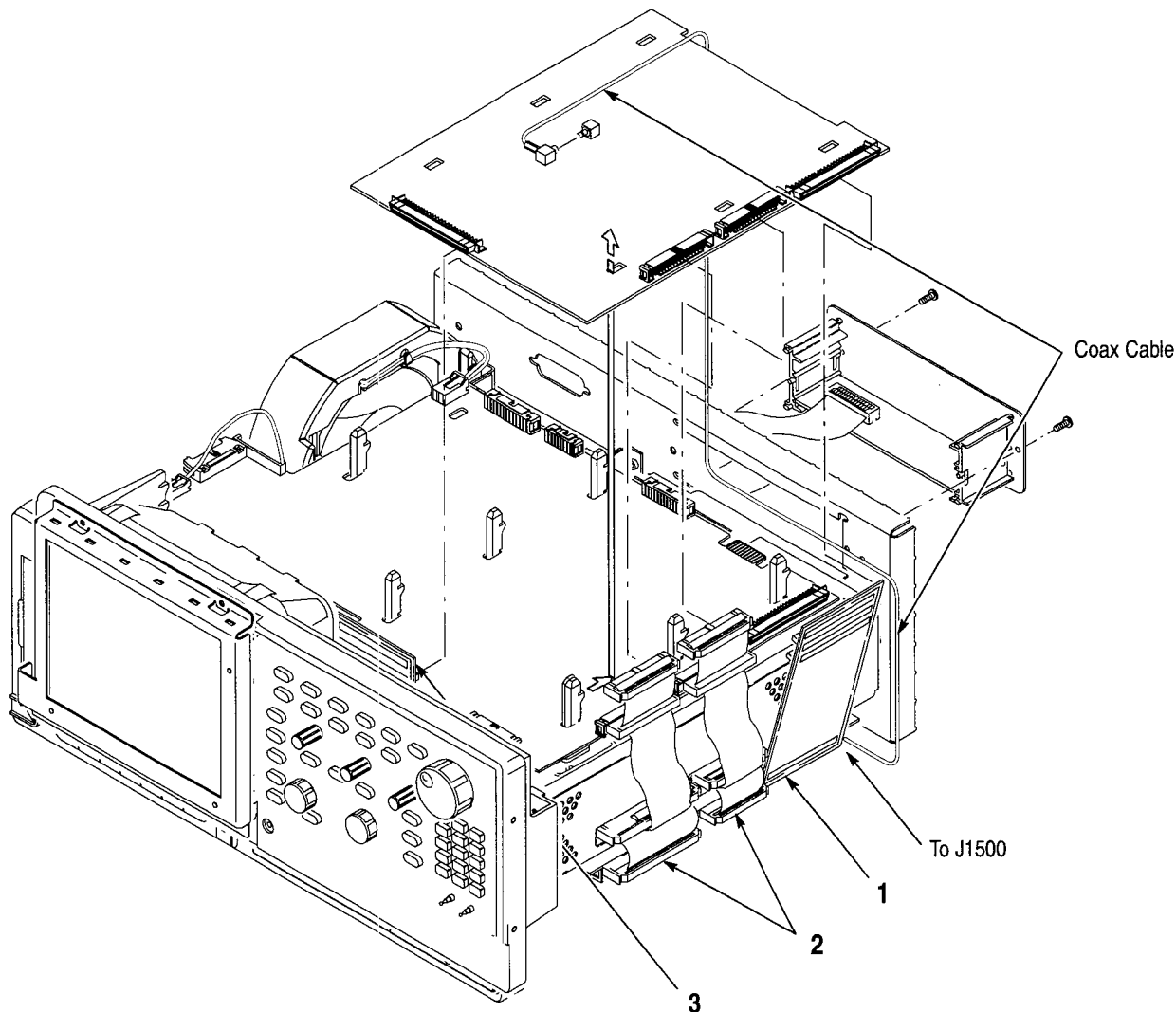

Figure 6-15: Circuit Board Removal

4. *Reinstallation:*

- a. Do, in reverse order, steps a through e. Reverse the removal instructions of each step to reinstall the A29 Video Trigger Board.

NOTE. For the TDS 684A, be sure to arrange the coax cable as shown in Figures 6-14 and 6-15. Failure to do this may impair performance.

Also, when plugging in the digital bus boards, 1 and 3 in Figure 6-15, make sure that they remain plugged in on both ends.

- b. See the procedures *A14 D1 Bus and Analog-Power and Digital-Power Cables* (page 6–29), *A23 SerPar Board* (page 6–31) and *Rear Cover and Cabinet* (page 6–18) to complete reassembly of the oscilloscope.
- c. To ensure the Video Trigger is working correctly, perform the *Diagnostics* procedure on page 6–57.

A11 Processor/Display Board

Additional Modules Removed: D1 bus and analog-and digital-power cables, A23 SerPar Board, and, if option 05 is installed, A29 Video Trigger Board.

1. *Assemble equipment and locate modules to be removed*
 - a. Have handy a screwdriver with a size T-15 Torx® tip (Items 1 and 2).
 - b. Locate the modules to be removed in the locator diagram *Outer-Chassis Modules*, Figure 6–2, page 6–13.
 - c. Do the procedure *A14 D1 Bus and Analog-Power and Digital-Power Cables* that precedes this procedure to remove those interconnect cables.
 - d. Do the procedure *A23 SerPar Board* and, if option 05 is installed, do the procedure *A29 Video Trigger Board*.
2. *Orient the oscilloscope:* Set the oscilloscope so its bottom is down on the work surface and its rear is facing you.
3. *Disconnect the fan from processor/display board:* Unplug the fan's power cable from J20.
4. *Remove the processor/display board:* Use Figure 6–16 as a guide while doing the following substeps:
 - a. Unplug the interconnect cable from the GPIB connector on the rear cover at J35 of the processor/display board. Disconnect the monitor cable at J5. Unplug J62 video signal connector, J51 RS-232 connector, and J38 floppy driver connector.
 - b. Grasp the board by its right and left sides and pull it towards the rear of the oscilloscope. This will disconnect the processor/display board from the eight board mounts securing the board above the top cover.
 - c. Lift the board up away from the oscilloscope chassis to complete the removal.
5. *Reinstallation:*
 - a. Do, in reverse order, steps 3 through 4 reversing the removal instructions of each step to reinstall the processor/display board.
 - b. See the procedures *A14 D1 Bus and Analog-Power and Digital-Power Cables* (page 6–29), *A23 SerPar Board* (page 6–31), if option 05 is

installed, A29 Video Trigger Board, and Rear Cover and Cabinet (page 6-18) to complete reassembly of the oscilloscope.

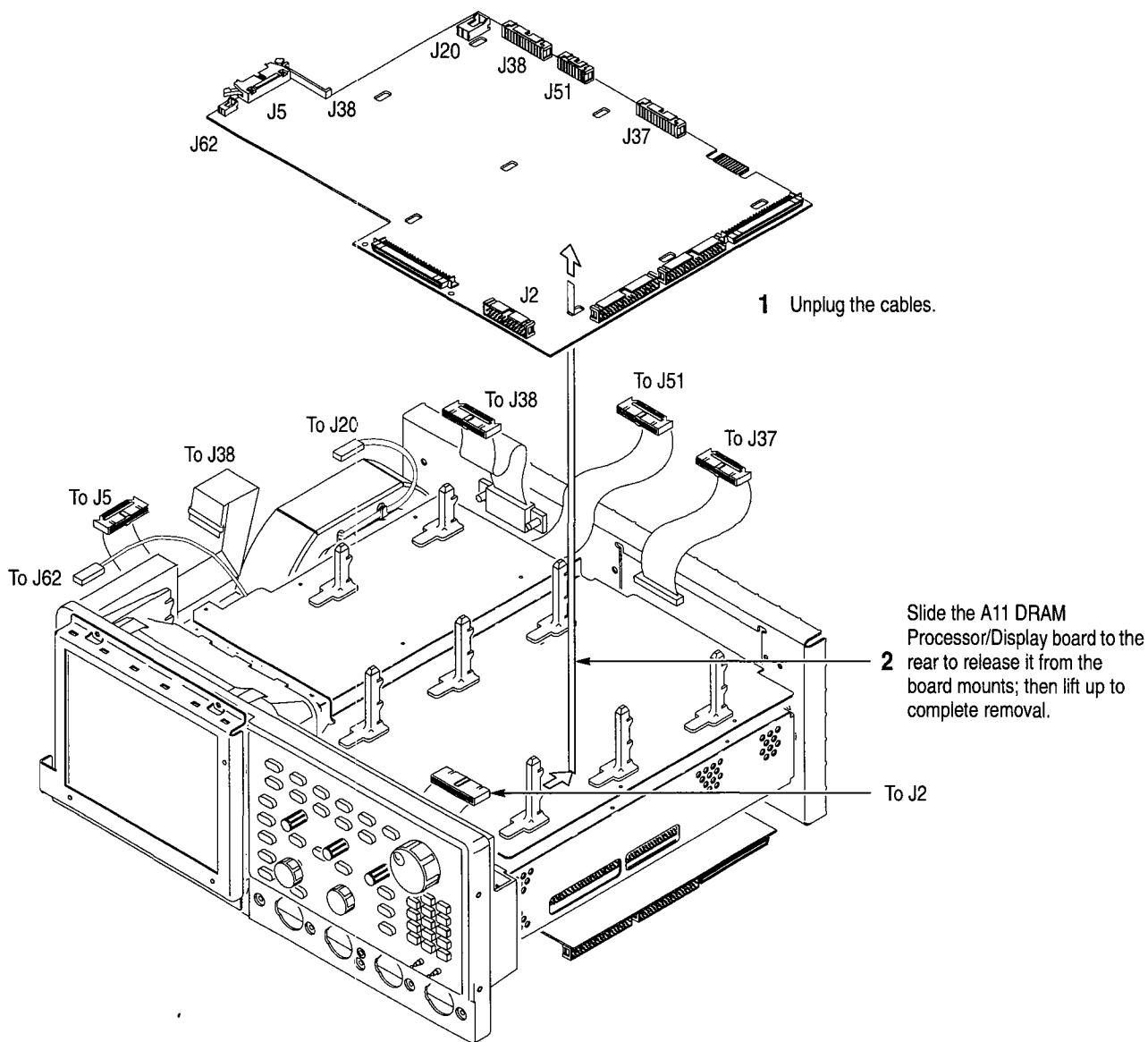

Figure 6-16: A11 Processor/Display Removal

Top Cover and Board Brackets

1. Assemble equipment and locate modules to be removed:

- a. Have handy a screwdriver with a size T-15 Torx® tip (Items 1 and 2) and, if removing any *board mount*, a flat-bladed screwdriver (Item 5).

- b. Locate the modules to be removed in the locator diagram *Outer-Chassis Modules*, Figure 6-2, page 6-13.
- c. Do the procedures *A14 D1 Bus and Analog-Power and Digital-Power Cables* (page 6-29), *A23 SerPar Board* (page 6-31), if option 05 is installed *A29 Video Trigger Board* (page 6-32) and *A11 Processor/Display Board* (page 6-36) to remove those modules.
2. *Orient the oscilloscope:* Set the oscilloscope so its bottom is down on the work surface and its front is facing you.
3. *Remove the top cover:* Remove the 12 screws securing the top cover to the main chassis, then slide it back until its front edge clears the retainers in the front subpanel. Lift the top cover away to complete removal.
4. *Remove the board mount(s):* From the top side of the top cover, use the flat-bladed screwdriver to pry up the retainer lug until it clears the slot in the front cover. While holding the lug clear of the slot, push the mount towards the rear until it releases. (When reinstalling, be sure to align the lug properly and be sure it snaps into its slot.)

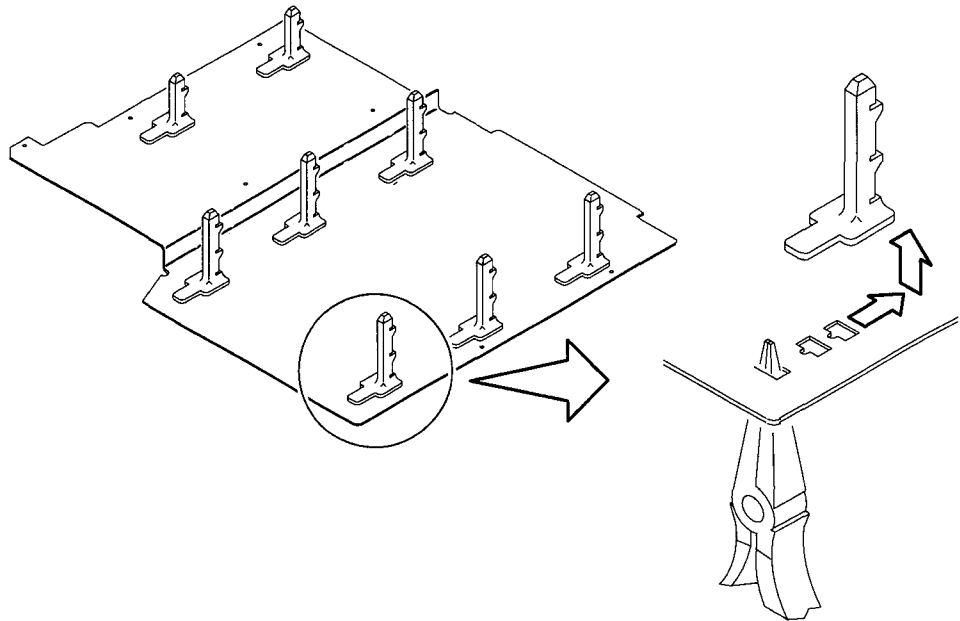

Figure 6-17: Board Bracket Removal

5. *Reinstallation:*
 - a. Do in reverse order steps 3 and 4, reversing the procedure outlined in each step to reinstall the assembly. Then see the following procedures, in the order listed, to complete reassembly of the oscilloscope.

- *All Processor/Display Board* (page 6–36)
- If option 05 is installed, *A29 Video Trigger Board* (page 6–32)
- *A14 D1 Bus and Analog-Power and Digital-Power Cables* (page 6–29)
- *A23 SerPar Board* (page 6–31)
- *Front Cover, Trim Ring, Menu Buttons, and Attenuator Panel* (page 6–22)
- *Rear Cover and Cabinet* (page 6–18)

Rear-Panel Cables

1. *Assemble equipment and locate modules to be removed:* Have handy a pair of needle nose pliers (Item 6). Have handy a ¼ inch nut driver (Item 7).
2. *If removing the GPIB cable, do the following substeps:*
 - a. Unplug the GPIB cable from its jack (J35) of the processor/display board.
 - b. Working from the rear panel and using the ¼ inch nut driver, unscrew the two hex-headed mounting posts that secure the cable to the rear chassis.
 - c. Working from inside the oscilloscope, lift the cable out of the rear chassis.
3. *If removing any cable connected to the rear panel BNC connectors, do the following substeps:*
 - a. Do the procedure *A10 Acquisition Board*, on page 6–39.
 - b. Pull out the cables for SIGNAL OUTPUT, AUX TRIGGER INPUT, MAIN TRIGGER OUTPUT, and DELAYED TRIGGER OUTPUT from J1201, J1001, J1000, and J1550 on A10.
4. *Reinstallation:* Reverse substeps in step 2 and 3 to reinstall any cables removed.

A10 Acquisition Board

1. *Assemble equipment and locate modules to be removed:*
 - a. Have handy a screwdriver with a size T-15 Torx® tip (Items 1 and 2).
 - b. Locate the modules to be removed, including those listed under *Additional Modules Removed* in the locator diagram *Outer-Chassis Modules*, Figure 6–2, page 6–13.
 - c. Do the procedure *A14 D1 Bus and Analog-Power and Digital-Power Cables* (page 6–29) to remove the D1 bus and the interconnect cables.

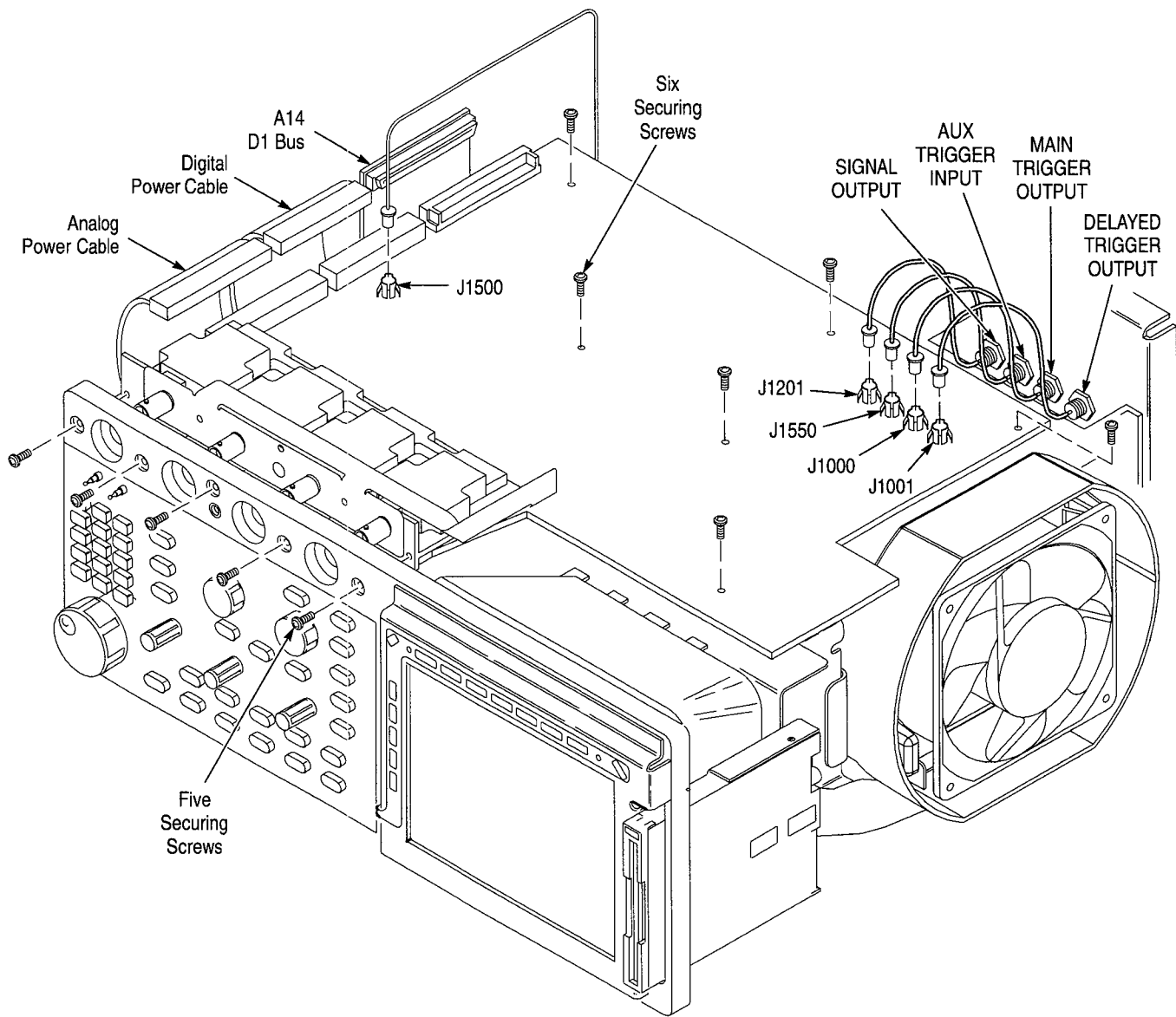

Figure 6-18: A10 Acquisition Board Removal

- Floppy Disk**
1. *Assemble equipment and locate modules to be removed:*
 - a. Have handy a screwdriver with a small Phillips head.
 - b. Locate the modules to be removed, including those listed under *Additional Modules Removed* in the locator diagram *Outer-Chassis Modules*, Figure 6-2, page 6-13.
 2. Do the procedure *Front Cover, Trim Ring, Menu Buttons, and Attenuator Panel* (page 6-22)
 3. *Orient the oscilloscope:* Set the oscilloscope so its top is down on the work surface and its front is facing you.
 4. *Remove the Floppy Disk:* Use Figure 6-19 as a guide.
 - a. Unplug the J38 floppy driver connector (ribbon interconnect cable) that connect the disk drive to the A11 Processor/Display board.
 - b. Remove the disk drive by unscrewing the two retaining Phillips screens on the sides of the disk. Then pull out the disk.

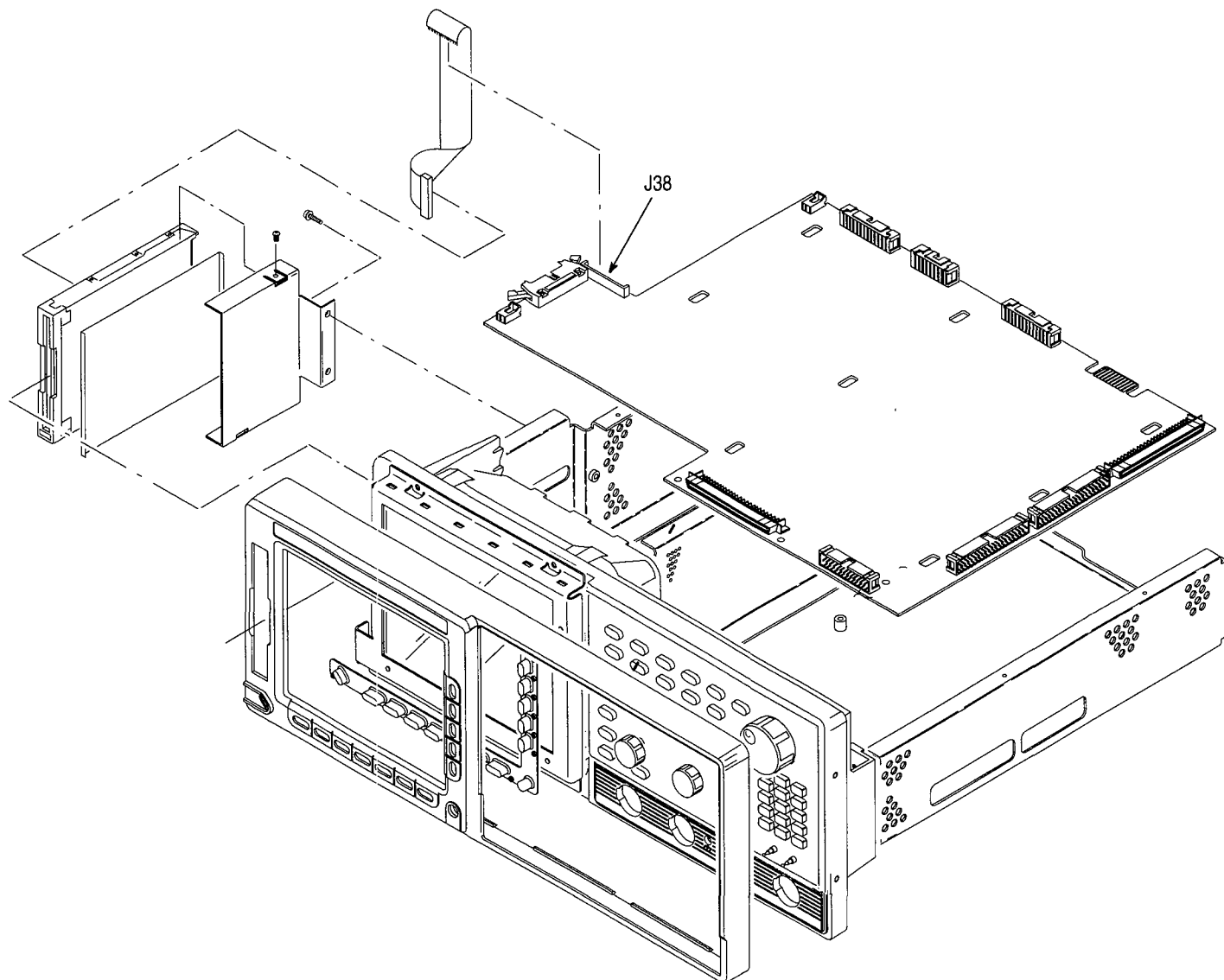

Figure 6-19: Floppy Disk Removal

5. *Reinstallation:* Do, in reverse order, substeps 4b then 4a to reinstall the floppy disk. Then see the following procedures, in the order listed, to complete reassembly of the oscilloscope:
 - *Front Cover, Trim Ring, Menu Buttons, and Attenuator Panel* (page 6-22).
 - *Rear Cover and Cabinet* (page 6-18).

Rear Chassis

1. *Assemble equipment and locate modules to be removed:*
 - a. Have handy a screwdriver with a size T-15 Torx® tip (Items 1 and 2).
 - b. Locate the modules to be removed, including those listed under *Additional Modules Removed* in the locator diagram *Outer-Chassis Modules*, Figure 6-2, page 6-13.
 - c. Install the front cover if it's not already installed.
2. *Orient the oscilloscope:* Set the oscilloscope so its bottom is down on the work surface and its rear is facing you.
3. *Remove the rear chassis:* Use Figure 6-20 as a guide when doing the following substeps:
 - a. Unplug the GPIB interconnect cable at J35 of the processor/display board.
 - b. Unplug the video cable at J51 of the processor/display board.
 - c. Remove the 6 screws securing the rear chassis to the main chassis and the two screws securing it to the low-voltage power-supply shield.
 - d. Lift the rear chassis up slightly to access the cables connected to it. Disconnect those cables from (CH 3) SIGNAL OUT (at J1201), AUX TRIG IN (at J1550), MAIN TRIG OUT (at J1000), DELAYED TRIG OUT (at J1001), all found on the acquisition board.
4. *Reinstallation:* Do, in reverse order, substeps 3a-3c, reversing each step to reinstall the rear chassis. Then see the following procedures, in the order listed, to complete reassembly of the oscilloscope.
 - *A14 D1 Bus and Analog-Power and Digital-Power Cables* (page 6-29)
 - *Rear Cover and Cabinet* (page 6-18)

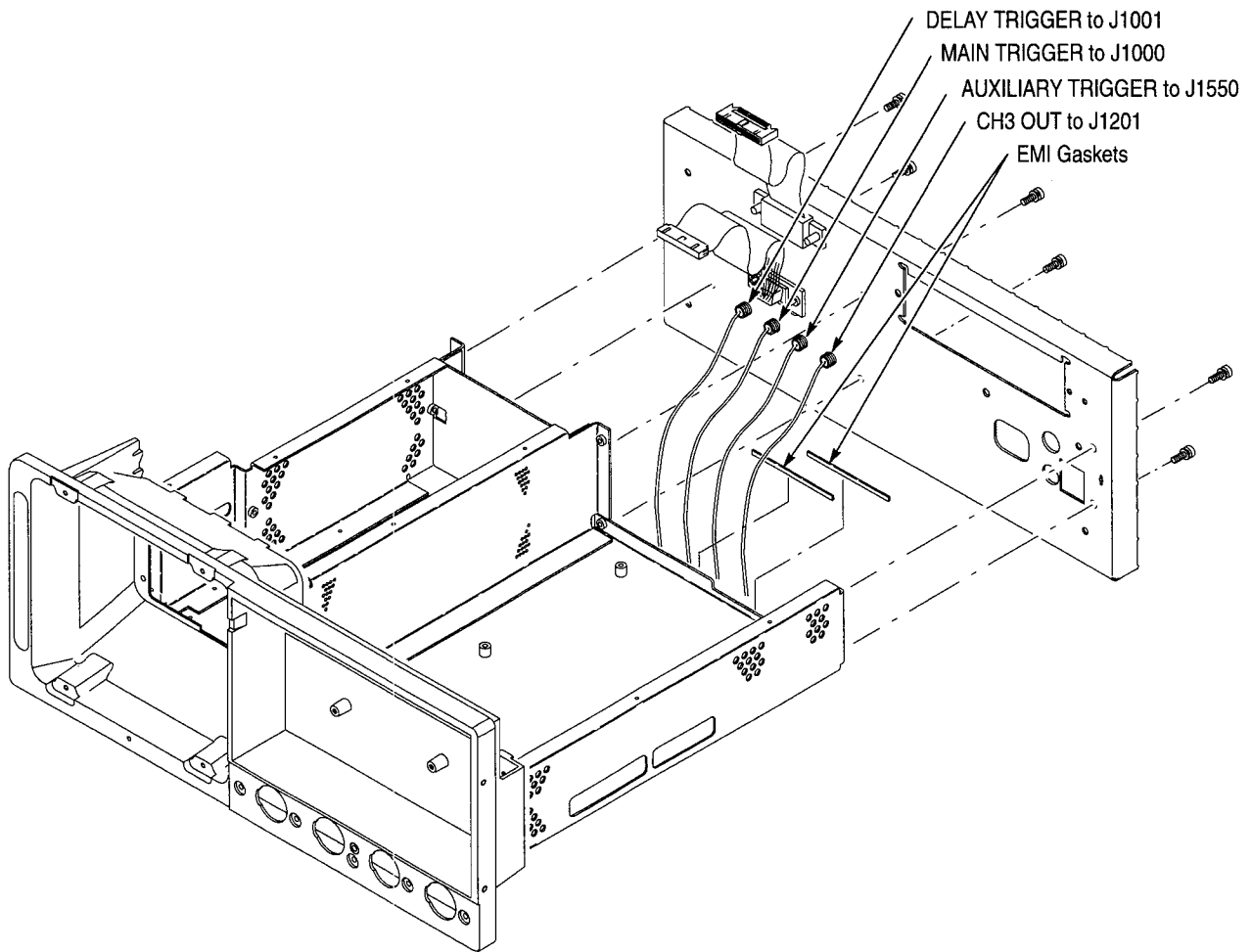

Figure 6-20: Rear Chassis Removal

Procedures for Inner-Chassis Modules

You should have completed the *Access Procedure* (page 6–15) before doing any of the procedures for the Inner-Chassis modules. The procedures are presented in the following order:

A16 Low Voltage Power Supply

A30 Display Assembly and Supply Fuse

Front Subpanel

Main Chassis

A16 Low Voltage Power Supply

1. *Assemble equipment and locate modules to be removed:* Have handy a screwdriver with a size T-15 Torx® tip (Items 1 and 2). Locate the modules to be removed in the locator diagram *Inner-Chassis Modules*, Figure 6–2, page 6–13.
2. *Orient the oscilloscope:* Set the oscilloscope so its bottom is down on the work surface and its rear is facing you.
3. *Remove the low-voltage power supply:*



CAUTION. *If any RTV Silicon is removed from the oscilloscope, it must be replaced in order to maintain the warranted characteristics for random vibration.*

- a. Working from the rear of the oscilloscope, remove the two screws securing the low-voltage power supply to the rear chassis. See Figure 6–21.
 - b. Now, working from the top of the oscilloscope, remove the seven screws, indicated in Figure 6–21, that mount the supply to the main chassis.
 - c. Grasp the supply at the points indicated in Figure 6–21 and lift the board up out of the oscilloscope to complete removal.
4. *Reinstallation:* Do, in reverse order, substeps 3a through 3c reversing each step to reinstall the low-voltage power supply. Then see the following procedures to complete the reassembly:
 - *Top Cover and Board Brackets* (page 6–37)
 - *All Processor/Display Board* (page 6–36)
 - If option 05 is installed, *A29 Video Trigger Board* (page 6–32)

- *A14 D1 Bus and Analog-Power and Digital-Power Cables* (page 6-29)
- *Rear Cover and Cabinet* (page 6-18)

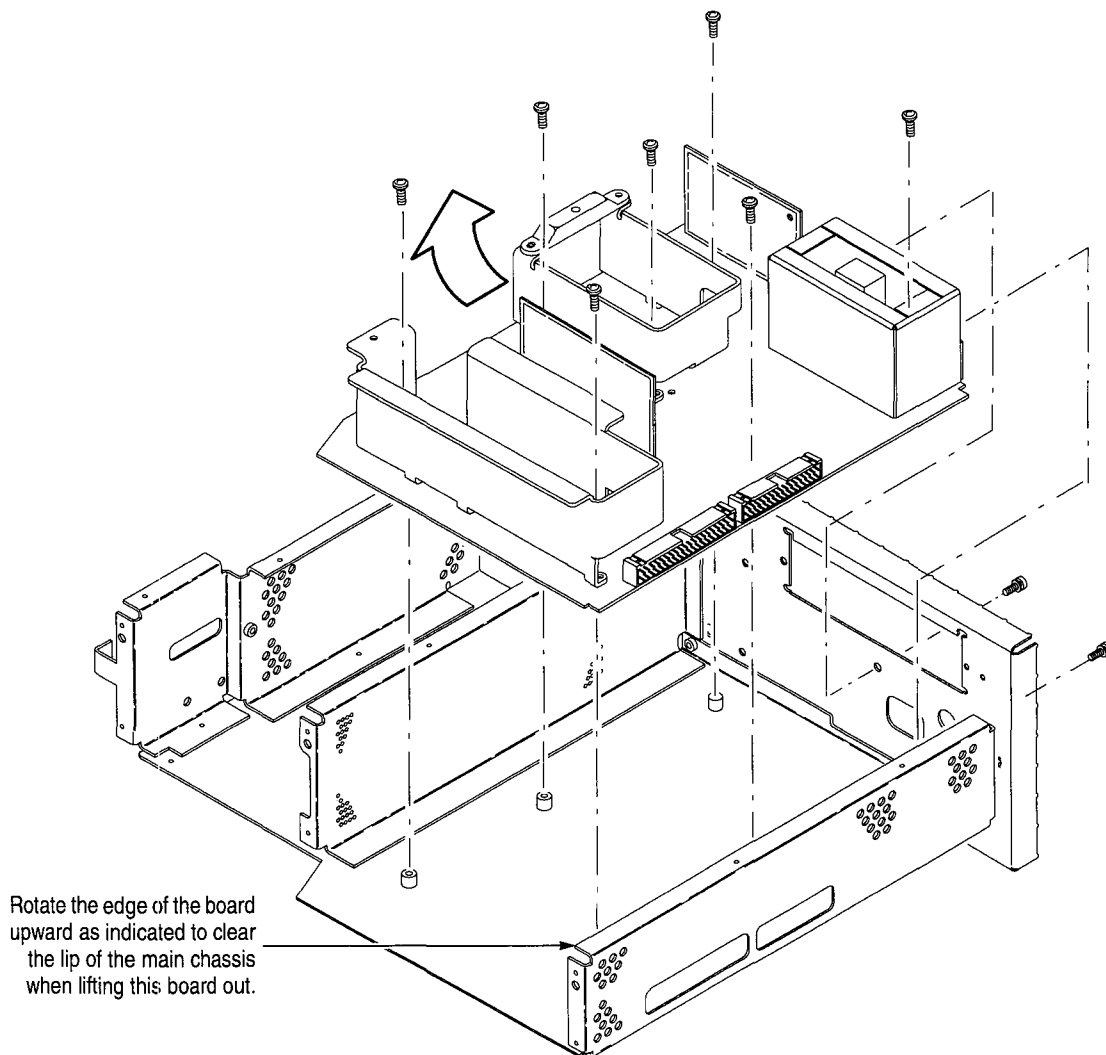

Figure 6-21: A16 Low Voltage Power Supply Removal

A30 Display Assembly and Supply Fuse

NOTE. *The display and the display-driver board are a single module and must be removed and replaced as such. They are listed as a single module in the Replaceable Parts List.*

1. *Assemble equipment and locate modules to be removed:* Have handy a screwdriver with a size T-15 Torx® tip (Items 1 and 2). Locate the modules to be removed in the locator diagram *Inner-Chassis Modules*, Figure 6-2, page 6-13.
2. *Orient the oscilloscope:* Set the oscilloscope so its bottom is down on the work surface and its rear is facing you.
3. *Remove the high-voltage fuse:* If you are servicing this fuse, remove the fuse from its fuse holder. Reverse the procedure to reinstall.



WARNING. Display tube handling: Use care when handling a display tube. If you break a display tube it may implode, scattering glass fragments with high velocity and possibly injuring you. Wear protective clothing, including safety glasses (preferably a full-face shield). Avoiding striking the display tube with or against any object.

Display tube storage: Store the display tube face down in a protected location, placing it on a soft, nonabrasive surface to prevent scratching the face plate.

4. *Remove the display tube:*
 - a. Take the precautions outlined in the warning above. Reference Figure 6-22 while doing the following substeps.
 - b. Unplug the display tube connector from the back of the display tube and the display tube yoke connector from the display circuit board (J170, J305 and J570). Loosen the screw on the video board that holds the CRT sockets. Then pull back on the video board slightly. This separates the board from the socket.
 - c. Remove the two screws that secure the band circling the front of display tube to the front subpanel. Carefully guide display tube forward to partially remove it from the front subpanel and to access the anode lead connected to the display tube.



WARNING. High-voltage is present on the anode lead. Before unplugging the anode in the following substep, you must discharge it: ground a flat-bladed screwdriver (Item 5) with an insulated handle to the chassis through a suitable grounding strap. Next, probe under the insulating cap of the anode lead and touch the lead's metal conductor to discharge. Repeat. After unplugging the anode in substep d, touch its metal conductor to the chassis for a few minutes to further ensure discharge.

- d. Discharge the anode lead as described in the immediately preceding **WARNING**, unplug it from the display tube, and discharge that lead (again see **WARNING**).

- e. Be sure you have read the **WARNING** on display tube handling and storage found at the start of this display tube removal procedure. Then pull the display tube out through the front subpanel to complete removal. Store as directed in the previous **WARNING** message.

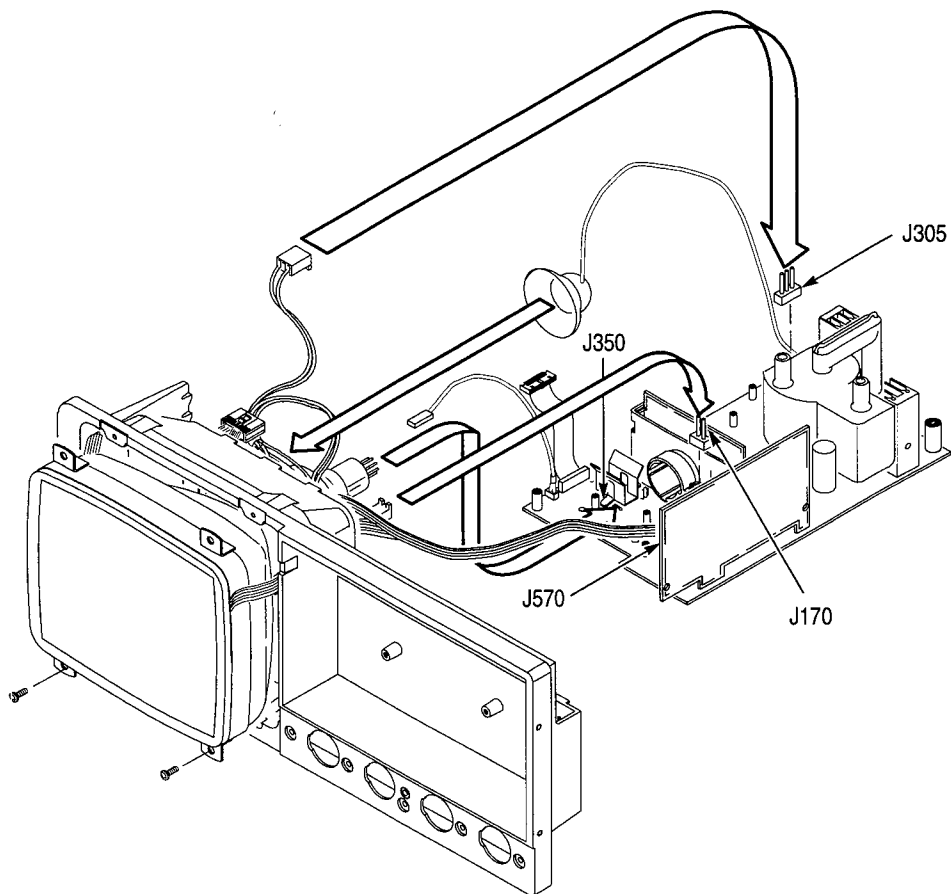

Figure 6-22: Display Assembly Removal

5. Remove the display supply board: Use Figure 6-23 as a guide.



CAUTION. If any RTV Silicon is removed from the oscilloscope, it must be replaced in order to maintain the warranted characteristics for random vibration.

- a. Remove the six screws that mount the display-driver board to the main chassis.

- *Top Cover and Board Brackets* (top cover only) on page 6–37
- *All Processor/Display Board* (page 6–36)
- If option 05 is installed, *A29 Video Trigger Board* (page 6–32)
- *A14 D1 Bus and Analog-Power and Digital-Power Cables* (page 6–29)
- *Display-Frame Assembly*
- *Front Cover, Trim Ring, Menu Buttons, and Attenuator Panel* (page 6–22)
- *Rear Cover and Cabinet* (page 6–18) (completes reassembly)

Front Subpanel

1. *Assemble equipment and locate modules to be removed:*
 - a. Have handy a screwdriver with a size T-15 Torx® tip (Items 1 and 2).
 - b. Do the procedure *A30 Display Assembly and Supply Fuse* (page 6–47). Do not remove the display-driver board.
 - c. Locate the modules to be removed in the locator diagram *Inner-Chassis Modules*, Figure 6–2, page 6–13.
2. *Orient the oscilloscope:* Set the oscilloscope so its rear is down on the work surface and its bottom is facing you.
3. *Remove the front subpanel:* Remove the six screws securing the front subpanel to the main chassis. (See Figure 6–24 for screw locations.) Lift the front subpanel up away from the main chassis to complete the removal.
4. *Reinstallation:* Do the following substeps to reinstall the front subpanel and reassemble the remainder of the oscilloscope:
 - a. Align the front subpanel to the main chassis, taking care to ensure that the main chassis slips into its alignment slot on the front subpanel (see magnified view, Figure 6–24.) Then reinstall the six screws removed in step 3.
 - b. See the procedure *A30 Display Assembly and Supply Fuse* (page 6–47) to reinstall the display-frame assembly and display tube.
 - c. See the following procedures, in the order listed, for instructions for reinstalling the remaining modules.
 - *Top Cover and Board Brackets* (page 6–37)
 - *All Processor/Display Board* (page 6–36)
 - If option 05 is installed, *A29 Video Trigger Board* (page 6–32)

- *A14 D1 Bus and Analog-Power and Digital-Power Cables* (page 6–29)
- *Front Cover, Trim Ring, Menu Buttons, and Attenuator Panel* (page 6–22)
- *Rear Cover and Cabinet* (page 6–18)

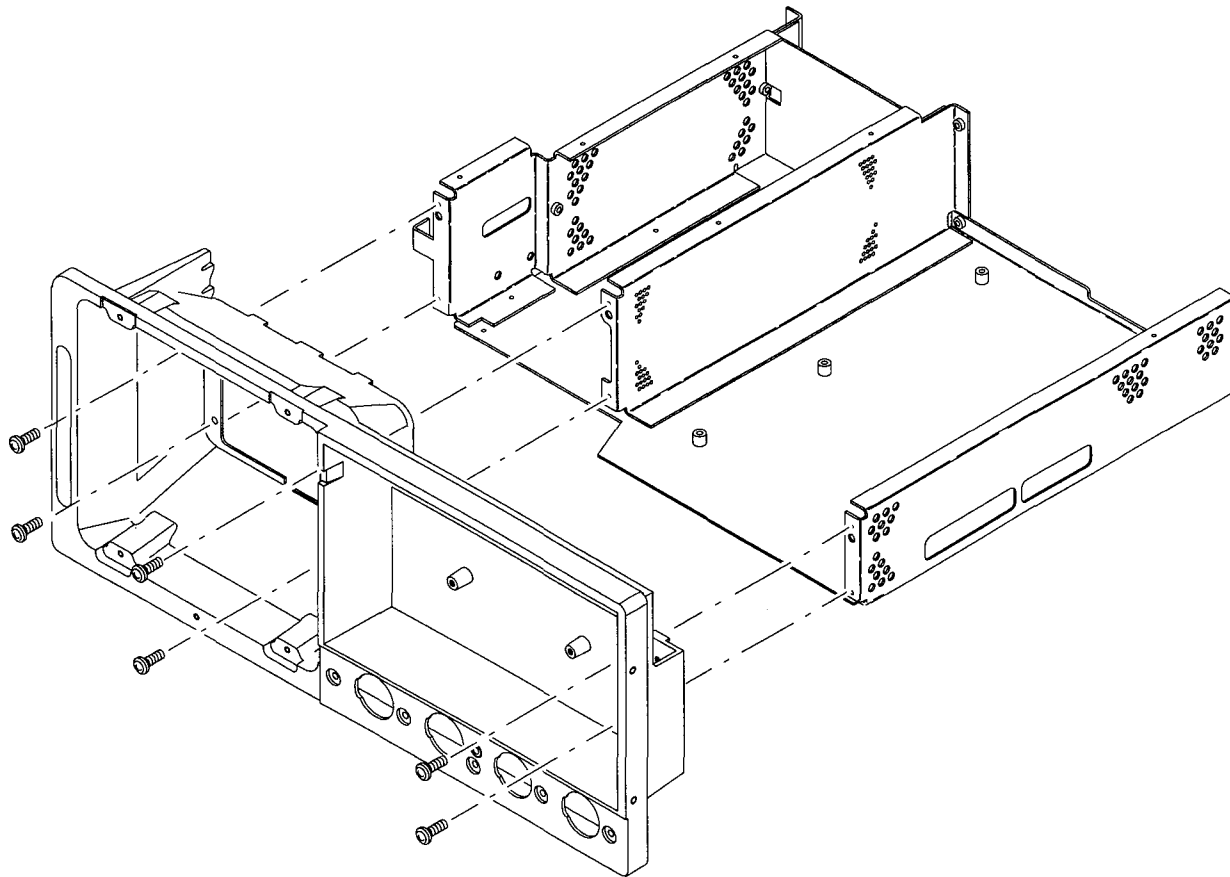

Figure 6–24: Front Subpanel Removal

Main Chassis *Additional Modules Removed: All.*

1. *Remove the main chassis:* Since the removal of the main chassis requires the removal of virtually all modules, do the procedure *Disassembly for Cleaning* that follows. While doing *Disassembly for Cleaning*, you will remove the front-panel assembly. Ignore the instructions to disassemble that assembly.
2. *Reinstallation:* See reinstallation instructions in *Disassembly for Cleaning*.

Disassembly for Cleaning

This procedure is for disassembly of the Digitizing Oscilloscopes into its individual modules so they can be cleaned. For the cleaning instructions, see *Inspection and Cleaning*, which begins this section.

3. *Assemble equipment and locate modules to be removed:*
 - a. Have handy a screwdriver with a size T-15 Torx® tip (Items 1 and 2), a T-20 Torx® tip (Item 3), a flat-bladed screwdriver (Item 6-11), and a pair of angle-tip tweezers (Item 6-11).
 - b. Familiarize yourself with the modules illustrated in figures 6-1, 6-2, and 6-3.
4. *Remove external modules:* Do in order the following procedures. They are found under *Procedures for External Modules* which starts on page 6-16.
 - a. *Line Fuse and Line Cord* (page 6-17)
 - b. *Rear Cover and Cabinet* (page 6-18)
 - c. *Front Cover, Trim Ring, Menu Buttons, and Attenuator Panel* (page 6-22)
 - d. *Front Subpanel* (page 6-51) and *Display-Frame Assembly*
5. *Remove the outer-chassis modules:* Do in order the following procedures. They are found under *Procedures for Outer-Chassis Modules* which start on page 6-29.
 - a. *Fan* (page 6-29)
 - b. *A14 DI Bus and Analog-Power and Digital-Power Cables* (page 6-29)
 - c. *A23 SerPar Board* (page 6-31)
 - d. *A29 Video Trigger Board – with option 05* (page 6-32)
 - e. *A11 Processor/Display Board* (page 6-36)
 - f. *Top Cover and Board Brackets* (page 6-37)
 - g. *A10 Acquisition Board* (page 6-39)
6. *Remove the inner-chassis modules:* Do in order the following procedures. They are found under *Procedures for Inner-Chassis Modules* which start on page 6-46.
 - a. *A16 Low Voltage Power Supply* (page 6-46)
 - b. *A30 Display Assembly and Supply Fuse* (page 6-47)

7. Disassemble the chassis:

- a. Set the assembly so its bottom is down on the work surface and its front is facing you.
- b. Remove the six screws securing the front subpanel to the main chassis. (See Figure 6–24 for screw location.)
- c. Lift the front subpanel up away from the main chassis.
- d. Now remove the five screws securing the rear chassis to the main chassis and separate the two chassis. (See Figure 6–20 for screw location.)

8. Reassembly: Do the following substeps:

- a. *Reassemble the chassis:* Align the rear chassis to the main chassis and reinstall the five screws removed in step 7; align the front subpanel to the main chassis and reinstall the six screws removed in step 7.

NOTE. *The following substeps refer you to procedures for installing each module removed. When reinstalling the modules, ignore any instructions that require connecting a cable or bus to an module that you have not yet installed. The necessary connections will be made when you install the missing module later.*

- b. *Reinstall the inner-chassis modules:* Do in the order listed the following procedures. When doing these procedures, do their steps in reverse order. These procedures are found under *Procedures for Inner-Chassis Modules* which start on page 6–46.
 - *A30 Display Assembly and Supply Fuse* (page 6–47)
 - *A16 Low Voltage Power Supply* (page 6–46)
- c. *Reinstall the outer-chassis modules:* Do in the order listed the following procedures. When doing these procedures, do their steps in reverse order. These procedures are found under *Procedures for Outer-Chassis Modules* which start on page 6–29.
 - *Top Cover and Board Brackets* (page 6–37)
 - *A11 Processor/Display Board* (page 6–36)
 - *A23 SerPar Board* (page 6–31)
 - *A29 Video Trigger Board – with option 05* (page 6–32)
 - *A14 D1 Bus and Analog-Power and Digital-Power Cables* (page 6–29)
 - *Fan* (page 6–29)

- *A10 Acquisition Board* (page 6–39)
- d. *Reinstall external modules:* Do in the order listed the following procedures. When doing these procedures, do the steps in reverse order. These procedures are found under *Procedures for External Modules* which starts on page 6–16.
 - *Front Subpanel* (page 6–51)
 - *Display-Frame Assembly* (page 6–47)
 - *Front Cover, Trim Ring, Menu Buttons, and Attenuator Panel* (page 6–22)
 - *Rear Cover and Cabinet* (page 6–18)
 - *Line Fuse and Line Cord* (page 6–17)

Removal and Installation Procedures

Troubleshooting

This subsection contains information and procedures designed to help you isolate faulty modules in the oscilloscope. If a module needs to be replaced, follow the *Removal and Installation Procedures* located in this section.

Diagnostics

The oscilloscope has two levels of internal diagnostics that focus on verifying, adjusting, and if need be, isolating faulty modules.

Both levels of internal diagnostics report any bad modules and/or interfaces. If a bad module and/or interface is found, use the troubleshooting procedures in this section to determine which module needs to be replaced.

The two levels of diagnostics are the short confidence set and the extended set that tests the oscilloscope circuitry in depth and takes more time. At power-on, the oscilloscope automatically executes the short set. The extended set is optional and is executed by using the following procedure:

Prerequisites: Power on the oscilloscope and allow a 20 minute warm-up before doing this procedure.

1. *Display the System diagnostics menu:*
 - a. Press **SHIFT**; then press **UTILITY**.
 - b. Repeatedly press the main-menu button **System** until **Diag/Err** is highlighted in the pop-up menu.
2. *Run the System Diagnostics:* Press the main-menu button **Execute**; then press the side-menu button **OK Confirm Run Test**.
3. *Wait:* The internal diagnostics do an exhaustive verification of proper oscilloscope function. This verification will take about two minutes. When finished, the oscilloscope will display a report of any bad modules and/or interfaces.



Firmware Updates

Digitizing Oscilloscopes firmware updates are easy to do. Simply install the firmware disks on your PC and follow the instructions in the README file located on the first disk.

NOTE. *You must set the Protection switch to the unprotected position before updating the Firmware. Figure 6-25 shows how to set the switch. After loading the Firmware, be sure you set the switch back to the protected position and cycle power.*

If you want to order a firmware update, see *Optional Accessories, Mechanical Parts List* in Section 10 for the part number.

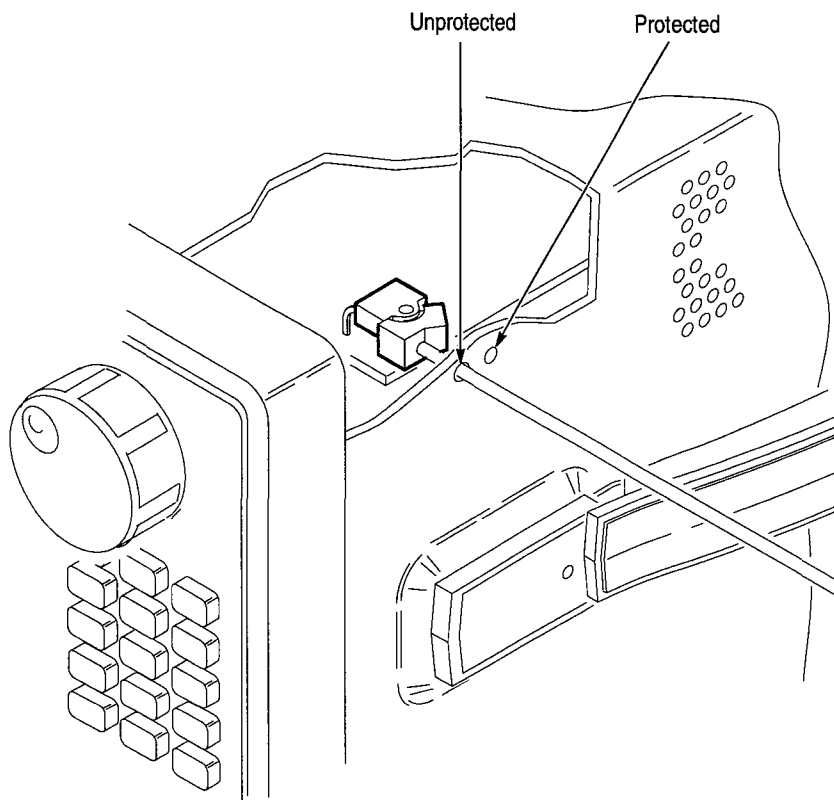

Figure 6-25: Accessing the Protection Switch

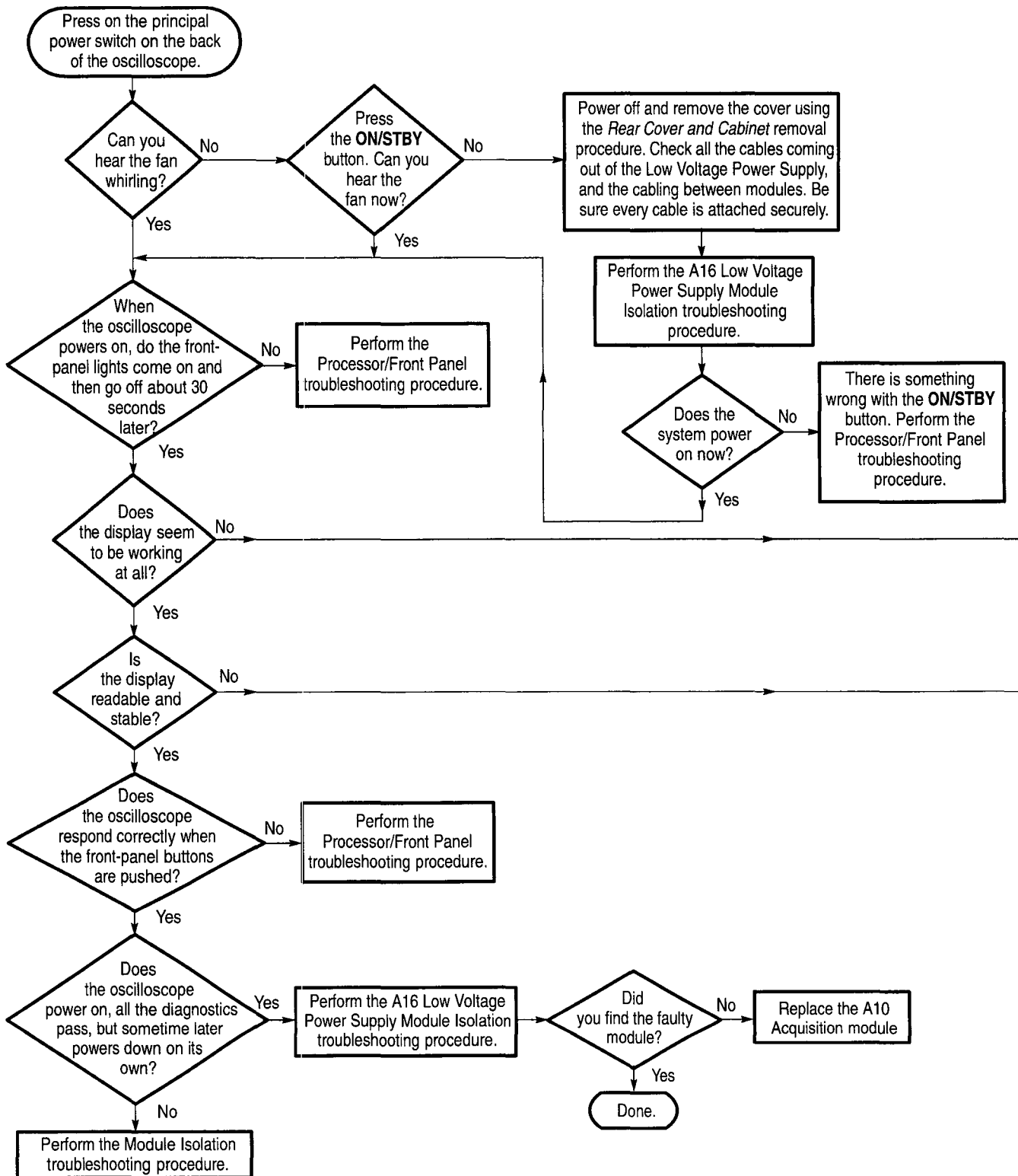

Figure 6-26: Primary Troubleshooting Procedure

Troubleshooting

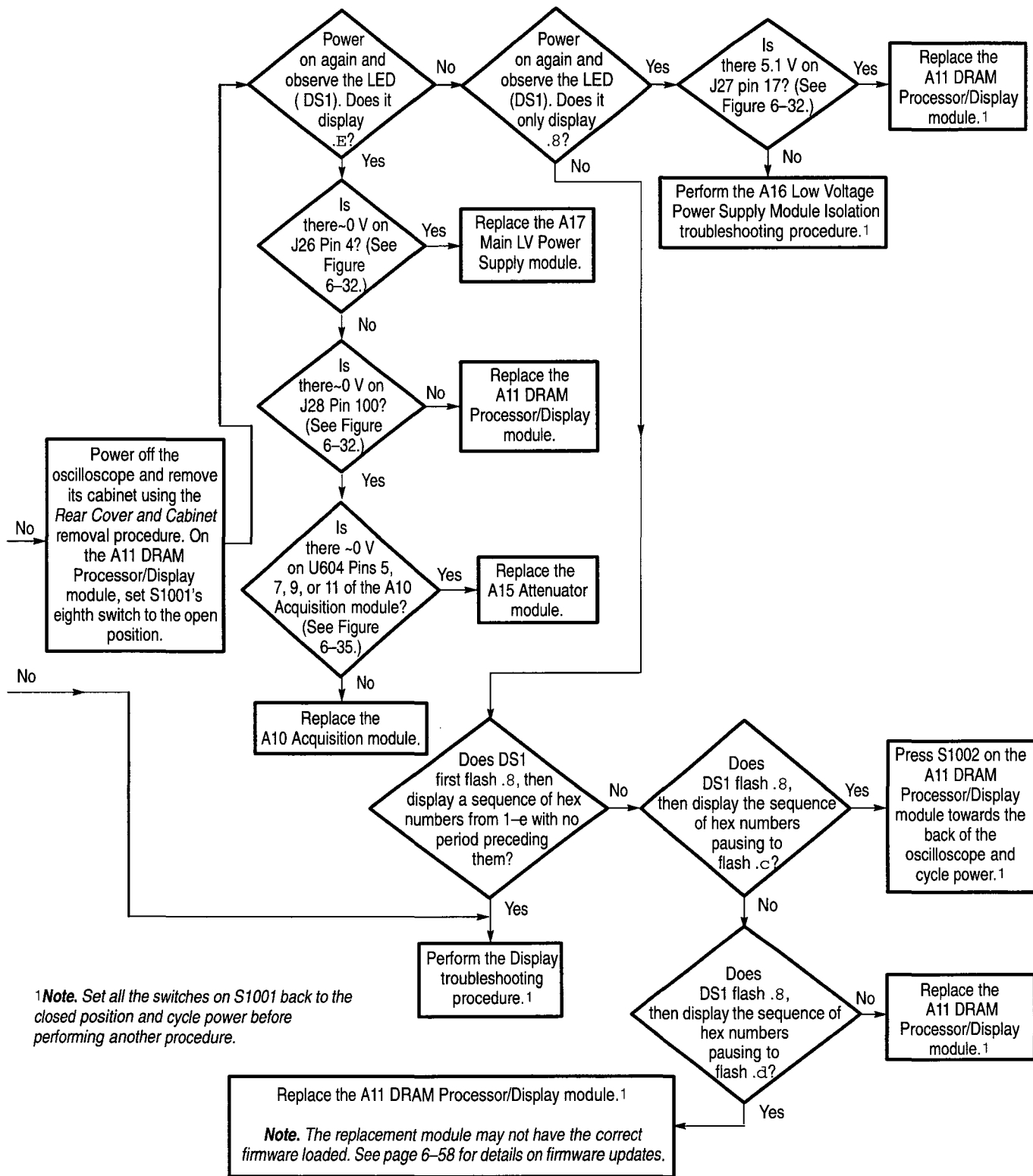

Figure 6-26: Primary Troubleshooting Procedure (Cont.)

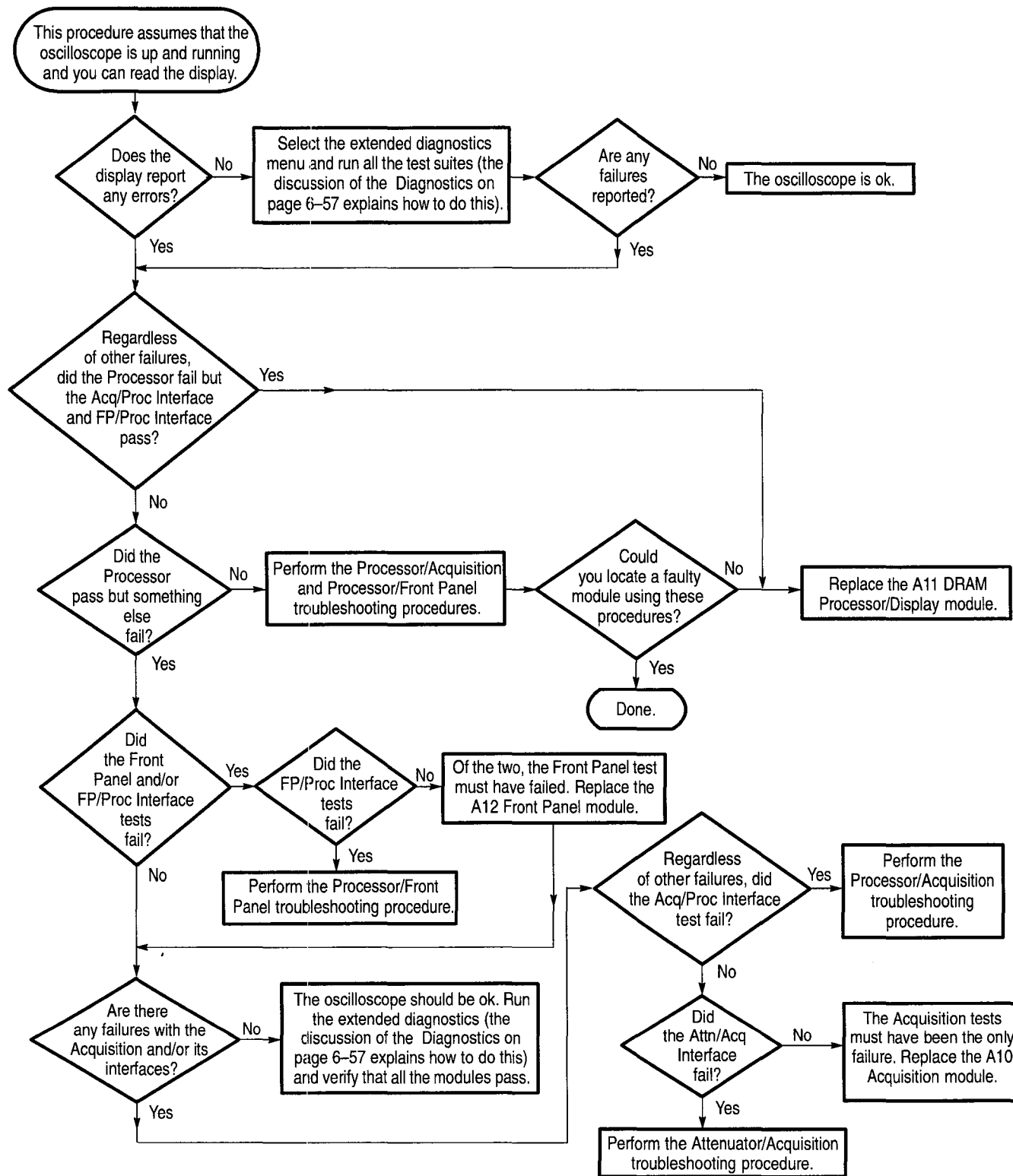

Figure 6-27: Module Isolation Troubleshooting Procedure

Troubleshooting

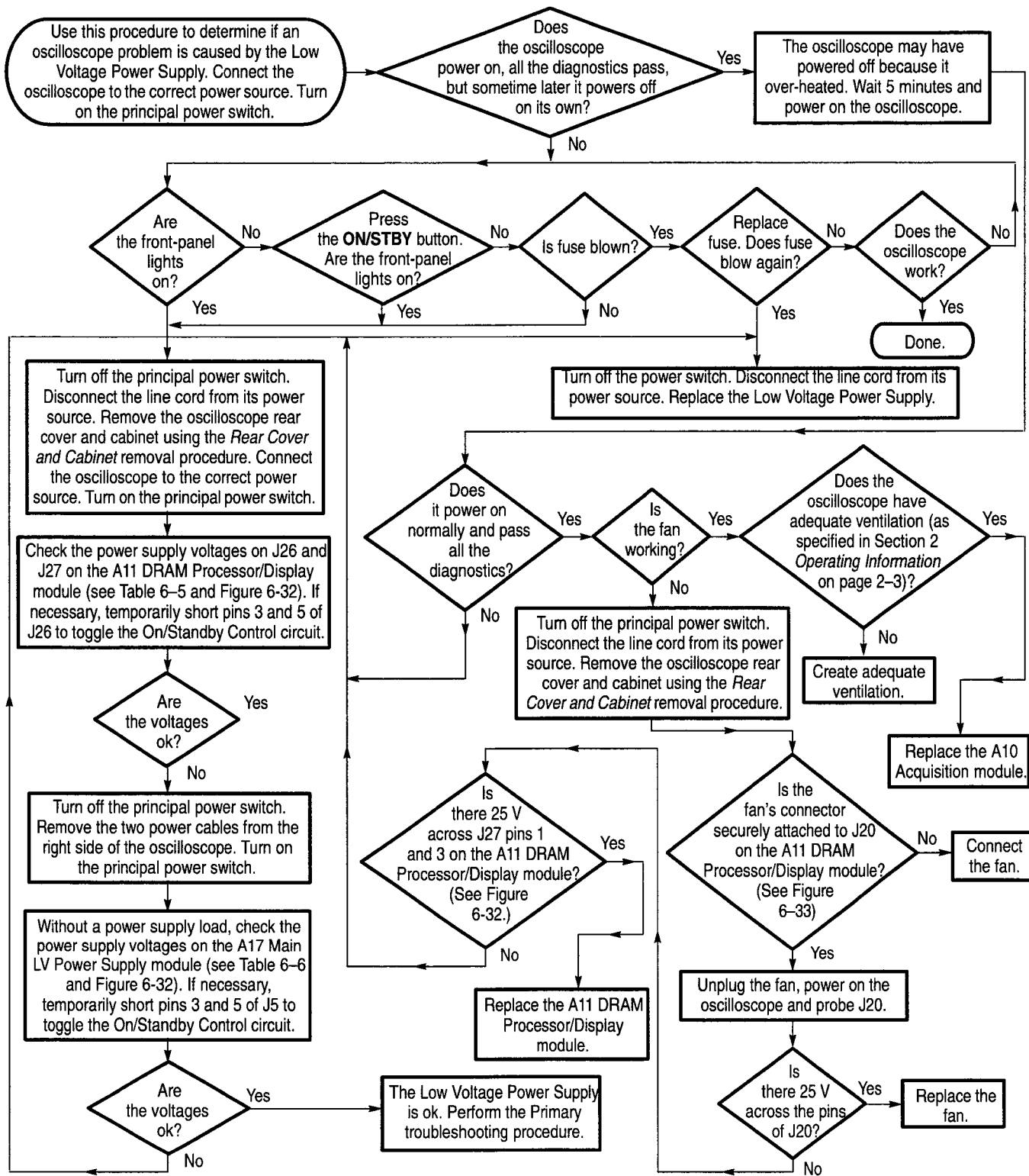

Figure 6-28: A16 Low Voltage Power Supply Module Isolation Troubleshooting Procedure

Table 6–5: Normal Supply Voltages (Measured on J26 and J27 on the A11 DRAM Processor/Display Module)

Supply	Lower Limit	Upper Limit
Ground (J26 or J27 pin 15)		
+5.1 VA (J27 pin 5)	+5.0 V	+5.2 V
+5.1 VB (J27 pin 17)	+5.0 V	+5.2 V
+25 V (J27 pin 1)	+23.5 V	+27.5 V
+5 V (J26 pin 39)	+4.9 V	+5.1 V
–5.1 V (J26 pin 17)	–4.9 V	–5.2 V
+15 V (J26 pin 11)	+14.7 V	+15.3 V
–15 V (J26 pin 7)	–14.7 V	–15.3 V

Table 6–6: No-Load Supply Voltages (Measured on J5 and J6 on the A17 Main LV Power Supply Module)

Supply	Lower Limit	Upper Limit
Ground (J5 or J6 pin 15)		
+5.1 VA (J6 pin 5)	+4.95 V	+5.25 V
+5.1 VB (J6 pin 17)	+4.95 V	+5.25 V
+25 V (J6 pin 1)	+23.5 V	+27.5 V
+5 V (J5 pin 39)	+0.59 V	+0.81 V
–5.1 V (J5 pin 17)	–0.39 V	–0.61 V
+15 V (J5 pin 11)	+1.05 V	+1.75 V
–15 V (J5 pin 7)	–1.05 V	–1.75 V

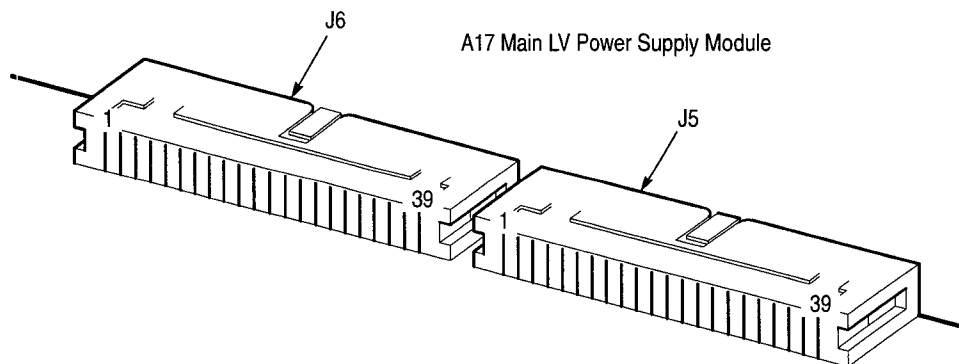
**Figure 6–29: Power Supply Voltage Measurement Locations**

Troubleshooting

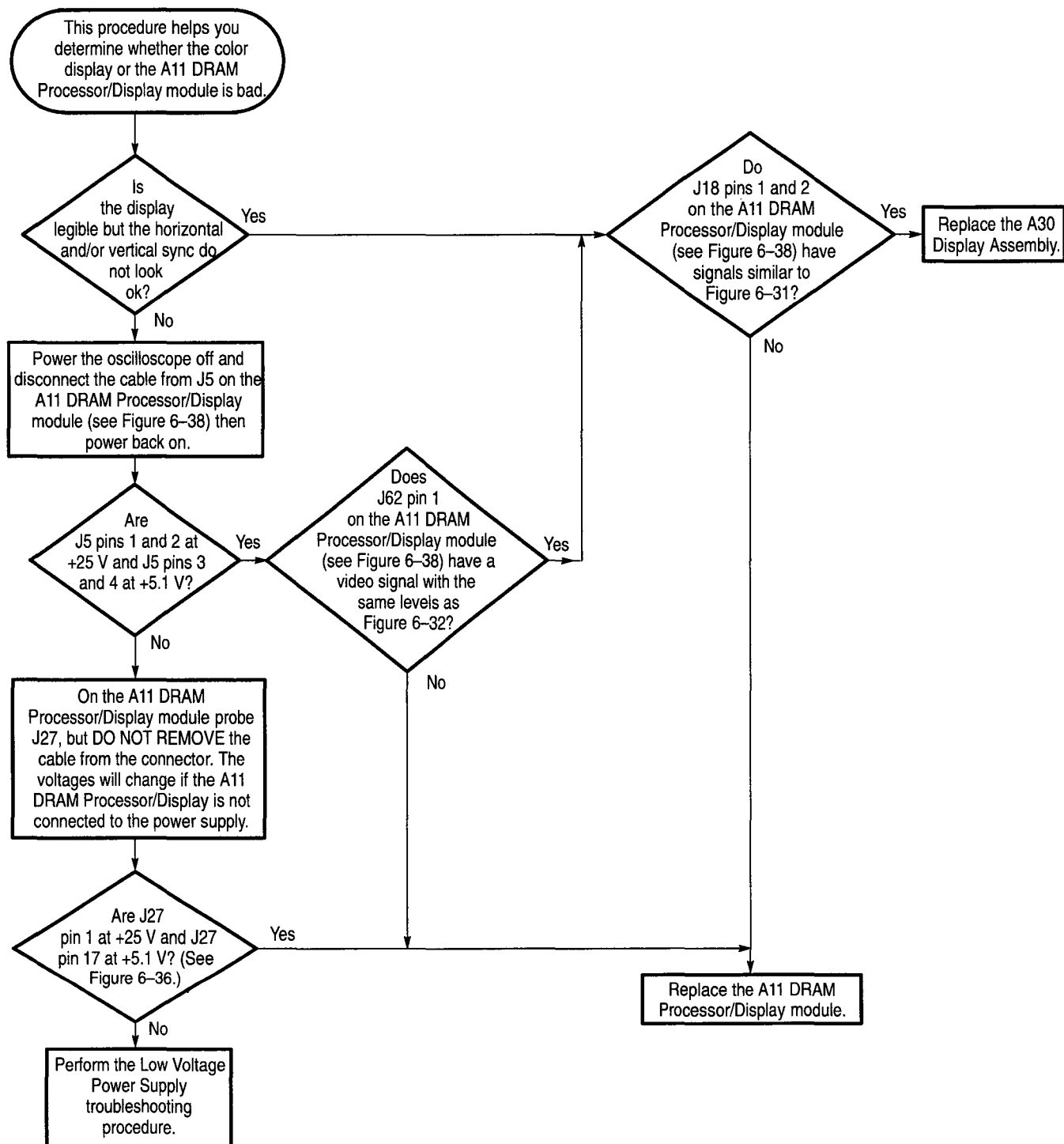

Figure 6-30: Color Display Troubleshooting Procedure

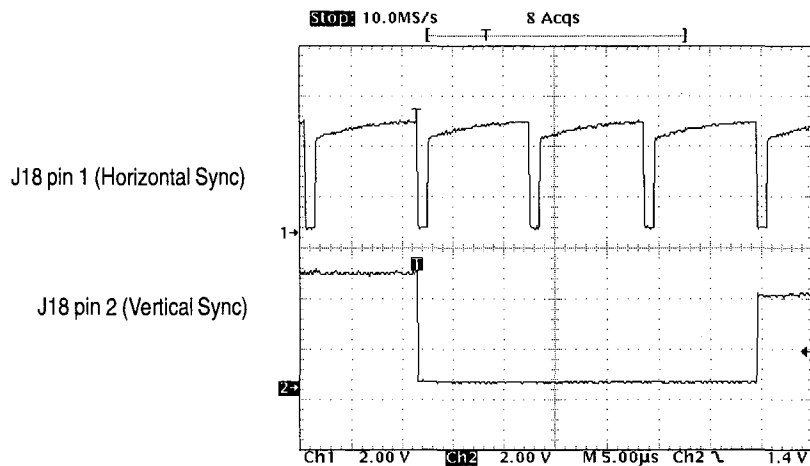

Figure 6-31: Horizontal and Vertical Sync Signals – Color Display

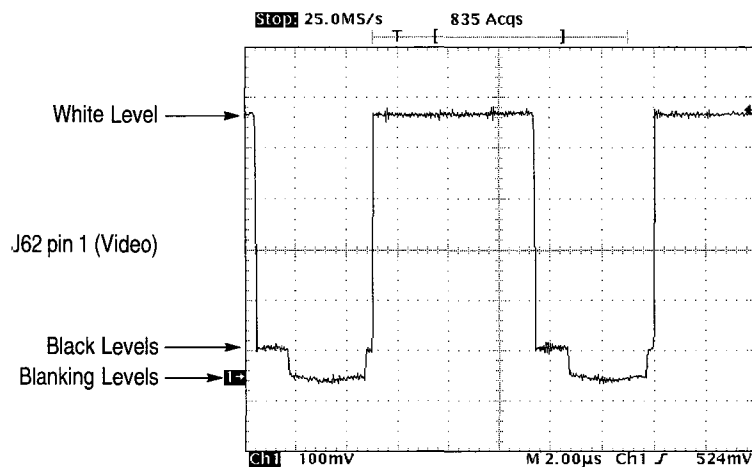

Figure 6-32: A Video Signal with White, Black, and Blanking Levels – Color Display

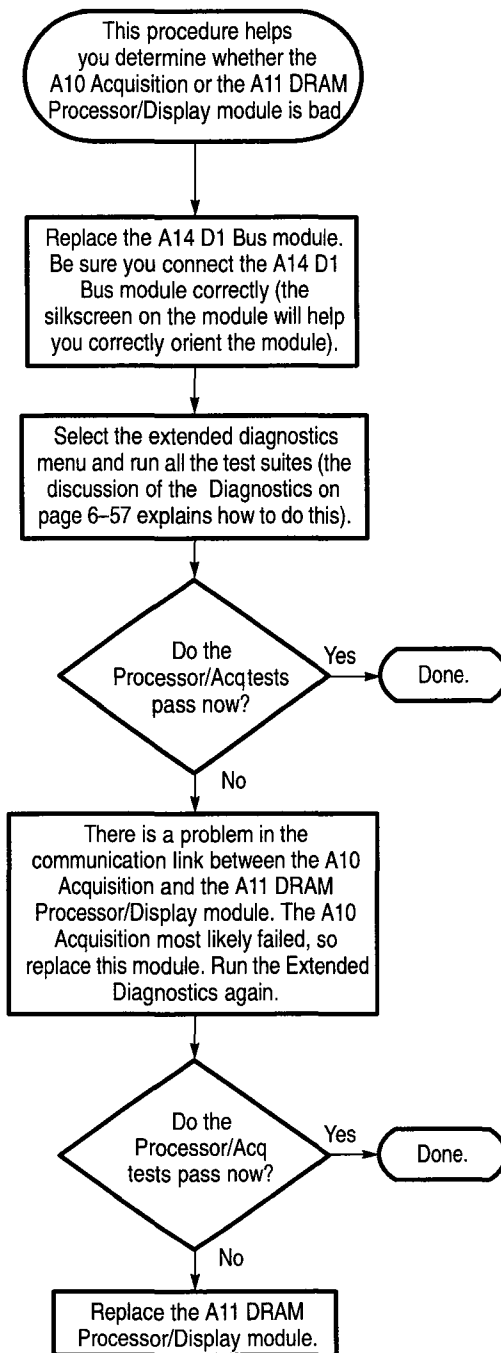

Figure 6-33: Processor/Acquisition Troubleshooting Procedure

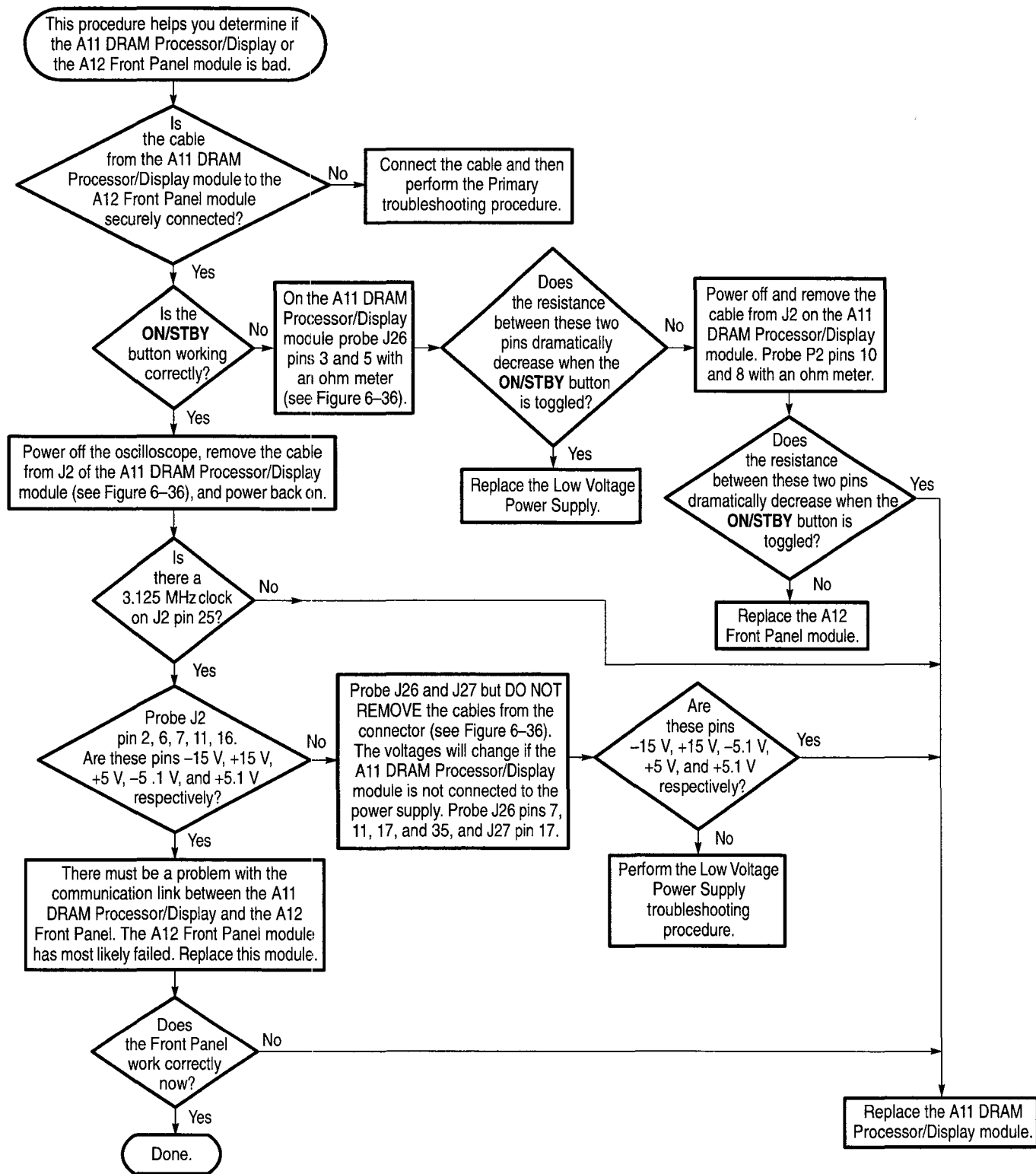

Figure 6-34: Processor/Front Panel Troubleshooting Procedure

Troubleshooting

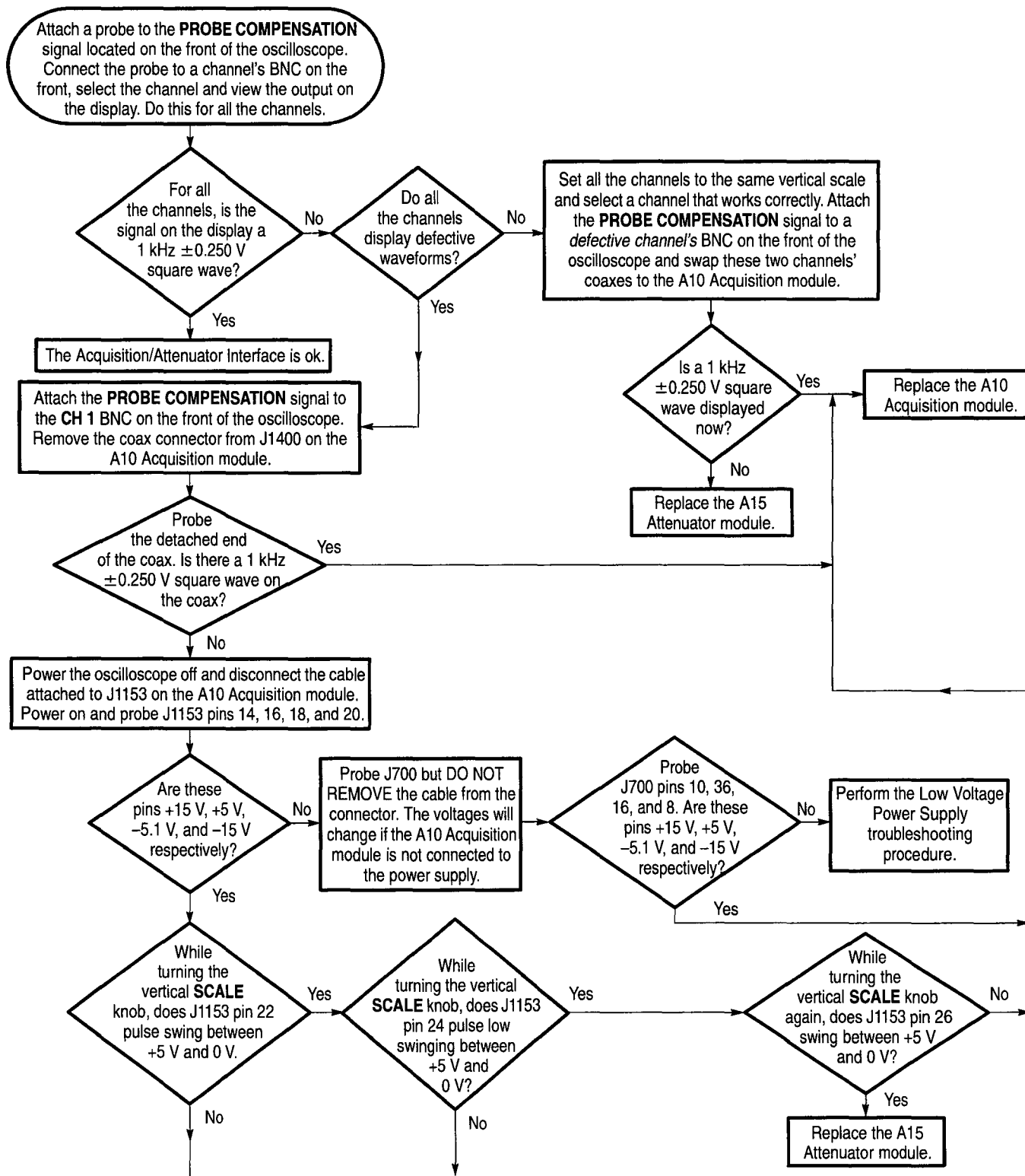

Figure 6-35: Attenuator/Acquisition Troubleshooting Procedure



CAUTION. *Only probe points specified in the procedures. You can cause catastrophic damage if you attempt to probe other points.*

Troubleshooting

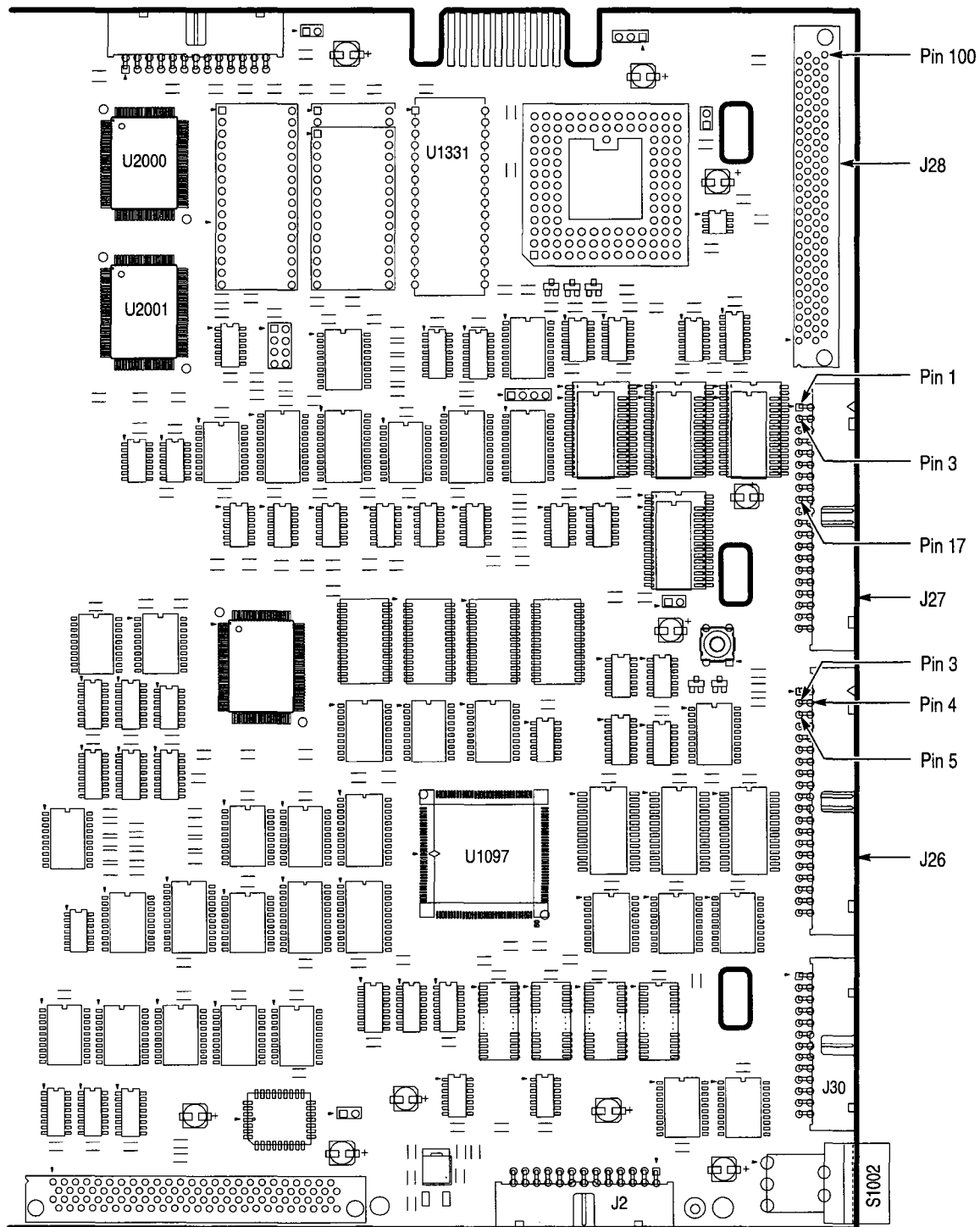

Figure 6-36: A11 DRAM Processor/Display Module (View of Right Side)

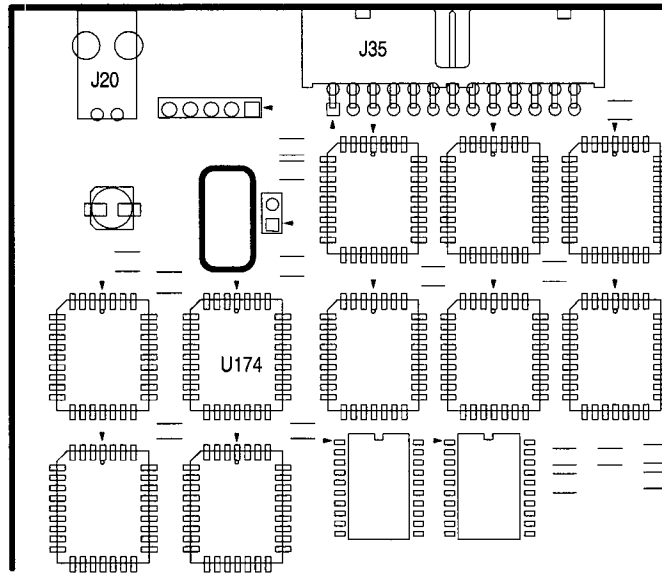

Figure 6-37: A11 DRAM Processor/Display Module (View of Upper Left Corner)

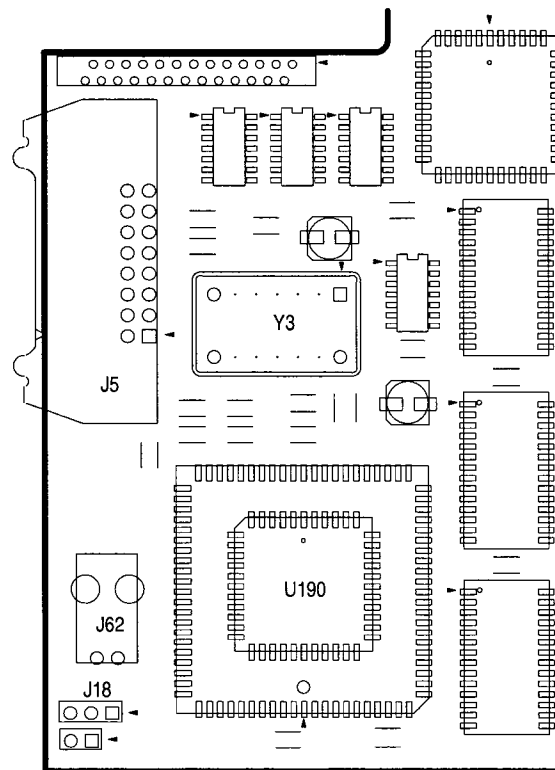

Figure 6-38: A11 DRAM Processor/Display Module (View of Lower Left Corner)

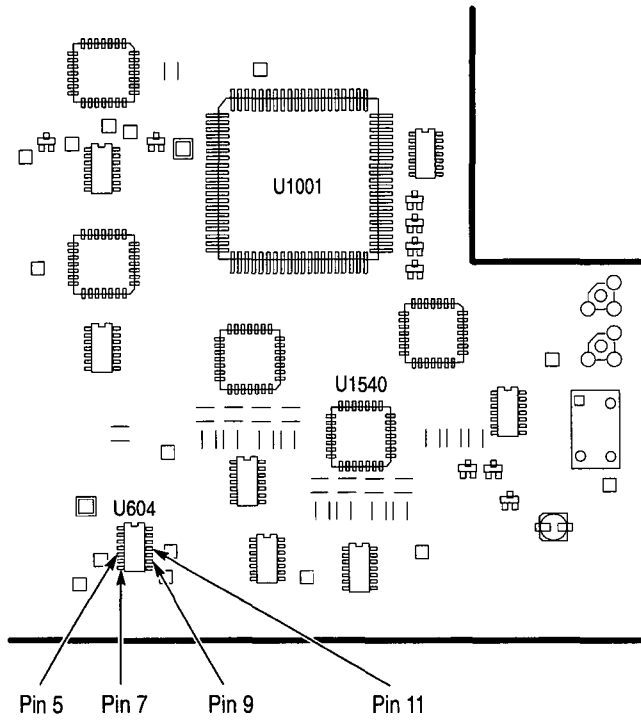

Figure 6-39: A10 Acquisition Module (View of Lower Right Corner)

Options and Accessories

This section describes the various options as well as the standard and optional accessories that are available for the TDS 684A and 744 Oscilloscope.

Options

Tektronix will ship the options shown in Table 7-1:

Table 7-1: Options

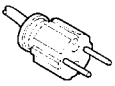
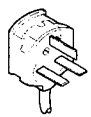
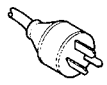
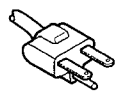
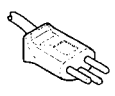
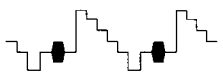
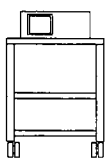
	Option #	Label	Description
	A1	Universal European power cord	220 V, 50 Hz power cord
	A2	UK power cord	240 V, 50 Hz power cord
	A3	Australian power cord	240 V, 50 Hz power cord
	A4	North American power cord	240 V, 60 Hz power cord
	A5	Switzerland power cord	220 V, 50 Hz power cord
	05	Video trigger	Oscilloscope comes with tools for investigating events that occur when a video signal generates a horizontal or vertical sync pulse. It allows investigation of a range of NTSC, PAL, SECAM, and high definition TV signals.
	1K	Scope cart	K420 scope cart. This cart can help transport the oscilloscope around many lab environments.

Options and Accessories

Table 7-1: Options (Cont.)



	Option #	Label	Description
	1M (TDS 744)	130,000 record length (TDS 744)	Extend TDS 744 record length from 50,000 standard to 130,000 samples.
	1R	Rackmount	Oscilloscope comes configured for installation in a 19 inch wide instrument rack. For later field conversions, order kit # 016-1236-00.
	23 (TDS 744)	Two active probes	Add two 1 GHz P6245 active probes
	24 on TDS 744 or 26 on TDS 684A	Four passive probes	Add four P6139 passive probes
	24 on TDS 684A or 26 on TDS 744	Four active probes	Add four 1 GHz P6245 active probes
	2P	Color printer	Tektronix Phaser 200e, 300 dpi, thermal transfer, color printer. It handles letter or A4 size Tektronix thermal paper and transparencies. It can handle laser copy (plain) paper with the ColorCoat Transfer roll.

Table 7-1: Options (Cont.)

	Option #	Label	Description
	95	Calibration Data Report	
	96	Calibration Certificate	Certificate of Calibration which states this instrument meets or exceeds all warranted specifications and has been calibrated using standards and instruments whose accuracies are traceable to the National Institute of Standards and Technology, an accepted value of a natural physical constant, or a ratio calibration technique. The calibration is in compliance with US MIL-STD-45662A. This option includes a test data report for the oscilloscope.

Standard Accessories

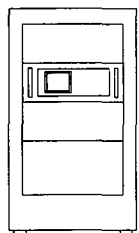
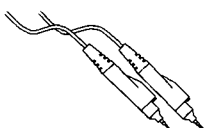
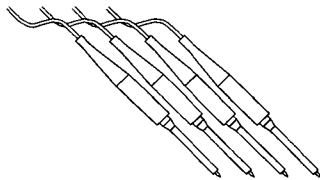
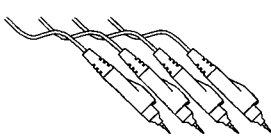
The oscilloscope comes standard with the accessories listed in Table 7-2.

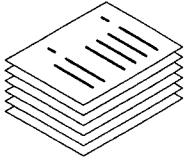
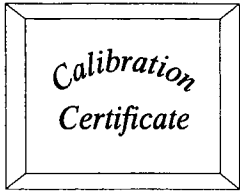
Table 7-2: Standard Accessories

Accessory	Part Number
User Manual	070-8991-xx
Programmer Manual	070-8709-xx
Reference	070-8999-xx
Performance Verification	070-8990-xx
TDS 744: Four P6139A 10X, 500 MHz Passive probes	P6139A
Front Cover	200-3696-00
U.S. Power Cord	161-0230-01

Optional Accessories

You can also order the optional accessories listed in Table 7-3.

Table 7-3: Optional Accessories

Accessory	Part Number
Service Manual	070-8992-xx
Plotter (GPIB and Centronics Standard)	HC100
Oscilloscope Cart	K420
Rack Mount Kit (for field conversion)	016-1236-00
Oscilloscope Camera	C9
Oscilloscope Camera Adapter	016-1154-00
Soft-Sided Carrying Case	016-0909-01
Transit Case	016-1135-00
GPIB Cable (1 meter)	012-0991-01
GPIB Cable (2 meter)	012-0991-00
Centronics Cable	012-1250-00

Accessory Probes

The following optional accessory probes are recommended for use with your oscilloscope:

- P6245 Active, high speed digital voltage probe. FET. DC to 1 GHz. 50 Ω input.
- P6101B 1X, 15 MHz, Passive probe.
- P6156 10X, 3.5 GHz, Passive, low capacitance, (low impedance Z_O) probe. Provides 100X, when ordered with Option 25.
- P6139A 10X, 500 MHz Passive probe.
- P6009 Passive, high voltage probe, 100X, 1500 VDC + Peak AC.
- P6015A Passive high voltage probe, 1000X, 20 kVDC + Peak AC (40 kV peak for less than 100 ms).
- P6217 Active, high speed digital voltage probe. FET. DC to 4 GHz. DC offset. 50 Ω input. Use with 1103 TekProbe Power Supply for offset control.
- P6204 Active, high speed digital voltage probe. FET. DC to 1 GHz. DC offset. 50 Ω input. Use with 1103 TekProbe Power Supply for offset control.
- P6563AS Passive, SMD probe, 20X, 500 MHz

- P6046 Active, differential probe, 1X/10X, DC to 100 MHz, 50 Ω input.
- AM 503S — DC/AC Current probe system, AC/DC. Uses A6302 Current Probe.
- AM 503S Option 03: DC/AC Current probe system, AC/DC. Uses A6303 Current Probe.
- P6021 AC Current probe. 120 Hz to 60 MHz.
- P6022 AC Current probe. 935 kHz to 120 MHz.
- CT-1 Current probe — designed for permanent or semi-permanent in-circuit installation. 25 kHz to 1 GHz, 50 Ω input.
- CT-2 Current probe — designed for permanent or semi-permanent in-circuit installation. 1.2 kHz to 200 MHz, 50 Ω input.
- CT-4 Current Transformer — for use with the AM 503S (A6302) and P6021. Peak pulse 1 kA. 0.5 Hz to 20 MHz with AM 503S (A6302).
- P6701A Opto-Electronic Converter, 500 to 950 nm, DC to 850 MHz, 1 V/mW.
- P6703A Opto-Electronic Converter, 1100 to 1700 nm, DC to 1 GHz, 1 V/mW.
- P6711 Opto-Electronic Converter, 500 to 950 nm, DC to 250 MHz, 5 V/mW.
- P6713 Opto-Electronic Converter, 1100 to 1700 nm, DC to 300 MHz, 5 V/mW.

Accessory Software

The optional accessories listed in Table 7–4 are Tektronix software products recommended for use with your oscilloscope:

Table 7–4: Accessory Software

Software	Part Number
Wavewriter: AWG and waveform creation	S3FT400
LabWindows	S3FG910

Warranty Information

Check for the full warranty statements for this product and the products listed above on the first page after the title page of each product manual.

This section describes the various options as well as the standard and optional accessories that are available for the TDS 684A and 744 Oscilloscope.

Service Assurance

Tektronix offers the following services that you can purchase any time during the warranty period of this product:

- *REPXXXX* provides one year of post-warranty repair support. It is available in one year increments up to three years.
- *CALXXXX* provides one year of calibration support. It is available in one year increments up to five years.



Electrical Parts List

The modules that make up this instrument are often a combination of mechanical and electrical subparts. Therefore, all replaceable modules are listed in Section 10, *Mechanical Parts List*. Refer to that section for part numbers when using this manual.

Electrical Parts List

Diagrams

This contains the block diagram and the interconnection diagram for the TDS 684A and 744 Digitizing Oscilloscopes.

Symbols

Graphic symbols and class designation letters are based on ANSI Standard Y32.2-1975. Abbreviations are based on ANSI Y1.1-1972.

Logic symbology is based on ANSI/IEEE Std 91-1984 in terms of positive logic. Logic symbols depict the logic function performed and can differ from the manufacturer's data.

The tilde (~) preceding a signal name indicates that the signal performs its intended function when in the low state.

Other standards used in the preparation of diagrams by Tektronix, Inc are:

- Tektronix Standard 062-2476 Symbols and Practices for Schematic Drafting
- ANSI Y14.159-1971 Interconnection Diagrams
- ANSI Y32.16-1975 Reference Designations for Electronic Equipment
- MIL-HDBK-63038-1A Military Standard Technical Manual Writing Handbook

Diagrams

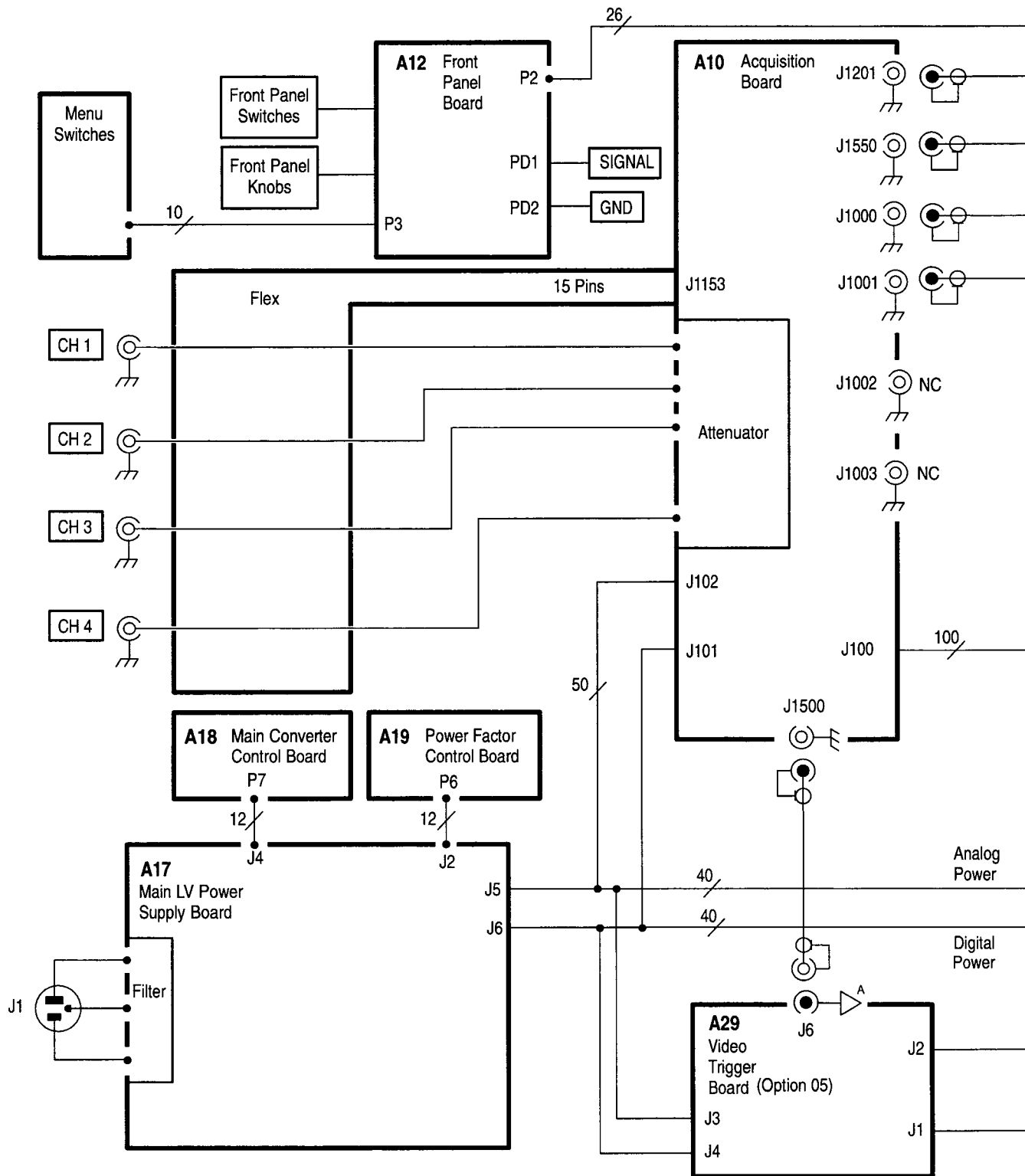

Figure 9-1: Interconnections

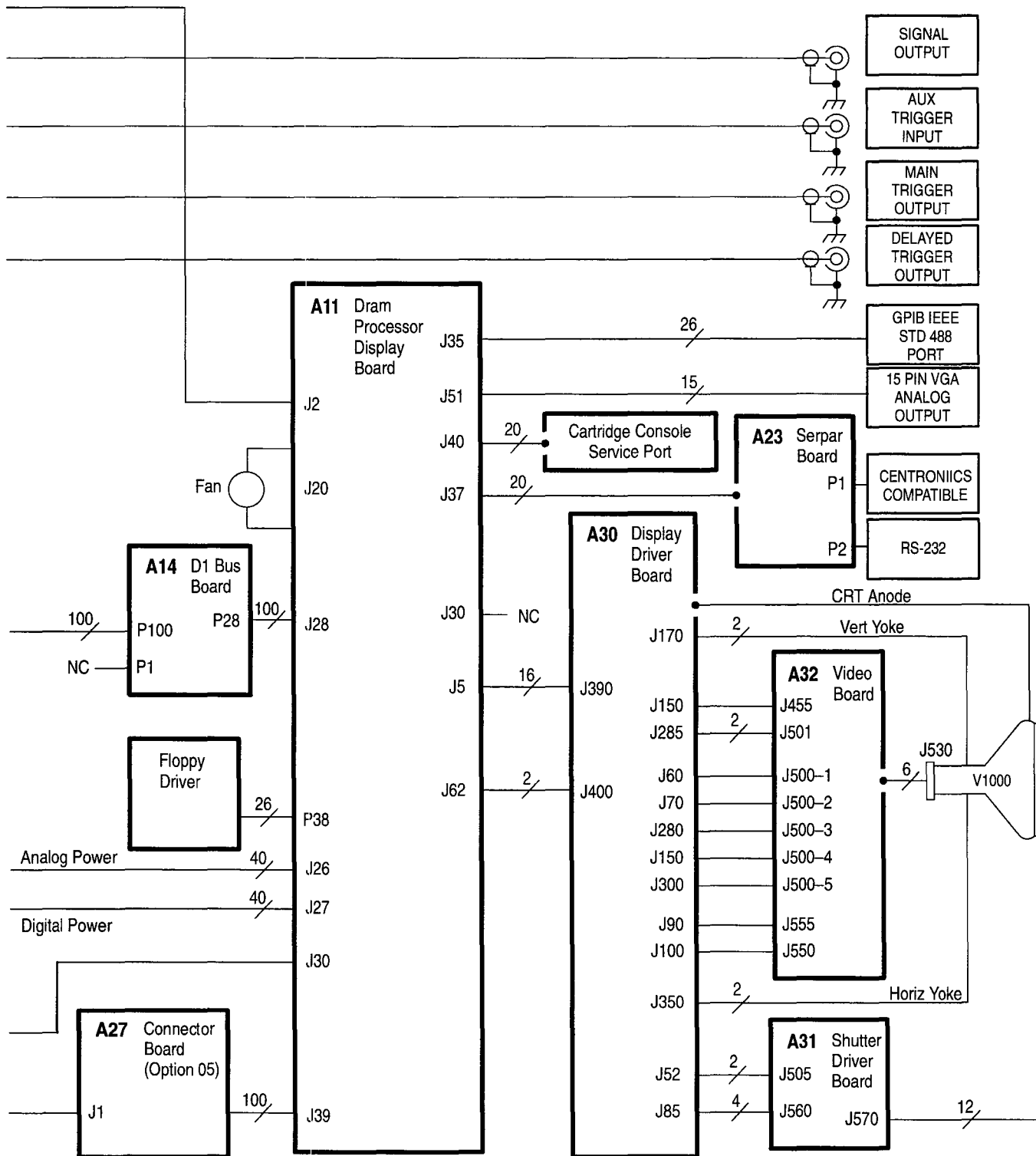

Figure 9-1: Interconnections (Cont.)

Diagrams

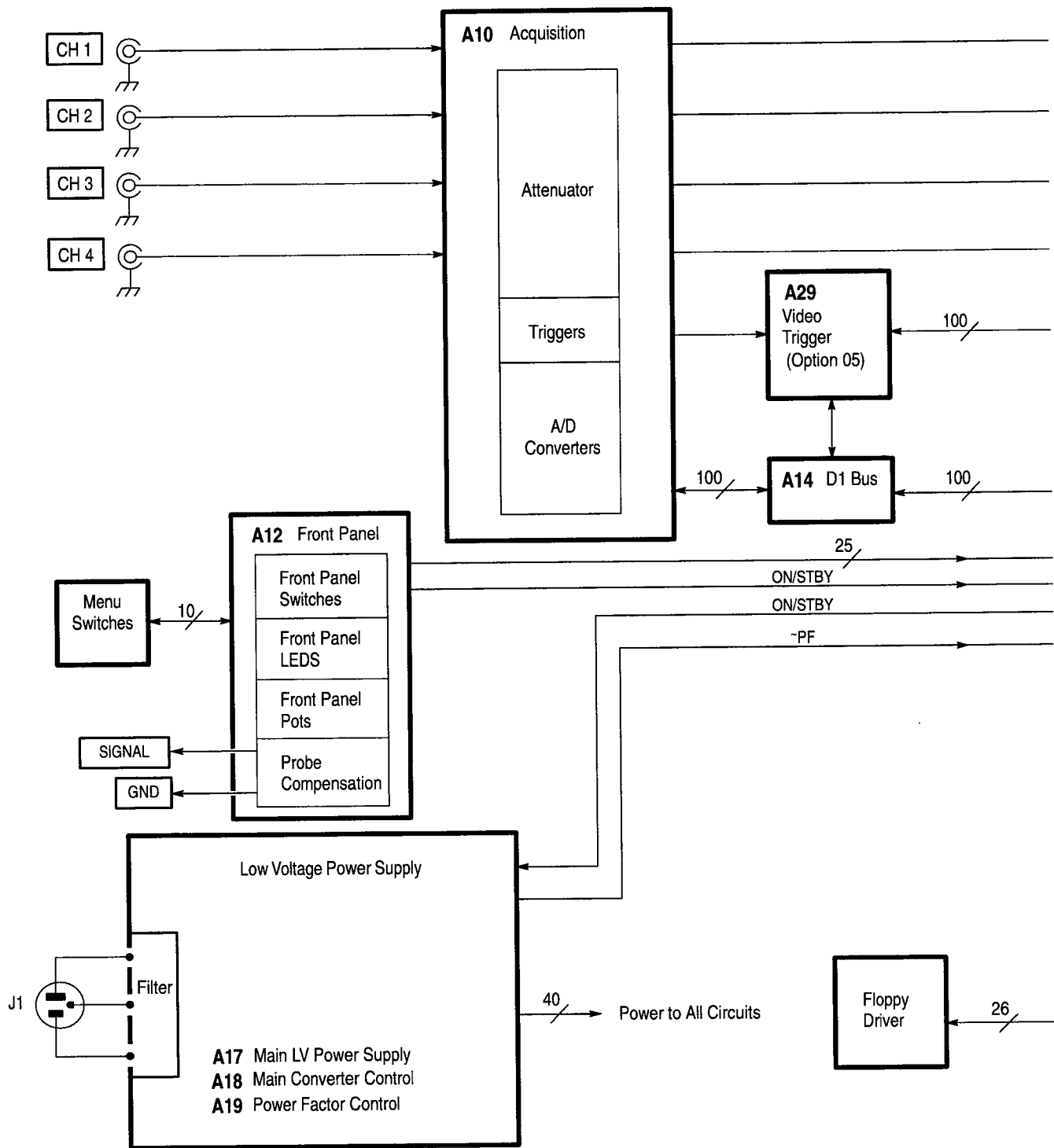

Figure 9-2: Block Diagram

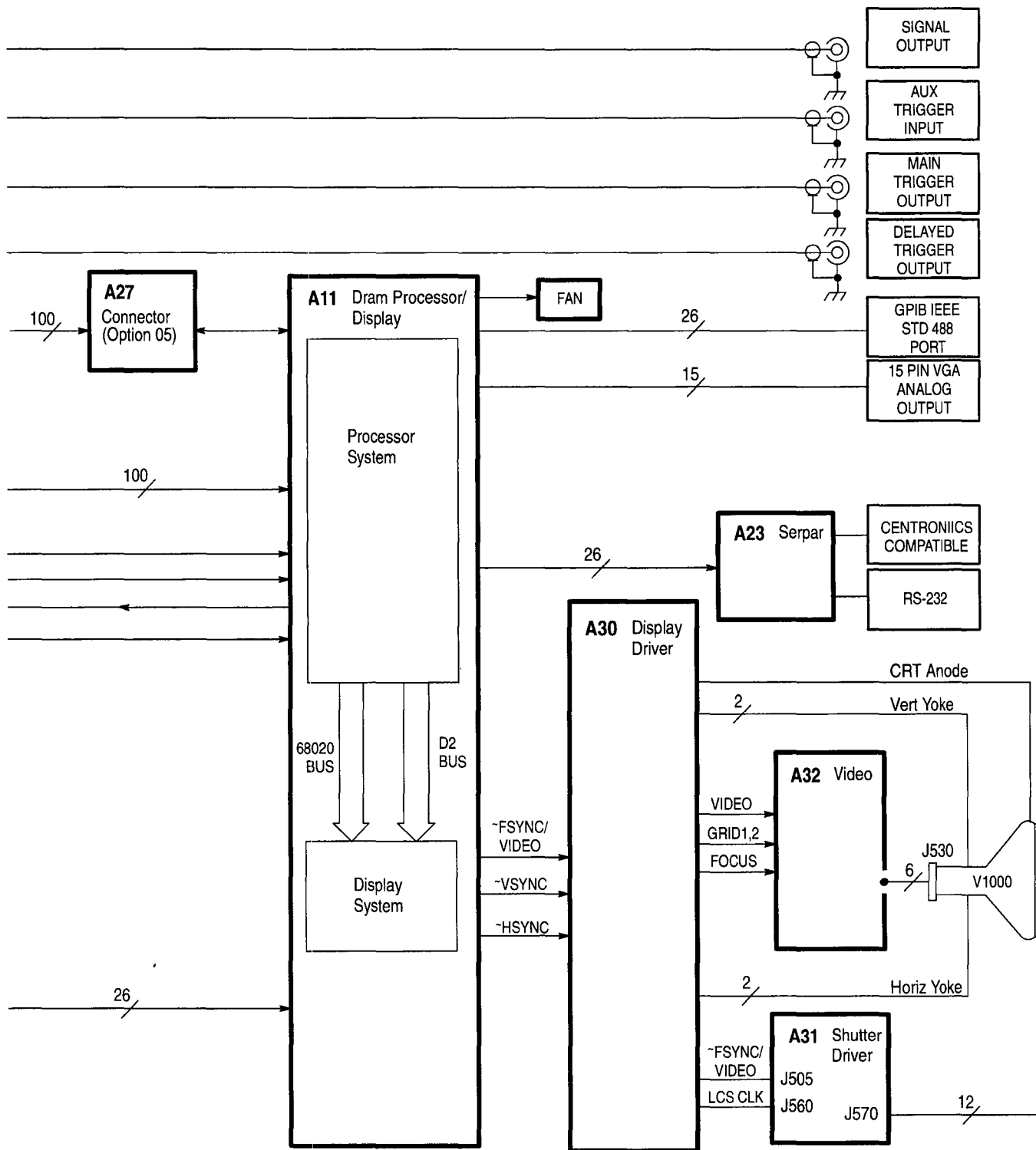

Figure 9-2: Block Diagram (Cont.)

Diagrams



Mechanical Parts List

This section contains a list of the replaceable modules for the oscilloscope. Use this list to identify and order replacement parts.

Parts Ordering Information

Replacement parts are available through your local Tektronix field office or representative.

Changes to Tektronix instruments are sometimes made to accommodate improved components as they become available and to give you the benefit of the latest circuit improvements. Therefore, when ordering parts, it is important to include the following information in your order.

- Part number
- Instrument type or model number
- Instrument serial number
- Instrument modification number, if applicable

If you order a part that has been replaced with a different or improved part, your local Tektronix field office or representative will contact you concerning any change in part number.

Change information, if any, is located at the rear of this manual.

Module Servicing

Modules can be serviced by selecting one of the following three options. Contact your local Tektronix service center or representative for repair assistance.

Module Exchange. In some cases you may exchange your module for a remanufactured module. These modules cost significantly less than new modules and meet the same factory specifications. For more information about the module exchange program, call 1-800-TEK-WIDE, extension 6630.

Module Repair and Return. You may ship your module to us for repair, after which we will return it to you.

New Modules. You may purchase replacement modules in the same way as other replacement parts.

Using the Replaceable Parts List

This section contains a list of the mechanical and/or electrical components that are replaceable for the oscilloscope. Use this list to identify and order replacement parts. The following table describes the each column in the parts list.

Parts List Column Descriptions

Column	Column Name	Description
1	Figure & Index Number	Items in this section are referenced by component number.
2	Tektronix Part Number	Use this part number when ordering replacement parts from Tektronix.
3 and 4	Serial Number	Column three indicates the serial number at which the part was first effective. Column four indicates the serial number at which the part was discontinued. No entries indicates the part is good for all serial numbers.
5	Qty	This indicates the quantity of parts used.
6	Name & Description	An item name is separated from the description by a colon (:). Because of space limitations, an item name may sometimes appear as incomplete. Use the U.S. Federal Catalog handbook H6-1 for further item name identification.
7	Mfr. Code	This indicates the code of the actual manufacturer of the part. (Code to name and address cross reference is located after this page.)
8	Mfr. Part Number	This indicates the actual manufacturer's or vendor's part number.

Abbreviations Abbreviations conform to American National Standard ANSI Y1.1-1972.

Mfr. Code to Manufacturer Cross Index The following table cross indexes codes, names, and addresses of manufacturers or vendors of components listed in the parts list.

Manufacturers Cross Index

Mfr. Code	Manufacturer	Address	City, State, Zip Code
S3109	FELLER	72 VERONICA AVE UNIT 4	SUMMERSET NJ 08873
TK0IK	MODERN METALS	UNIT A/K, 5/F GOLD KING IND. BLDG NO. 35-41 TAI LIN ROAD	KWAI-CHUNG N.T. HONG KONG
TK0488	CURRAN COIL SPRING INC	9265 SW 5TH	WILSONVILLE, OR 97070
TK0588	UNIVERSAL PRECISION PRODUCTS	1775 NW 216TH	HILLSBORO OR 97123
TK1163	POLYCAST INC	9898 SW TIGARD ST	TIGARD OR 97223
TK1465	BEAVERTON PARTS MFG CO	1800 NW 216TH AVE	HILLSBORO OR 97124-6629
TK2162	DERBY MFG	24350 STATE ROAD 23 SOUTH	SOUTH B END IN 46614-9696
TK2193	PHOTO AND SOUND	820 NW 18TH AVENUE	PORTLAND OR 97209
TK2248	WESTERN MICRO TECHNOLOGY	1800 NW 169TH PL SUITE B-300	BEAVERTON OR 97006
TK2338	ACC MATERIALS	ED SNYDER BLDG 38-302	BEAVERTON OR 97077
TK2432	UNION ELECTRIC	15/F #1, FU-SHING N. ROAD	TAIPEI, TAIWAN ROC
TK2469	UNITREK CORPORATION	3000 LEWIS & CLARK WAY SUITE #2	VANCOUVER WA 98601
TK2500	SOLECTEK ACCESSORIES CORP	6370 NANCY RIDGE DR SUITE 109	SAN DIEGO CA 92121
TK2539	ROYAL CASE CO INC	315 SOUTH MONTGOMERY PO BOX 2231	SHERMAN TX 75091-2231
TK2548	XEROX BUSINESS SERVICES DIV OF XEROX CORPORATION	14181 SW MILLIKAN WAY	BEAVERTON OR 97077
TK2561	TEKTRONIX INC CIRCUIT BOARD DIVISION	PO BOX 3000	FOREST GROVE, OR 97116
0JR05	TRIQUEST CORP	3000 LEWIS AND CLARK HWY	VANCOUVER WA 98661-2999
0J9P9	GEROME MFG CO INC	PO BOX 737 403 NORTH MAIN	NEWBERG OR 97132
0KB01	STAUFFER SUPPLY	810 SE SHERMAN	PORTLAND OR 97214
0KB05	NORTH STAR NAMEPLATE	5750 NE MOORE COURT	HILLSBORO OR 97124-6474
00779	AMP INC	2800 FULLING MILL PO BOX 3608	HARRISBURG PA 17105
07416	NELSON NAME PLATE CO	3191 CASITAS	LOS ANGELES CA 90039-2410
1DM20	PARLEX CORPORATION LAMINATED CABLE DIV	7 INDUSTRIAL WAY	SALEM, NH 03079
1GM54	ZYTEC CORPORATION	7575 MARKET PLACE DR	EDEN PRAIRIE MN 55344-3637
1JJ96	KAM ELECTRIC CO	11866 SLATER AVE NE	KIRKLAND WA 98034
2W733	COOPER INDUSTRIES INC BELDEN DIVISION	2200 US HIGHWAY 27 SOUTH PO BOX 1980	RICHMOND IN 47375-0010
22526	BERG ELECTRONICS INC (DUPONT)	857 OLD TRAIL RD	ETTERS PA 17319
24931	SPECIALTY CONNECTOR CO INC	2100 EARLYWOOD DR PO BOX 547	FRANKLIN IN 46131

Mechanical Parts List

Manufacturers Cross Index (Cont.)

Mfr. Code	Manufacturer	Address	City, State, Zip Code
30817	INSTRUMENT SPECIALTIES CO INC	EXIT 53 RT 80 BOX A	DELAWARE WATER GAP PA 18327
34416	PARSONS MFG CORP	1055 OBRIAN DR	MENLO PARK CA 94025-1408
5Y400	TRIAx METAL PRODUCTS INC DIV OF BEAVERTON PARTS MFG CO	1800 NW 216TH AVE	HILLSBORO OR 97124-6629
53387	3M COMPANY ELECTRONIC PRODUCTS DIV	3M AUSTIN CENTER	AUSTIN TX 78769-2963
61857	SAN-0 INDUSTRIAL CORP	91-3 COLIN DRIVE	HOLBROOK NY 11741
61935	SCHURTER INC	1016 CLEGG COURT	PETALUMA CA 94952-1152
75915	LITTELFUSE TRACOR INC SUB OF TRACOR INC	800 E NORTHWEST HWY	DES PLAINES IL 60016-3049
80009	TEKTRONIX INC	14150 SW KARL BRAUN DR PO BOX 500	BEAVERTON OR 97077-0001

Replaceable Parts List

Fig. & Index Number	Tektronix Part Number	Serial No. Effective	Serial No. Discont'd	Qty	Name & Description	Mfr. Code	Mfr. Part Number
10-1-1	200-3695-02			1	COVER,REAR:REAR COSMETIC COVER	TK1163	200-3695-02
-2	161-0230-01			1	CABLE ASSY,PWR,;3,18 AWG,92 L,SVT,TAN (STANDARD ACCESSORY)	TK2432	ORDER BY DESC
-3	343-1213-00			1	CLAMP,PWR CORD:POLYIMIDE (STANDARD ACCESSORY)	TK1163	ORDER BY DESC
-4	200-2264-00			1	CAP,FUSEHOLDER:3AG FUSES (AMERICAN)	61935	FEK 031 1666
	200-2265-00			1	CAP,FUSEHOLDER:5 X 20MM FUSES (EUROPEAN)	61935	FEK 031.1663
-5	159-0013-00			1	FUSE,CARTRIDGE:3AG,6A,250V,FAST BLOW (AMERICAN)	75915	312006
	159-0210-00			1	FUSE,CARTRIDGE:5AMP,250VSLOW BLOW (EUROPEAN)	61857	ET 5 AMP
-6	650-3039-00			1	CABINET ASSY:	0J9P9	650-3039-00
-7	367-0247-01			1	HANDLE,CARRYING:11.54 L,W/CLIP	80009	367024701
-8	200-2191-00			2	CAP,RETAINER:PLASTIC	0JR05	ORDER BY DESC
-9	437-0399-01			1	CABINET,SCOPE:	80009	437039901
-10	348-1110-02			4	FOOT,CABINET:	80009	348111002
-11	348-1254-01			4	PAD,FOOT:TEK BLACK,SANTOPRENE	80009	348125401
-12	348-0875-00			1	FLIPSTAND,CAB.:	TK0488	ORDER BY DESC
-13	348-1109-01			2	GASKET,SHIELD:348-1109-00 CUT 45.0 L	80009	348110901
-14	200-3696-01			1	COVER,FRONT:PLASTIC (STANDARD ACCESSORY)	80009	200369601
-15	101-0142-00			1	TRIM,DECORATIVE:FRONT	TK1163	ORDER BY DESC
-16	334-8581-00			1	MARKER,IDENT:FRONT NOMINCLATURE (TDS684A ONLY)	0KB05	334-8581-00
	334-8788-00			1	MARKER,IDENT:0.010 POLYCARBONATE (TDS744 ONLY)	80009	334878800
-17	214-4287-00			1	ACTUATOR:ELASTOMER MAT,FRONT PANEL,RBR	TK0IK	ORDER BY DESC
-18	366-2114-00			2	KNOB:LARGE,DETENTED	TK1163	ORDER BY DESC
-19	366-2111-00			3	KNOB:SMALL,FLUTED	TK1163	ORDER BY DESC
-20	650-2927-00			1	REPLACEABLE AS:DISPLAY FRAME WITH FLEX	80009	650292700
-21	386-5954-00			1	PANEL,INPUT:PLASTIC,ATTENUATOR	80009	386595400
-22	614-0914-02			1	FRONT PANEL ASSY: (A12, EXCHANGE ITEM)	80009	614091402
-23	366-2170-00			1	KNOB:DIMPLED GPK,1.7 DIA	TK1163	ORDER BY DESC

Mechanical Parts List

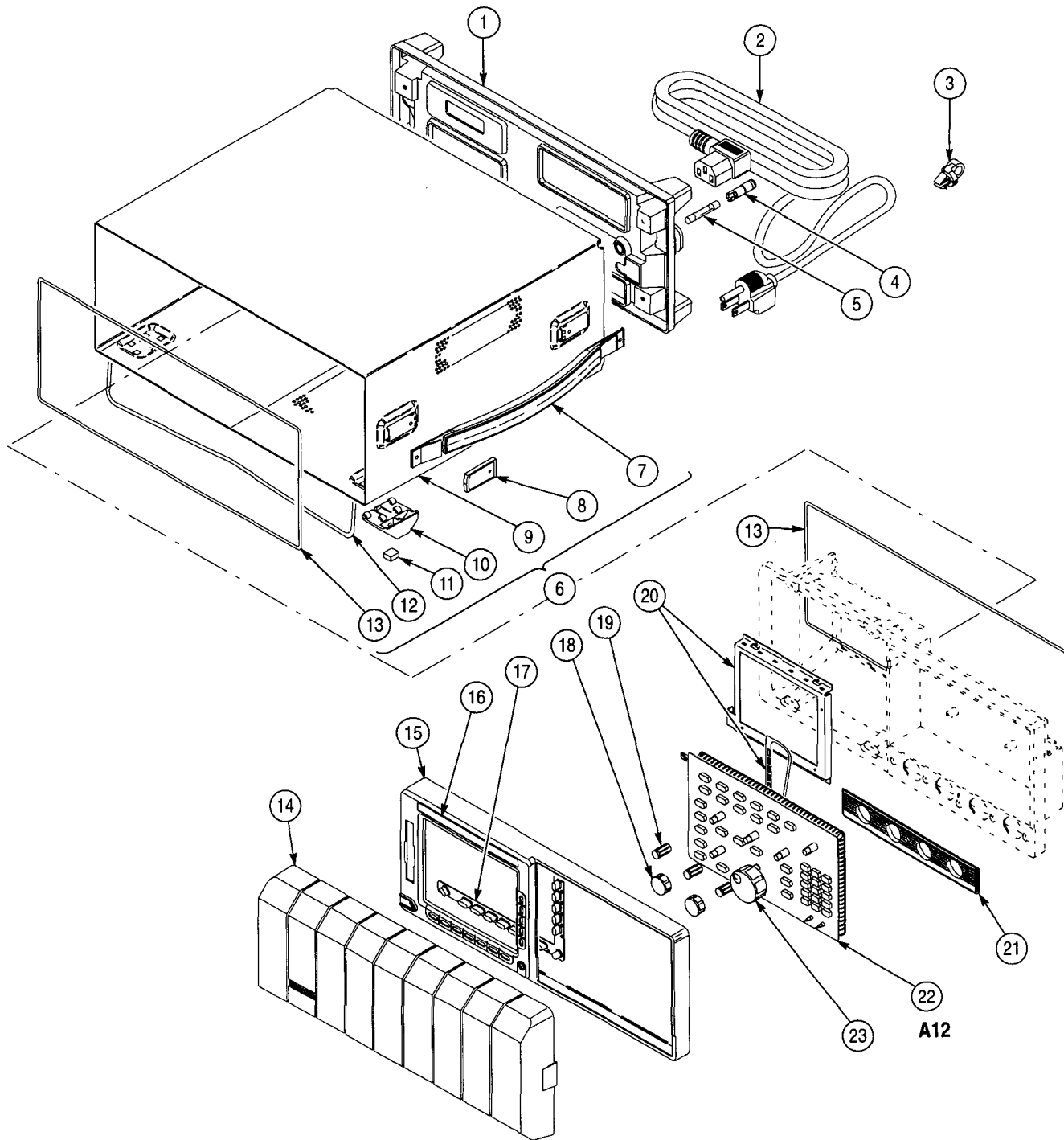

Figure 10-1: External Modules

Replaceable Parts List

Fig. & Index Number	Tektronix Part Number	Serial No. Effective	Serial No. Disc't'd	Qty	Name & Description	Mfr. Code	Mfr. Part Number
10-2-1	212-0189-00			6	SCR,ASSEM WSHR:8-32 X 0.500,PNH,STL	0KB01	ORDER BY DESC
-2	119-4615-00			1	FAN,DC:TUBEAXIAL;ASSY,24V,6W,2800/1600 RPM	TK2469	119-4615-00
-3	671-3182-00			1	CIRCUIT BD ASSY:COLOR PROCESSOR DISPLAY (A11,EXCHANGE ITEM)	80009	671318200
-4	441-1902-01			1	CHASSIS,SCOPE:REAR	0J9P9	ORDER BY DESC
-5	334-7966-02			1	MARKER,IDENT:MKD W/CONNECTOR IDENT	07416	334-7966-02
-6	131-1315-01			4	CONN,RF JACK:BNC/PNL,;50 OHM,FEMALE	24931	28JR306-1
-7	671-2437-00			1	CIRCUIT BD ASSY:RS232/CENTRONIC	80009	671243700
-8	407-3825-00			2	BRACKET,CKT BD:PLASTIC,REAR	TK1163	ORDER BY DESC
-9	386-6182-00			1	PLATE,REAR:ALUMINUM,RS232/CENTRONIC	0J9P9	386-6182-00
-10	131-0890-01			10	CONN,HARDWARE:DSUB,JACK SCREW	00779	205818-2
-11	348-1300-00			2	SHLD,GSKT,ELEK:3.165 L,CLIP ON	30817	0098-0564-09-03
-12	211-0730-00			6	SCR,ASSEM WSHR:6-32 X 0.375,PNH,STL,T-15	0KB01	ORDER BY DESC
-13	671-2847-00			1	CIRCUIT BD ASSY:D1 BUS (A14,OPT 05,EXCHANGE ITEM)	80009	671284700
	671-2848-00			1	CIRCUIT BD ASSY:D1 BUS (A14,EXCHANGE ITEM)	80009	671284800
-14	671-2694-00			1	CIRCUIT BOARD:ACQUISITION (A10,EXCHANGE ITEM,TDS684A ONLY)	80009	671269400
	671-3279-00			1	CKT BD ASSY:ACQUISITION (A10,EXCHANGE ITEM,TDS744 ONLY)	80009	671327900
-15	259-0101-01			1	FLEX CIRCUIT:TEK PROBE INTERFACE	TK2561	259-0101-01
-16	343-0088-00			2	CLAMP,CABLE:0.062 DIA,PLASTIC	80009	343008800
-17	407-3878-00			6	BRACKET,CKT BD:PLASTIC	TK1163	ORDER BY DESC
-18	407-3877-00			2	BRACKET,CKT BD:PLASTIC	TK1163	ORDER BY DESC
-19	441-1901-00			1	CHASSIS,SCOPE:TOP	0J9P9	ORDER BY DESC

Mechanical Parts List

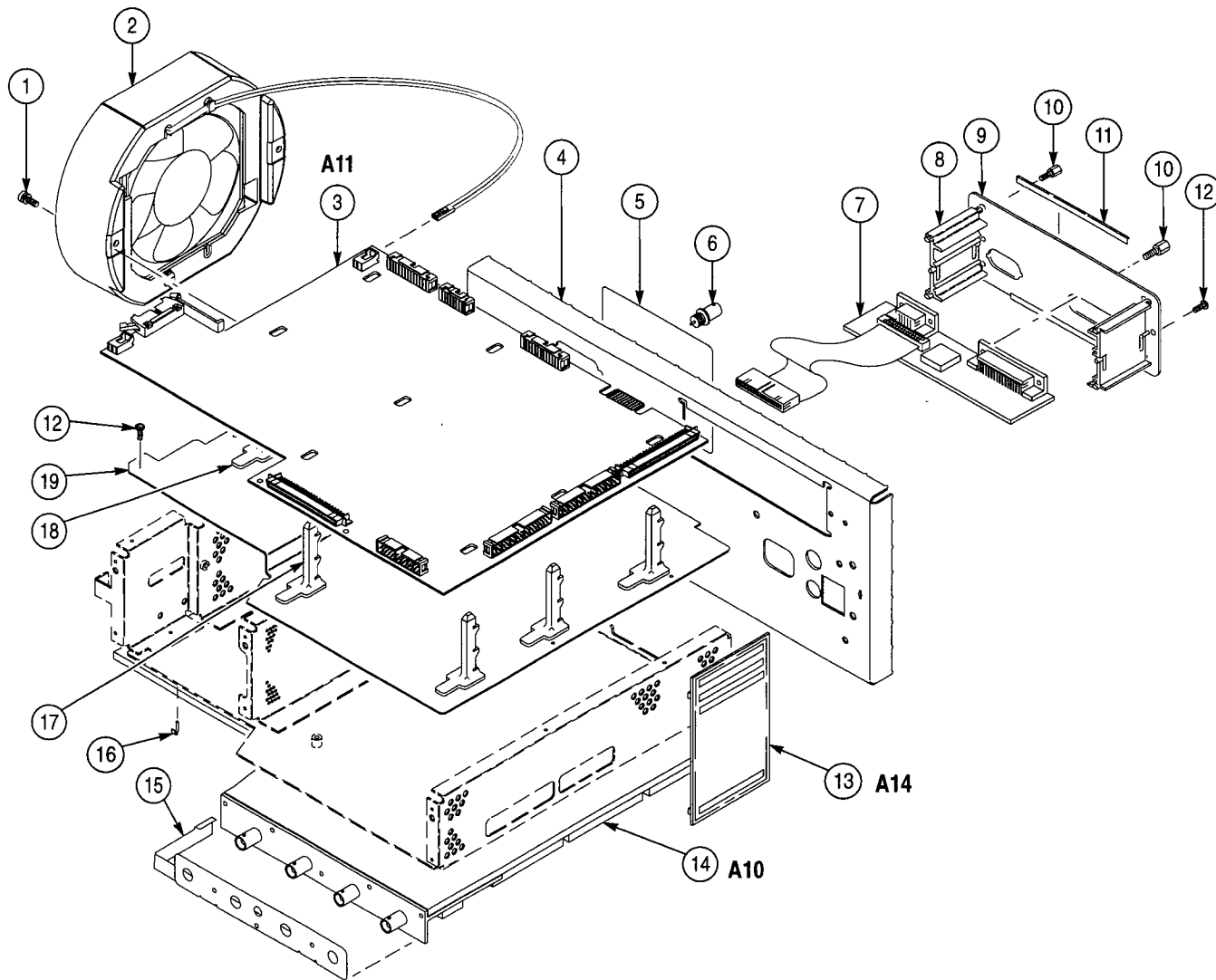

Figure 10-2: Outer-Chassis Modules

Replaceable Parts List

Fig. & Index Number	Tektronix Part Number	Serial No. Effective	Serial No. Discont'd	Qty	Name & Description	Mfr. Code	Mfr. Part Number
10-3-1	640-0077-03			1	DISPLAY MODULE:TDS FAMILY FULL COLOR	80009	640007703
-2	348-1300-00			2	SHLD,GSKT,ELEK:3.165 L,CLIP ON	30817	0098-0564-09-03
-3	620-0063-01			1	POWER SUPPLY:400W;5V 12A,5.1V 22A,15V 1.5A (A16,EXCHANGE ITEM,TDS684A ONLY)	1GM54	620-0063-01
	620-0063-02			1	POWER SUPPLY:400W;5V 12A,5.1V 22A,15V 1,5A (A16,EXCHANGE ITEM,TDS744 ONLY)	80009	620006302
-4	441-2043-00			1	CHASSIS,SCOPE:MAIN,0.05 ALUMINUM	0J9P9	441-2043-00
-5	386-5871-01			1	SUBPANEL,FRONT:FINISHED,ALUMINUM	5Y400	386-5871-01

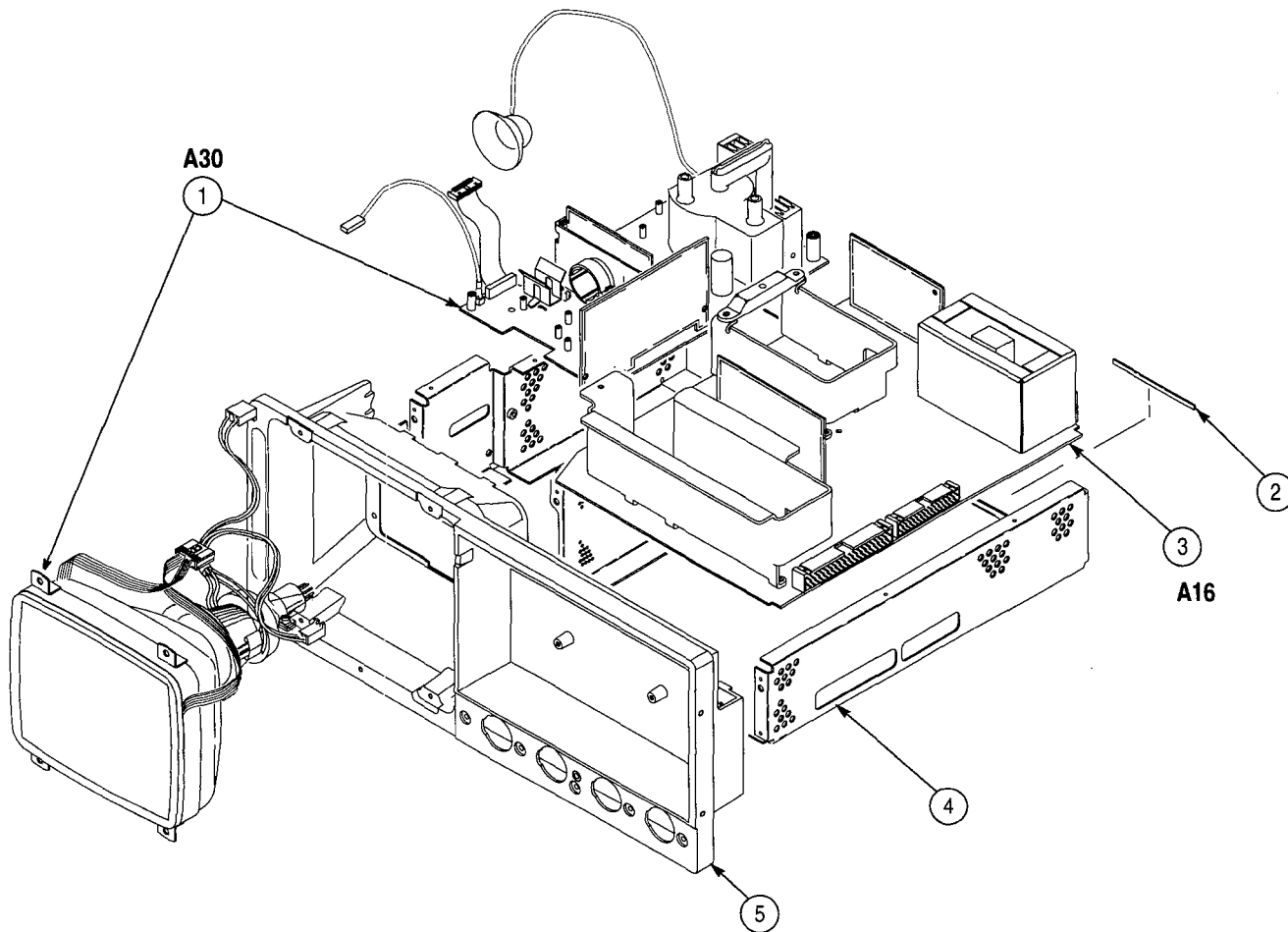

Figure 10-3: Inner-Chassis Modules

Mechanical Parts List

Replaceable Parts List

Fig. & Index Number	Tektronix Part Number	Serial No. Effective	Serial No. Discont'd	Qty	Name & Description	Mfr. Code	Mfr. Part Number
10-4-1	174-2031-00			4	CABLE ASSY,RF:50 OHM COAX,6.5 L,W/BBLUE JKT (A10J1000 MAIN TO TRIGGER OUTPUT) (A10J1001 TO DELAYED TRIGGER OUTPUT)	TK2338	174-2031-00

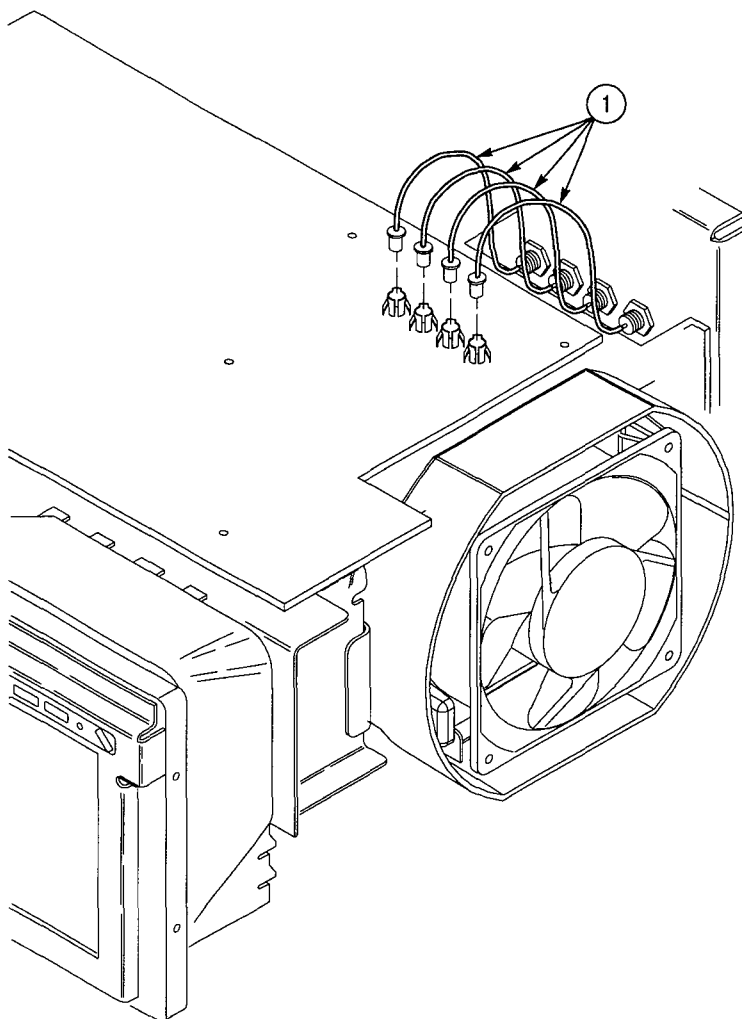

Figure 10-4: Cables, Bottom View

Replaceable Parts List

Fig. & Index Number	Tektronix Part Number	Serial No. Effective	Serial No. Discont'd	Qty	Name & Description	Mfr. Code	Mfr. Part Number
10-5-1	174-1525-00			1	CA ASSY,SP,ELEC:2 X 8-13,28 AWG	TK2469	ORDER BY DESC
-2	174-1524-00			1	CA ASSY SP:RIBBON,GPIB;IDC,24,28 AWG	TK2469	ORDER BY DESC
	129-1439-00			2	SPACER,POST:0.17 L,4-40 BRS,0.25 RND (USE WITH 174-1524-XX ONLY)	TK0588	ORDER BY DESC
-3	174-2975-00			1	CA ASSY,SP:RIBBON,;CPR,16,28 AWG,4.0 L	TK2469	ORDER BY DESC
	131-0890-01			2	CONN,HARDWARE:DSUB,JACK SCREW	00779	205818-2
-4	346-0266-00			1	STRAP,CABLE:PLASTIC	0KB05	346-0266-00
-5	174-3053-00			1	CA ASSY,SP,ELEC:50,28 AWG,5.85 L,FLAT (VGA CABLE)	53387	174-3053-00
-6	174-3052-00			2	CA ASSY,SP,ELEC:50,28 AWG,5.85 L,FLAT	53387	174-3052-00
-7	174-1728-00			1	CA ASSY,SP:RIBBON,;IDC,26,28 AWG,6.0 L	53387	ORDER BY DESC

Mechanical Parts List

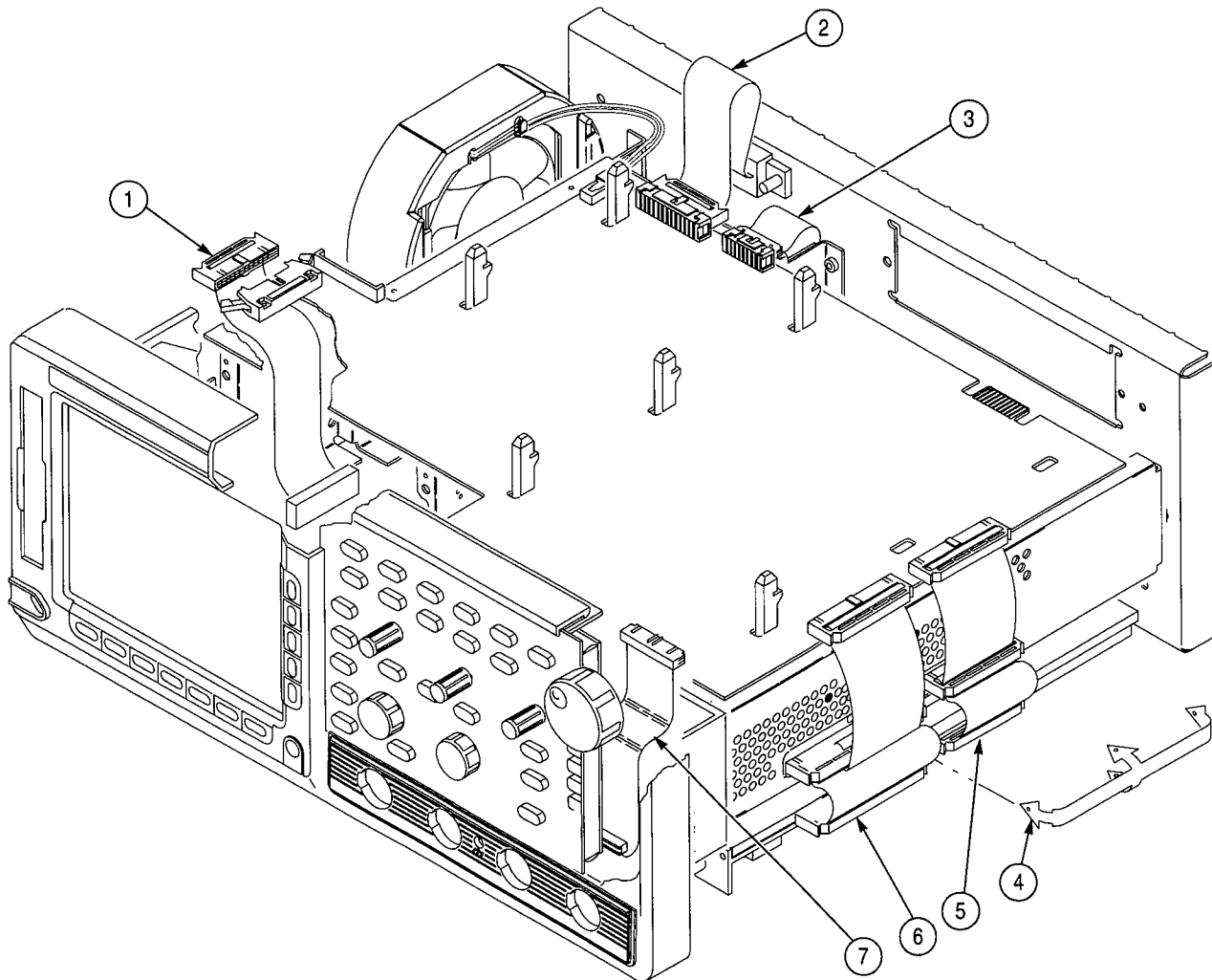

Figure 10-5: Cables, Top View

Replaceable Parts List

Fig. & Index Number	Tektronix Part Number	Serial No. Effective	Serial No. Discont'd	Qty	Name & Description	Mfr. Code	Mfr. Part Number
10-6-1	119-4547-00			1	DISK DRIVE:FLOPPY,3.5 INCH;2MB,0.5 INH DSDD	TK2248	119-4547-00
-2	211-0840-00			2	SCREW,MACHINE:M2.6 X 0.45MM PITCH X 4.0 L	0KB01	.26C4MXPY
-3	211-0730-00			2	SCR,ASSEM WSHR:6-32 X 0.375,PNH,STL,T-15	0KB01	ORDER BY DESC
-4	174-2964-00			1	WIRE,ELECTRICAL:FLAT FLEX,JUMPER	1DM20	1.00MM-26-7-B
	276-0849-00			1	CORE,EM:EMI SUPPRESS,RBN CABLE	1JJ96	BFS 33.5 X 8
-5	407-4230-00			1	BRKT,DISK DRIVE:ALUMINUM	0J9P9	407-4230-00
-6	337-3935-00			1	SHLD,DISK DRIVE:	0JR05	337-3935-00

Mechanical Parts List

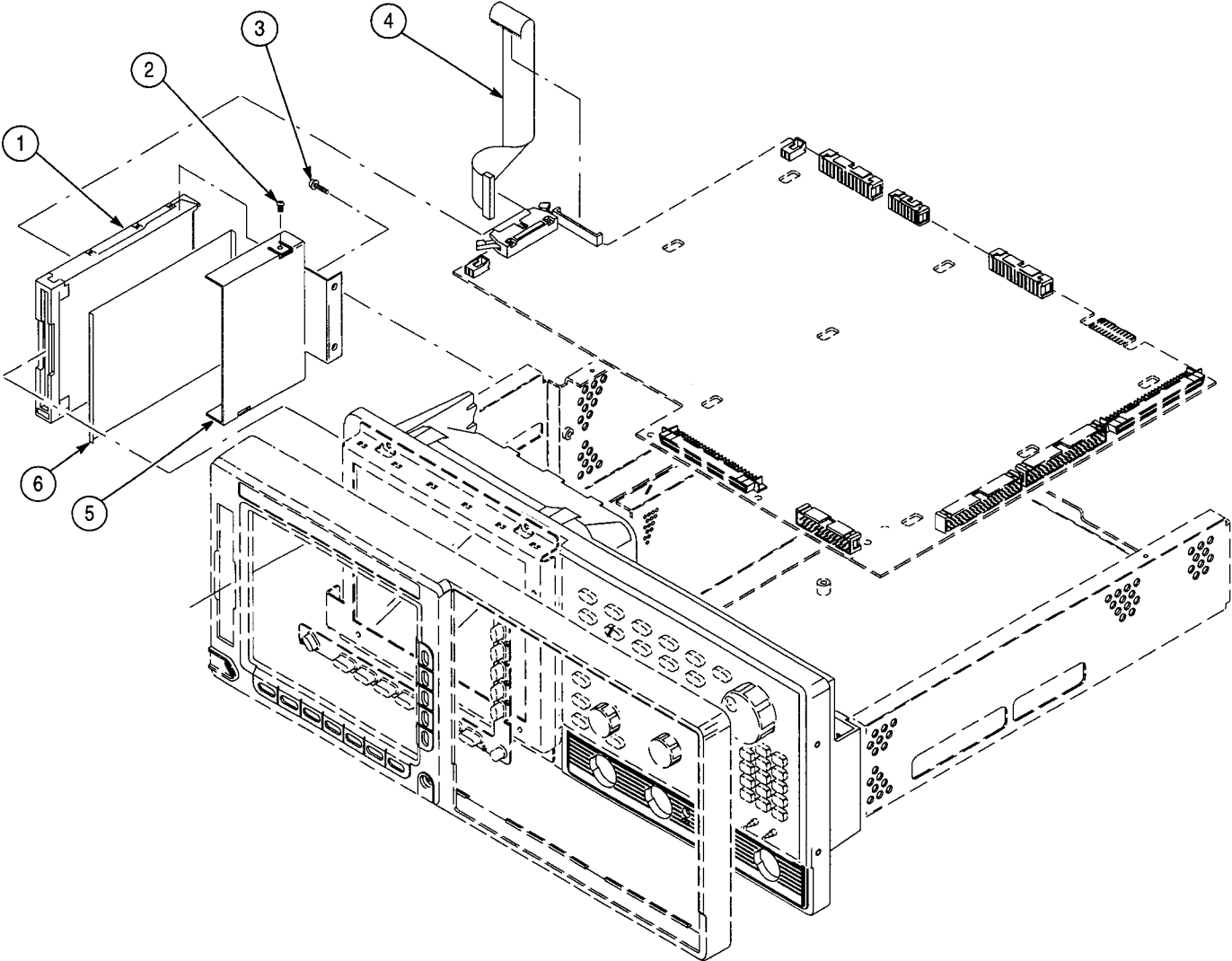

Figure 10-6: Floppy Disk

Replaceable Parts List

Fig. & Index Number	Tektronix Part Number	Serial No. Effective	Serial No. Discont'd	Qty	Name & Description	Mfr. Code	Mfr. Part Number
STANDARD ACCESSORIES							
10-7-1	161-0104-05			1	CA ASSY,PWR:3,1.0MM SQ,250V/10A,2.5 M (OPTION A3 - AUSTRALIAN)	S3109	SAA/3-OD3CCFC3 X
-2	161-0104-06			1	CA ASSY,PWR:3,1.0MM SQ,250V/10A,2.5 METER (OPTION A1 - EUROPEAN)	S3109	VIIGSOPO-HO5VVF
-3	161-0104-07			1	CA ASSY,PWR:3,1.0MM SQ,240V/10A,2.5 METER (OPTION A2 - UNITED KINGDOM)	S3109	ORDER BY DESC
-4	161-0104-08			1	CA ASSY,PWR:3,18 AWG,250/10A,98 INCH L (OPTION A4 - NORTH AMERICAN)	2W733	ORDER BY DESC
-5	161-0167-00			1	CA ASSY,PWR:3,0.75MM SQ,250V/10A,2.5 METER (OPTION A5 - SWITZERLAND)	S3109	ORDER BY DESC
	-----			1	CABLE ASSY,POWER,:3,18 AWG,92 L (STANDARD CABLE - SEE FIG 10-1-2)		
	343-0170-00			1	RTNR,CA TO CA:U/W 0.25 OD CABLES (OPTIONS A1,A2,A3,A4,A5)	0JR05	ORDER BY DESC
	-----			1	CLAMP,PWER CORD:POLYIMIDE (SEE FIGURE 10-1-3)		
	070-8709-05			1	MANUAL,TECH:PRGM,TDS4XX,5XXA,6XXA,744	80009	070870905
	070-8991-01			1	MANUAL,TECH:USER,TDS684A & TDS744	80009	070899101
	070-8990-02			1	MANUAL,TECH:PERF VERIF,TDS684A & TDS744	80009	070899002
	070-8999-01			1	MANUAL,TECH:REFERENCE,TDS684A & TDS744	80009	070899901
	-----			1	COVER,FRONT:PLASTIC (SEE FIG 10-1-14)		
	016-1268-00			1	POUCH,ACCESS:	TK2539	2122

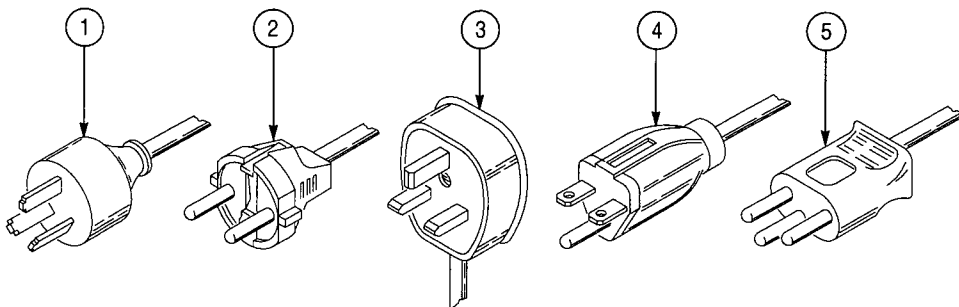

Figure 10-7: Accessories

Mechanical Parts List

Replaceable Parts List

Fig. & Index Number	Tektronix Part Number	Serial No. Effective	Serial No. Discont'd	Qty	Name & Description	Mfr. Code	Mfr. Part Number
OPTIONAL ACCESSORIES							
	003-1457-01			1	BIT,TORX DRIVER:MODIFY THE T-20	TK1465	003-1457-01
	012-0991-00			1	CABLE,INTCON:SHLD CMPST,GPIB	22526	81190-020
	012-0991-01			1	CABLE,GPIB:LOW EMI,1 METER	00779	553577-2
	012-1250-00			1	CABLE,INTCON:SHLD CMPST,PARALLEL	TK2193	CACC 3049
	012-1298-00			1	CABLE,INTCON:RS232C DB25M-DB9F SERIAL	TK2500	C294-9
	012-1388-00			1	CABLE ASSEMBLY:OSCILLOSCOPE SECURITY	80009	012138800
	016-0909-01			1	CASE,CARRYING:SOFTSIDED FOR 3002C	TK2162	0587
	016-1135-00			1	CASE,CARRYING:26 X 22 X 15,HARD TRANSFER	34416	2622RW-7T-7B
	016-1145-00			1	HOOD ASSEMBLY:TDS SERIES	80009	016114500
	016-0099-00			1	HDW KIT,ELEK EQ:RACKMOUNTING HDW	80009	016009900
	070-8992-02			1	MANUAL,TECH:SERVICE,TDS684A & TDS744	80009	070899202
	070-8432-02			1	MANUAL,TECH:INSTRUCTION,TDS FAMILY	TK2548	PER TEK P/N